

EchemLab



Apps-Xim series

AMETEK

solartron
analytical



Apps-XM series

- Smaller Footprint
- Competitively Priced
- Best In Class **XM** Accuracy

EchemLab XM is one of Solartron Analytical's Apps-XM series of **X**treme **M**easurement products that are each precisely focused on the requirements for specific applications.

These exciting new products have a much smaller footprint than most competitive units - delivering unmatched **XM** measurement performance while taking less of your restricted lab space.

Each **XM** module is individually calibrated using Solartron Analytical's unique multi-point calibration and tested to rigorous standards ensuring best accuracy.



- ±100 V polarization and compliance**
- High voltage auxiliary channels**
- Highest accuracy DC and EIS**
- Multiple AC techniques include single sine, harmonic analysis (non-linear materials), multisine for faster low frequency tests**

Apps-XM

EnergyLab XM	for battery, fuel cells, supercapacitors
EchemLab XM	for corrosion/coatings and physical electrochemistry
SolarLab XM	for solar/PV cells
Materials Lab XM	for dielectrics, insulators, and electronic materials

EchemLab XM

Xtreme Measurement

EchemLab XM is an application specific **XM** (Xtreme Measurement) product that is primarily focused on corrosion/coatings, and physical/analytical electrochemistry.

EchemLab XM includes a reference grade potentiostat and frequency response analyzer (FRA). **EchemLab XM** has a built-in 100 V high voltage amplifier which can be used for not only for compliance measurements but also for high voltage cell polarization. This is useful in many high solution resistance applications, for example in organic electrochemistry. In addition to high voltage, power boosters can also be integrated to combine high current and high voltage in many specialized plating applications.

- Growth of anodized Al/Mg corrosion coatings
- Low conductivity organic electrosynthesis
- Plating
- Electro remediation with porous electrodes - used in petroleum extraction and environmental applications
- Electrodeposition for Ti colored films
- Electrochemical reactor with high voltage bipolar electrodes
- High impedance biodiesel purity and many other organic media applications

Review **EchemLab XM**'s impedance accuracy contour (back page) to appreciate its measurement performance which is now brought to you in a smaller, lower cost package in the new **AppsLab XM** range of products.



Impedance at high DC voltage is used to study the growth of oxide coatings during the anodization process.



XM Potentiostat and FRA

EchemLab XM includes a reference grade high performance **XM** potentiostat. Its use of high technology waveform synthesis ensures smooth waveforms are applied in all modes of operation, whether connected direct to the cell, or via high voltage (HV100) amplifier or external boosters. Fast data acquisition is available at up to 1 MS/s for fast CV / fast pulse techniques.

Impedance (EIS) measurements couple this true reference grade potentiostat with a 40 MS/s frequency response analyzer (FRA) to ensure best accuracy to 1 MHz using Solartron Analytical's unique multi-point calibration techniques. Purest measurement results are guaranteed for all AC measurements by use of 40x oversampling.

EchemLab XM's advanced frequency response analyzer is able to perform single sine analysis, multisine/Fast Fourier Transform, and harmonic analysis (used for investigating non-linearity associated with cell failure mechanisms). All impedance techniques are available over the entire 1 MHz frequency range of the equipment, and via auxiliary inputs to study energy devices - anode/cathode and stack cells.

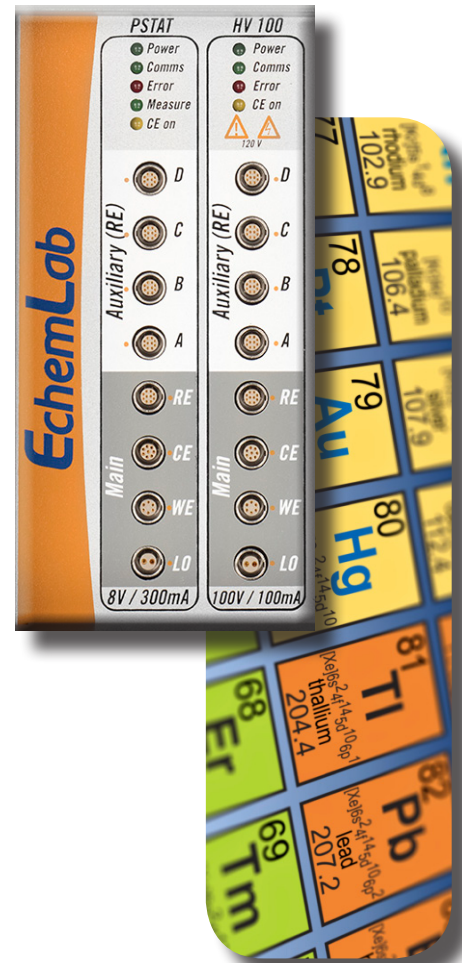

HV / Power Boosters

EchemLab XM includes a high voltage amplifier that provides ± 100 V polarization and compliance for testing specialized high impedance coatings and organic cells. The amplifier can be coupled with 100 V external power boosters for higher power applications.

12-wire Capability

Four differential auxiliary channels are included as standard, providing (together with the standard 4-terminal connections) a unique 12-wire capability that is able to monitor time domain voltage and impedance at multiple points in the test cell - enabling anode/cathode and cell stack testing at up to ± 100 V. The auxiliary channels are available in all modes of operation using direct pstat connection or via internal/external booster.

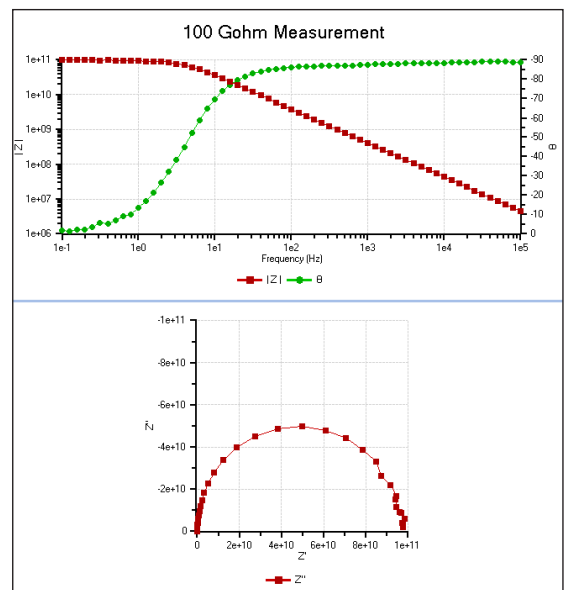

100 G Ω measurements in 3 terminal connection mode using built-in HV high voltage amplifier.

Xm-studio software easy as 1... 2... 3... 4...

XM-studio ECS software provides the complete range of facilities in one very easy to use package. From test setup, to experiment execution, to data analysis and final report; the software provides ready built templates to get you started, and tests can be setup and run in just a few mouse clicks:

1 Create new experiment

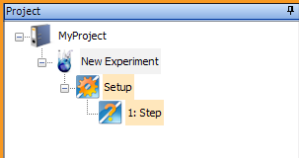

2 Select Step type (Impedance in this case):

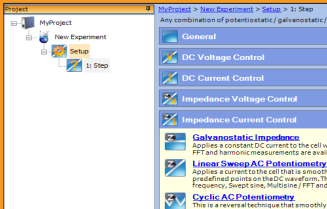

3 Check your cell connections - match the diagram in the "Experiment" menu, and click "Run"

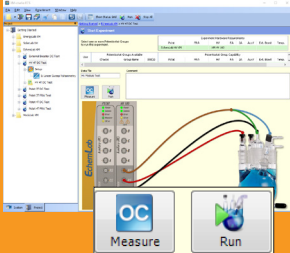

4 Analyze the data using equivalent circuit fitting, and automatically generate reports using your favorite word processor software

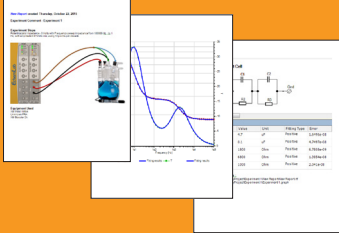

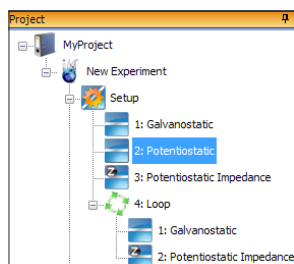

XM-studio ECS software is fully featured and graphically oriented for ease of use:

- Experiment sequences are setup using intuitive standard copy/paste, and drag & drop techniques.
- New experiments can be derived from previous experiments, by copying and then adjusting step parameters and test sequencing.

- Extensive use of graphical waveforms in the software enable full understanding of test parameters and experiment settings. The effect of parameter changes are seen real-time at setup, allowing setup errors to be identified and corrected before the test is run.

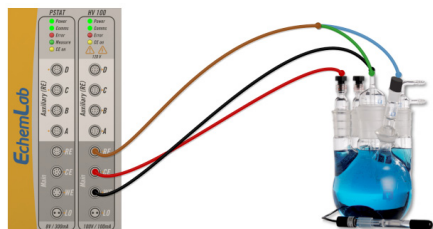
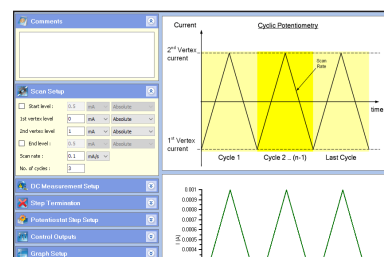

- **XM-studio ECS** software shows connection diagrams that ensure that your cell is correctly connected before the test starts.

- Equivalent circuit fitting is included, no need to export data
- R, C, L, Warburg constant phase elements, distributed elements...
- Tafel for corrosion and coatings

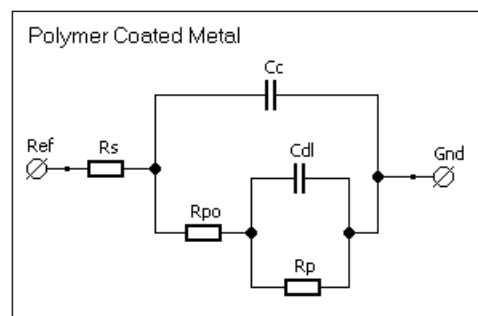

Accessories



EchemLab XM is specifically designed for fundamental electrochemical research applications but when paired with suitable accessories it can be used in other applications including corrosion and coatings, and energy including batteries, fuel cells, supercapacitors.

External Power Booster

EchemLab XM is compatible with external power boosters that extend its current and impedance measurement range - especially important for high voltage / high current applications.

- Floating design - enables tests on grounded cells
- Time domain and impedance tests on anodes/cathodes and cell stacks up to ± 100 V
- Can boost current up to 100 A and extend impedance measurements to $1 \mu\Omega$
- External boosters provide 100 kHz impedance bandwidth for SOFC and other high frequency applications
- Automatically controlled by **EchemLab XM** and **XM-studio ECS** software

Corrosion Cell

The cell permits a series of metal specimens and liquid environments to be tested quickly and uniformly. Most of the common electrochemical techniques for corrosion testing can be employed under aggressive conditions (except for HF)

Flat Cell

The practical design of the Flat Cell makes it simple to use for corrosion and/or coatings research. It can accommodate a wide range of electrode sizes, eliminating the need for machining or special mechanical procedures.

Rotator

The 636A is suitable for use in hydrodynamically modulated systems. Its solid state controlled servosystem allows the electrode speed to follow an input signal with minimum distortion. This excellent performance is due to the use of a high speed, low inertia, permanent magnet DC motor and a high voltage, bipolar power supply. The rotational speed is adjustable to within 1% of the input setting 50 to 10,000 RPM. A voltage signal proportional to the rotational speed is available as an output.

Applications

Analytical/Fundamental Research

EchemLab XM provides smooth analog waveforms in all modes of operation and is able to measure at high data acquisition rates (up to 1 MS/s) - ideal for high speed CV and pulse/step analytical techniques such as Normal Pulse Voltammetry NPV / Differential Pulse Voltammetry DPV.

EchemLab XM uniquely provides 100 V polarization and compliance for advanced testing using organic solvents and high resistivity environments.

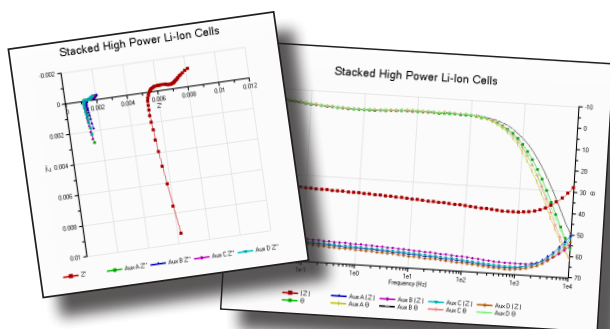

These example low-noise measurements are taken from a stack of Li-ion cells, and show the impedance of the overall stack and of individual cells in the stack.

Corrosion and Coatings

EchemLab XM's 100 V compliance and polarization voltage range coupled with sensitive current measurement is ideal for testing specialized low conductivity corrosion and coatings ($>100 \text{ G}\Omega$).

EchemLab XM provides harmonic and intermodulation measurements to investigate non-linear phenomena seen in corrosion applications. In addition, purely passive techniques are included - e.g. electrochemical noise using a Zero Resistance Ammeter ZRA.

As with all Solartron Analytical potentiostats systems, **EchemLab XM** provides floating measurements for environments where the sample may be directly or indirectly connected to ground.

Energy Research

EchemLab XM's high voltage capability is useful in applications such as stack testing. Uniquely the system is able to polarize stacks at up to 100 V, and its built-in high voltage auxiliary inputs can be used to identify individual bad cells within the stack, (using DC voltage and EIS impedance techniques).

External boosters can also be added for testing higher power stacks and cells at up to 100 V / 100 A.



Specifications

Potentiostat/Galvanostat	
Cell connections	2, 3, or 4 terminal
Instrument Connections	CE, WE, RE, LO
Floating measurements	yes
Impedance measurement bandwidth	1 MHz (via FRA)
Maximum time record	Unlimited
IR compensation	yes

Counter Electrode (CE)	
Smooth scan generator	64 MS/s interpolated and filtered
Voltage polarization (and compliance) range	Pstat ± 8 V / HV ± 100 V
Current polarization range	Pstat ± 300 mA / HV ± 100 mA
Recommended voltage scan rate	25 kV/s to 1 μ V/s
Recommended current scan rate	1 kA/s to 200 μ A/s
Bandwidth (decade steps)	1 MHz to 10 Hz
Polarization V/I error (setting+range)	0.1% + 0.1%
Minimum pulse duration	1 μ s
Slew rate	>10 V/ μ s

Reference Inputs (RE)	
Connections	Differential input
Cable Shields	Driven (3T) / Ground (4T)
Maximum voltage Measurement	Pstat ± 8 V / HV ± 100 V
Ranges	Pstat 8 V to 3 mV / HV 100 V to 37.5 mV
Accuracy (reading % + range % + offset)	0.1% + 0.05% + 100 μ V
Maximum resolution	Pstat 1 μ V / HV 1.25 μ V
Input impedance	>100 G Ω , <28 pF (3T)
Input bias current	<10 pA
Maximum ADC sample rate	1 MS/s

Working Electrode (WE)	
Maximum current	Pstat ± 300 mA / HV ± 100 mA
Ranges	300 mA to 30 nA
Accuracy (reading % + range % + offset)	0.1% + 0.05% + 30 fA
Maximum resolution	1.5 pA
Compliance voltage range (floating)	Pstat ± 8 V / HV ± 100 V
Maximum ADC sample rate	1 MS/s

Auxiliary electrodes (A, B, C, D)	
Differential Auxiliary Electrodes	4 (same spec. as RE)
DC Measurement	Synchronized to RE
Impedance measurement bandwidth	1 MHz (via FRA)

Frequency Response Analyzer	
Maximum sample rate	40 MS/s
Frequency range	10 μ Hz to 1 MHz
Frequency resolution	1 in 65,000,000
Frequency error	± 100 ppm
Minimum \int time per measurement (single sine, FFT or harmonic)	10 ms

Signal Output	
Waveform	Single sine, multi-sine
Single Sine	Linear / logarithmic
Multi-sine / harmonic frequencies	All or selected

Analysis channels	
Accuracy (ratio)	$\pm 0.1\%$, $\pm 0.1^\circ$
Anti-alias, digital filters, DC bias reject	Automatic
Analysis channels	RE, WE, Aux A/B/C/D
Analysis modes:	Single sine, FFT, harmonic
DC Bias rejection	Automatic

Impedance Accuracy

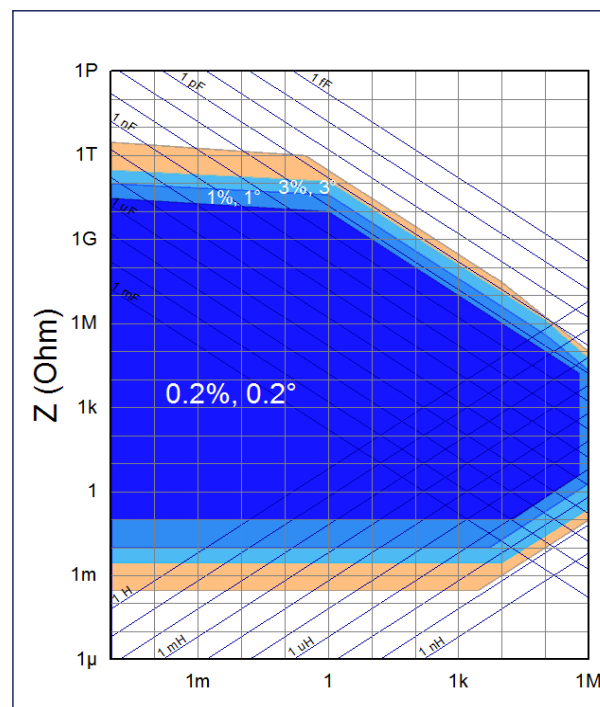

- External high power boosters extend accuracy to 1 $\mu\Omega$
- 3T connections for high impedance / low capacitance measurements, 4T otherwise
- Gstat mode < 1 Ω
- Faraday cage and suitable screening recommended

USA

Tel: (865) 425-1289

Visit our website for a complete list of our global offices and authorized agents

www.solartronanalytical.com si.info@ametech.com

Europe

Tel: +44 (0) 1252 556800

solartron
analytical

AMETEK

©Copyright 2016 AMETEK, Inc. All Rights Reserved

0716B