

- "Application-Matched" P-type HPGe Detectors, optimized for specific sample types, gamma energy ranges and measurement geometries.
- Know how your new HPGe detector will perform before you buy it!
- Best absolute efficiency for the given IEEE standard relative efficiency in your counting geometry.
- Warranted Crystal Dimensions ensure measurement performance.
- Reproducible dimensions mean reproducible performance. . . no surprises.
- Full range of PopTop Cryostats and options.



PROFILE GEM detectors are a first in germanium detectors; a range of detectors from which you can choose the best solution for your application from specified crystal dimensions. Nominal relative efficiency specifications are provided in order to help relate relative efficiency to terms of crystal dimensions. The resolution is measured according to the IEEE standard. If a particular PROFILE series detector is available from the ORTEC detector stocklist, then the ACTUAL MEASURED specifications may be inspected before purchase.

F-Series PROFILE GEM Detectors

F-Series PROFILE detectors employ "over-square" (diameter > length) coaxial structures. For a given relative (IEEE) efficiency, the F-Series represents the "best use" of the germanium material in terms of producing the maximum absolute counting efficiency for on-endcap or "close geometry" extended samples, such as:

- Point sources on-endcap
- Filter Paper Samples on-endcap
- Samples presented in bottles and pots on-endcap
- Bio-Assay applications (e.g., lung monitoring)
- Waste Drum monitoring

In addition, the over-square geometry helps improve low-energy resolution by reduced crystal capacitance.

FX-Series PROFILE GEM Detectors

- All the advantages of the F-Series PROFILE detector with an ULTRA-thin Entrance Window.
- Excellent warranted performance specifications.

FX-Series PROFILE GEM detectors employ a proprietary thin entrance window in order to improve low energy efficiency. The FX-series can extend the useful energy range down to 10 keV and below, which maintains the excellent peak shape and resolution characteristics of the PROFILE series.

Figure 2 shows absolute efficiency curves for a 70 mm diameter x 15 mm length source on endcap for an 85 mm diameter GEM-FX8530, compared to a GEM80 76 mm diameter x 87 mm length.¹ Note the much higher absolute efficiency of the FX85 at all energies below 160 keV. At 59 keV, the FX is SIX times more efficient, and below that the efficiency of the GEM80 falls off due to the thick (~700 μm) contact. The FX detector has an ultra thin contact (~10 μm Ge) allowing good transmission at 22 keV and below.

Figure 3 shows similar spectra from the three detectors compared, in the energy range up to ~130 keV. The spectra are taken from a mixed isotope calibration source. In all cases, the cursor is centered on the 59 keV ²⁴¹Am peak. To the right is the 88 keV peak from ¹⁰⁹Cd. In both the GEM-FX and the GMX, the thin entrance window clearly transmits the low-energy gammas in the 22–24 keV region. These peaks are entirely absent from the spectrum of the GEM80, even though the 88 keV is visible.

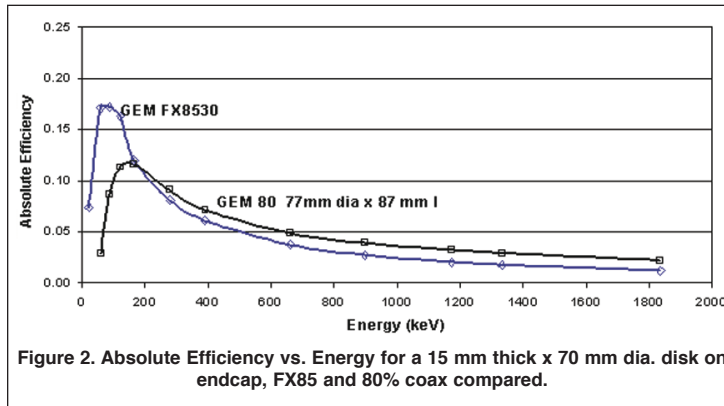
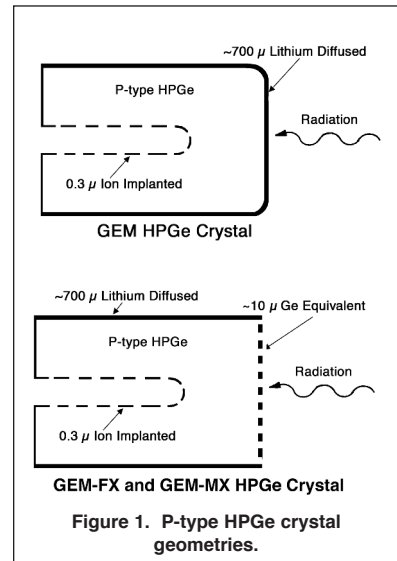

Figure 2. Absolute Efficiency vs. Energy for a 15 mm thick x 70 mm dia. disk on endcap, FX85 and 80% coax compared.

¹Data taken from "The Evaluation of True Coincidence Summing Effect on CTBTO-Type Sample Geometry," R.M. Keyser, ORTEC. Presented at IEEE Nuclear Science Symposium, Portland, Oregon, October 19–25, 2003.

PROFILE Coaxial HPGe Photon Detector Product Configuration Guide

General Guidelines for Choosing an F-Series or FX-Series PROFILE GEM Detector

For a close or on-endcap sample, the detector diameter should ideally exceed the sample diameter by 20% or more. Beyond 30% the gain in efficiency is small. Another point, often missed, is if the detector diameter exceeds the sample diameter by 20% or more, then any errors due to irreproducibility of sample position will be minimal.

When budget limits are considered, first select the largest diameter up to the optimum diameter, then specify a deeper detector to further increase the absolute efficiency, specifically at higher energies. For samples to be counted in geometries similar to those listed above, choose an F-Series PROFILE detector with a diameter 20% (or more) larger than the sample to ensure the highest absolute efficiency for a given relative (IEEE) efficiency. Over-square detectors can often achieve better low-energy resolution than longer, smaller diameter detectors of the same relative efficiency.

M-Series PROFILE GEM Detectors

The M-Series detectors are designed specifically to provide optimum geometry for use with Marinelli beakers. These are made with the endcap diameter "filled with crystal" and the length slightly longer than the diameter, which maximizes the overall absolute efficiency for a Marinelli beaker. This is the most common beaker where the well diameter is equal to its length.

MX-Series PROFILE GEM Detectors

The MX-Series detectors provide all the attributes of the M-Series detectors combined with a thin entrance window. This expands the lowest usable energy to below 10 keV while maintaining the efficiency at higher energies. Nuclides such as ^{241}Am and ^{210}Pb may be measured while providing excellent efficiency to over 3000 keV for higher energy emitters; all in a single detector. The largest of these detectors provides the maximum efficiency available in a single detector for energies greater than 3 MeV.

General Guidelines for Choosing an M-Series or MX-Series PROFILE GEM Detector

Choosing the optimum M-Series detector for use with a specific Marinelli beaker could not be easier: simply choose the detector with the tightest fit inside the Marinelli beaker well!

An F-Series detector may be used in a Marinelli geometry, but will have a lower efficiency than an M-Series of the same diameter. Correspondingly, an M-Series detector may be used as a substitute for an F-Series in an on-endcap type of geometry. For the same diameter, the M-Series will give slightly higher efficiency (improvement increasing with increasing energy).

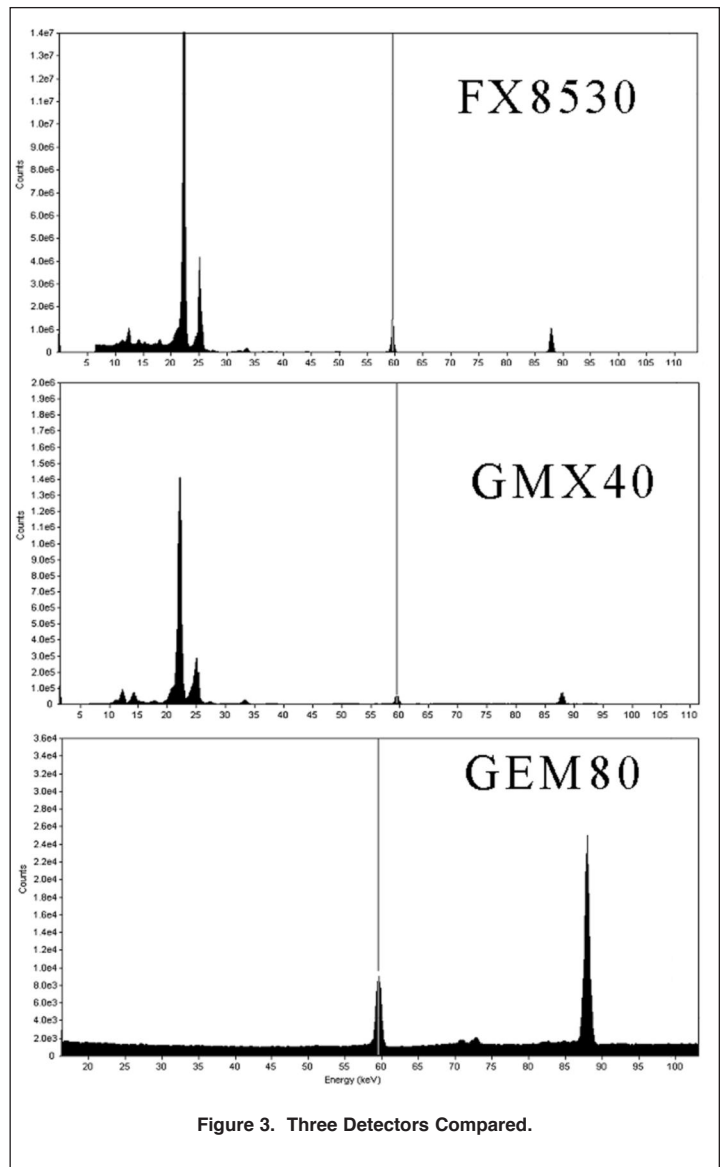

Figure 3. Three Detectors Compared.

PROFILE Coaxial HPGe Photon Detector Product Configuration Guide

Overall Guidelines on the Choice of PROFILE Series GEM					
Source Energy (keV)	Marinelli Beaker	Near Point Source	Far Point Source	Small Extended Source	Large Extended Source*
5 to 200	N/A	LO-AX	LO-AX	LO-AX	LO-AX
10 to 1500	PROFILE MX	PROFILE FX	PROFILE FX	PROFILE FX	PROFILE FX
10 to 3000	PROFILE MX	PROFILE MX	PROFILE MX	PROFILE MX	PROFILE MX
50 to 200	PROFILE M	PROFILE F	PROFILE F	PROFILE F	PROFILE F
200 to 1500	PROFILE M	PROFILE F	PROFILE F	PROFILE F	PROFILE F
1500 to 3000	PROFILE M	PROFILE M	PROFILE M	PROFILE M	PROFILE M
above 3000	PROFILE-M94100 PROFILE-MX94100 GEM	PROFILE-M94100 PROFILE-MX94100 GEM	PROFILE-M94100 PROFILE-MX94100 GEM	PROFILE-M94100 PROFILE-MX94100 GEM	PROFILE-M94100 PROFILE-MX94100 GEM

*For extended sources; including filters, bottles, and Petri dishes, the detector diameter should be $\geq 1.2 \times$ sample diameter for best results.
If high-energy emitters dominate when the nuclides of primary interest are at lower energies, the higher peak to Compton ratio of a deeper detector may result in improved detection limits for the lower energy emitters.

The Following Specifications are Provided for Each PROFILE Series Detector

- Energy resolution at 1.33-MeV photons from ^{60}Co at optimum shaping time.
- Active dimensions.
- Nominal values for relative efficiency are given (not a specification).
- Peak-to-Compton ratio for ^{60}Co 1.33-MeV peak.
- Nominal values for peak shape ratio for the full-width tenth-maximum to the full-width half-maximum for ^{60}Co 1.33-MeV peak are given (not a specification).
- Energy resolution at 122-keV photons from ^{57}Co at optimum shaping time for the GEM-F, GEM-M, and GEM-MX.
- Energy resolution at 122-keV photons and 14.4-keV photons from ^{57}Co at optimum shaping time for the GEM-FX and GEM-MX.
- Energy resolution at 46-keV photons from ^{210}Pb at optimum shaping time for the GEM-FX.

Configuration Guidelines

PopTop or Streamline (non-PopTop) Configuration

The essence of a PopTop detector system is that the HPGe detector element cryostat, preamplifier, and high voltage filter are housed in a detector “capsule” which is then attached to an appropriate cryostat (Figure 4.)

In so called Streamline systems, the detector capsule is NOT demountable. Detector capsule and cryostat share the same vacuum. In configuration terms, this requires a cryostat or cryostat/dewar selection with the cryostat having a matching diameter to the capsule endcap. A cryostat must always be ordered with a Streamline capsule, because they are integral.

The actual PopTop capsule has its own vacuum. It can be mounted on any of the available cryostats, cryostat/dewar combinations, or the X-COOLER III mechanical cooling system.

Steps to Configure Your ORTEC HPGe Detector

1) Configure the Detector Model

- Capsule type (PopTop or Streamline)
- Ge Crystal dimensions and specifications
- Endcap and window
- Mount
- Preamplifier
- High Voltage Filter
- Cable Package

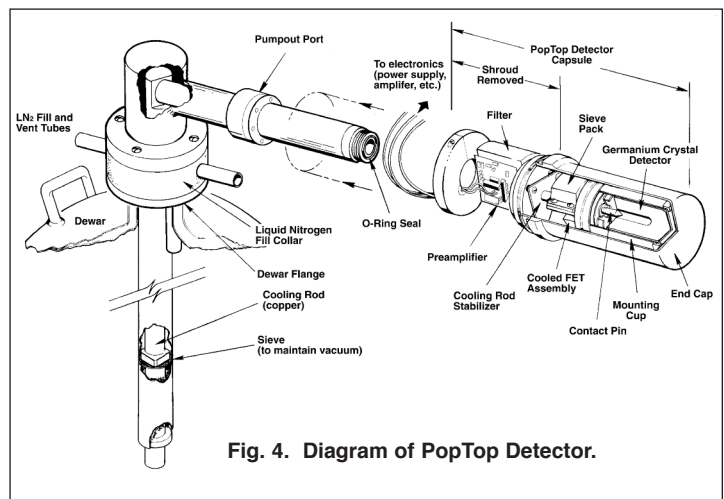

Fig. 4. Diagram of PopTop Detector.

PROFILE Coaxial HPGe Photon Detector

Product Configuration Guide

Options are available for the detector model that can change specific materials used in the construction of the detector endcap, cup, and mount. Preamplifier options are also available.

2) Configure the Cryostat/Dewar Model

- Vertical Dipstick style (separate Dewar)
- Horizontal Dipstick style (separate Dewar)
- Portable with all-position or multi-position cryostat/dewar models
- Downlooking designed to be oriented with the detector pointing down
- Sideloooking designed to be oriented with the detector horizontal at the bottom of the dewar
- “J” configurations designed with the detector attached near the bottom of the dewar and a right angle bend in the cryostat orienting the detector to look up.

A cryostat and dewar or other cooling device are required for operation.

If a PopTop detector has been selected, you can choose a PopTop style cryostat, cryostat/dewar combination or the X-COOLER III mechanical cooler.

If a Streamline detector has been selected, you must choose a cryostat or cryostat/dewar model for the detector to be mounted on and vacuum sealed. The cryostat or cryostat/dewar combination diameter must match the endcap diameter of the selected detector.

Detector Options

Harsh Environment Option (-HE)

The Harsh Environment option is a rugged carbon fiber endcap with a sealed electronics housing featuring a replaceable desiccant pack which ensures that the electronics stay 100% dry and indicates when it needs to be replaced.

PROFILE series detectors in PopTop capsules of 83 mm diameter or larger can be supplied with this option.

Ultra-High Count-Rate Preamplifier Option (-PL)

The Ultra-High Count-Rate Preamplifier (transistor-reset preamplifier), which can handle input count rates up to 1,000,000 counts/s at 1 MeV, offers the added benefit of having no feedback resistor.

SMART-1 Option (-SMP)

The SMART-1 option monitors and reports on vital system functions, and can save authentication codes and report the code at a later time. It has the high voltage included, so none of the instruments require an external high-voltage power supply.

The SMART-1 is housed in a rugged ABS molded plastic enclosure and is permanently attached to the detector endcap via a molded-strain-relieved sealed cable. This eliminates the possibility that the detector will suffer severe damage from moisture leaking into high-voltage connectors. The SMART-1 can be positioned in any convenient place and does not interfere with shielding or other mounting hardware.

Remote Preamplifier Option (-HJ)

This option allows all the preamplifier and high voltage connections to be outside a shield and removes the preamplifier and high voltage filter from the “line-of-sight” to the Ge crystal. For low background applications, this option eliminates any possible preamplifier or high voltage filter components that may add to the background inside a shield.

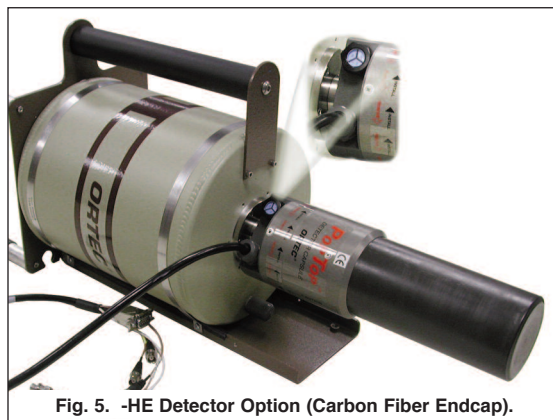

Fig. 5. -HE Detector Option (Carbon Fiber Endcap).

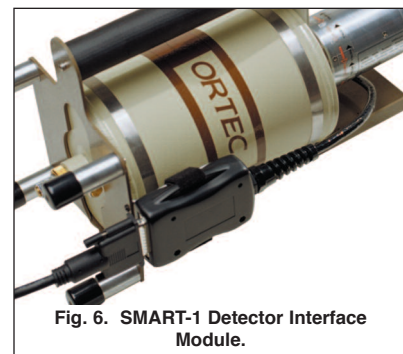

Fig. 6. SMART-1 Detector Interface Module.

PROFILE Coaxial HPGe Photon Detector Product Configuration Guide

Low-Background Carbon Fiber Endcap Options (-RB, -LB-C, and -XLB-C)

Carbon Fiber is as strong as Al, Mg, and Cu, creates less background, does not corrode, and can detect energies less than 10 keV.

This lower background material allows for lower Minimum Detectable Activity (MDA) for a specific counting time, which provides another step in increasing sample throughput in low-background counting applications. The lower Z of Carbon Fiber provides a low-energy window without the additional background found in most alloys. See Figures 7 and 8 for transmission characteristics of the Be and carbon fiber windows.

Carbon Fiber, unlike Beryllium, is non-toxic and can be cleaned with most laboratory solvents such as methanol, trichloroethylene, and acetone. Soap and water may also be used. Abrasive cleaners should not be used.

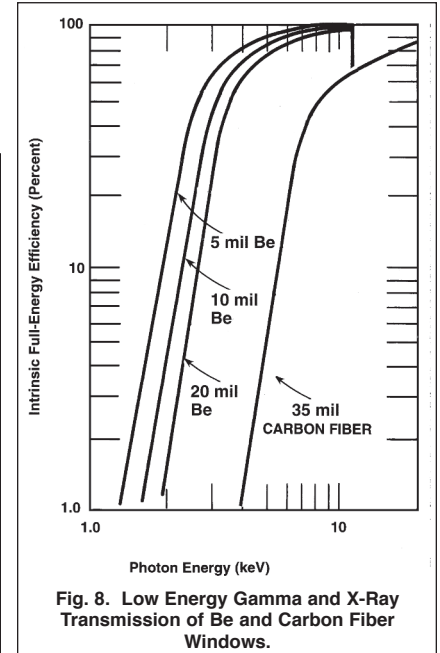
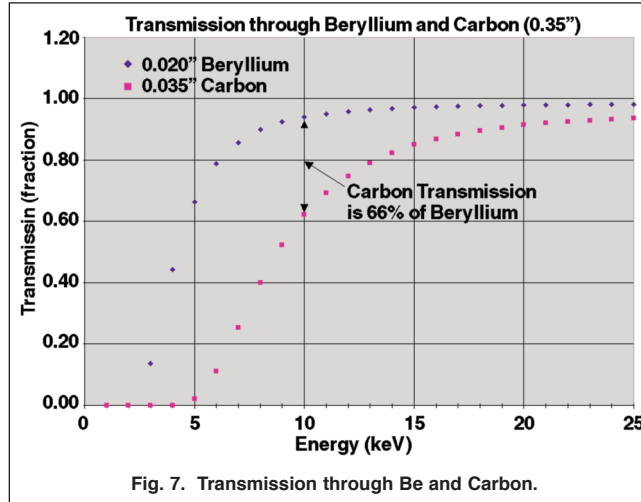

Defining the Detector Model

• See ordering information for option compatibility.

Base Model (example)	PopTop or Streamline	Window Option (if required)	Preamplifier Option (if required)	High Voltage Option (if required)
GEM-M5970	P4 (PopTop) (Streamline)	-RB -HE -LB-C -XLB-C	-PL -HJ	-SMP

PROFILE Coaxial HPGe Photon Detector Product Configuration Guide

Streamline GEM-F and GEM-M Detector Capsule

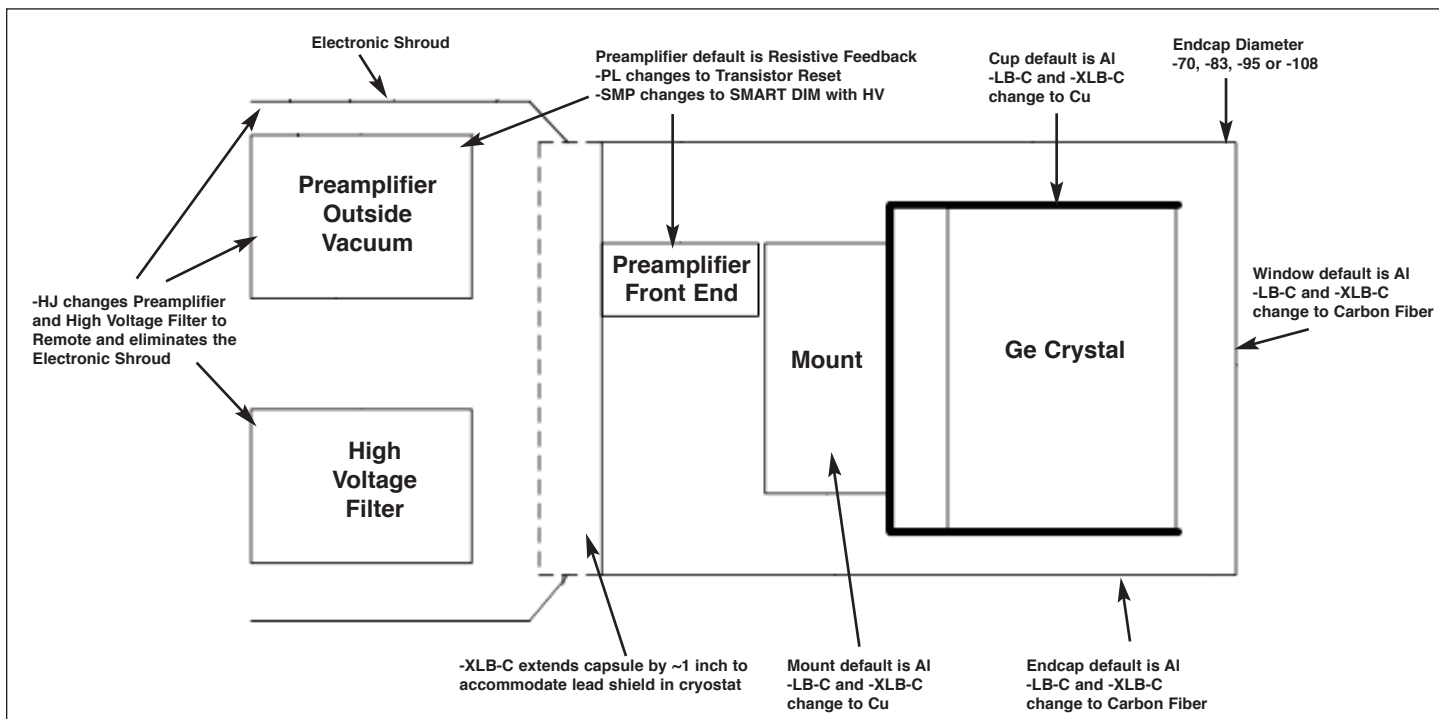

Streamline GEM-FX and GEM-MX Detector Capsule

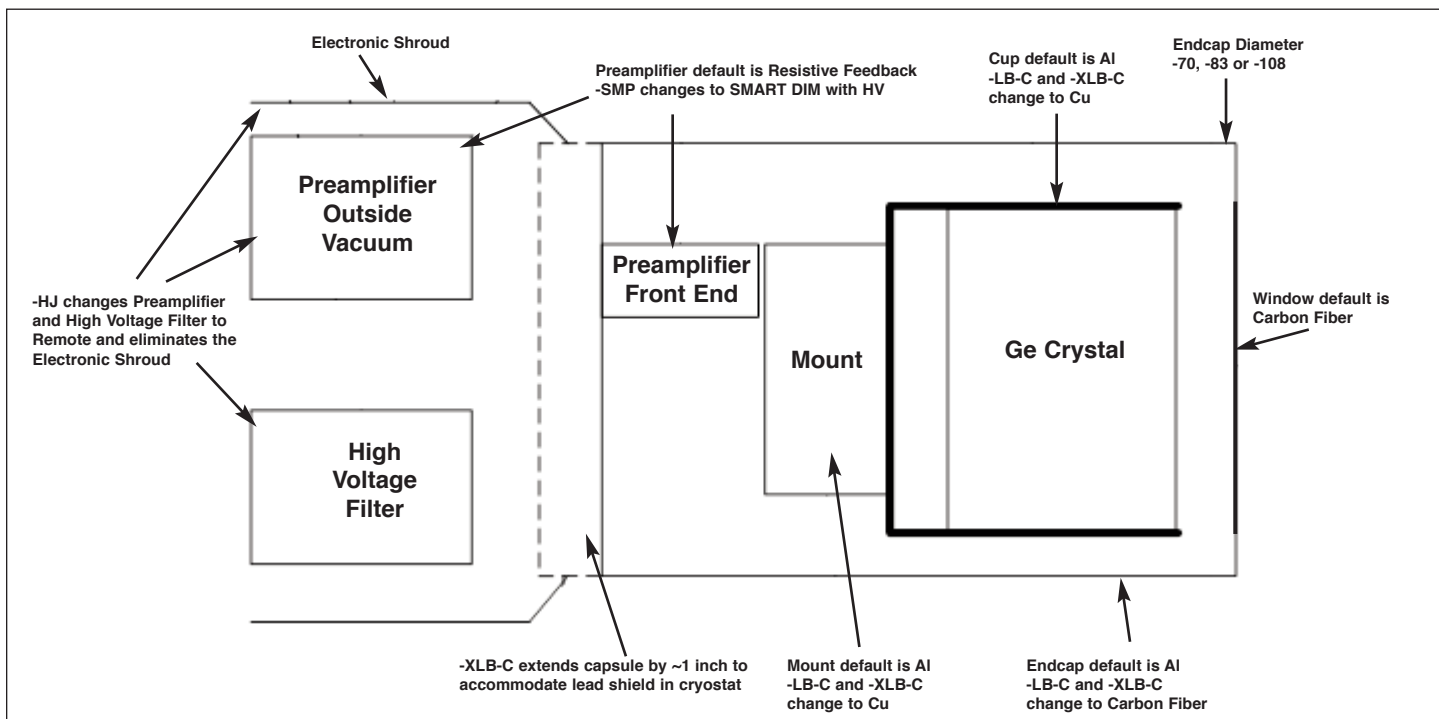

PROFILE Coaxial HPGe Photon Detector Product Configuration Guide

PopTop GEM-M and GEM-F Detector Capsule

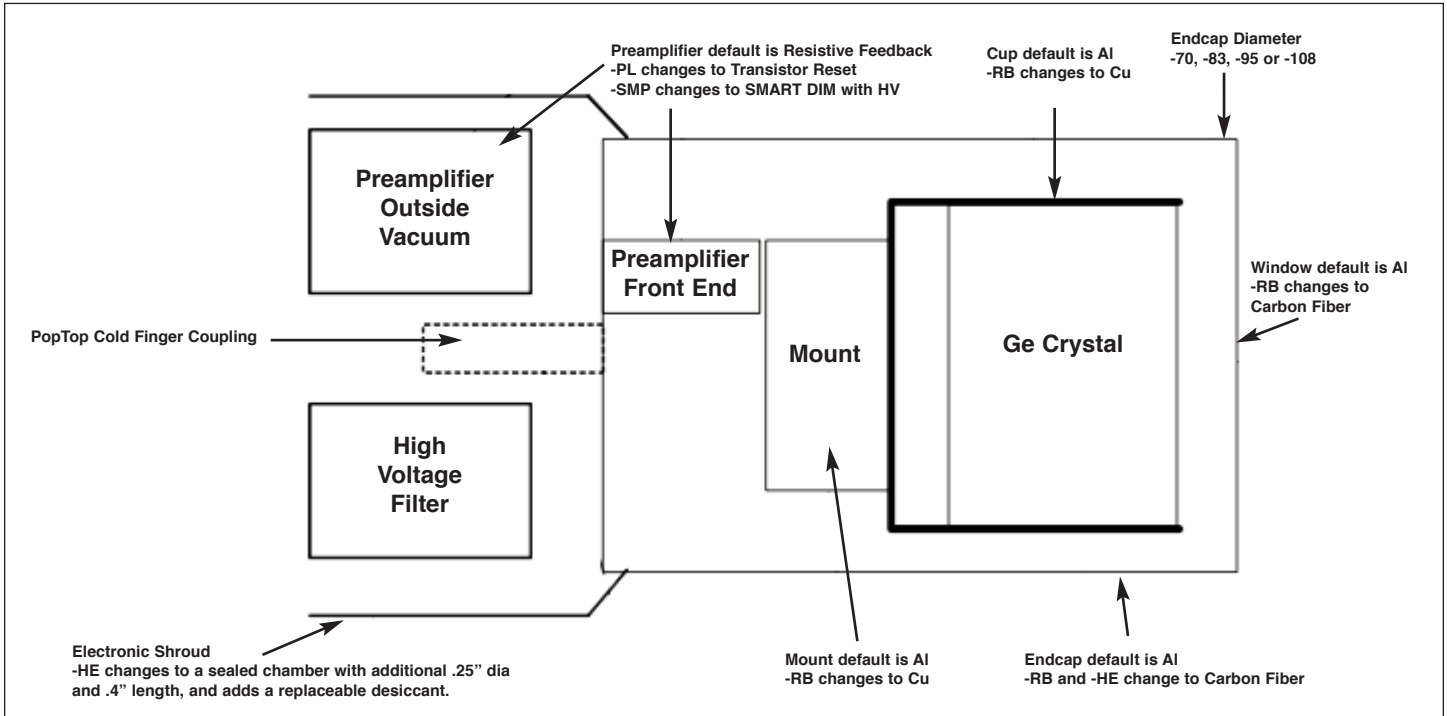

PopTop GEM-FX and GEM-MX Detector Capsule

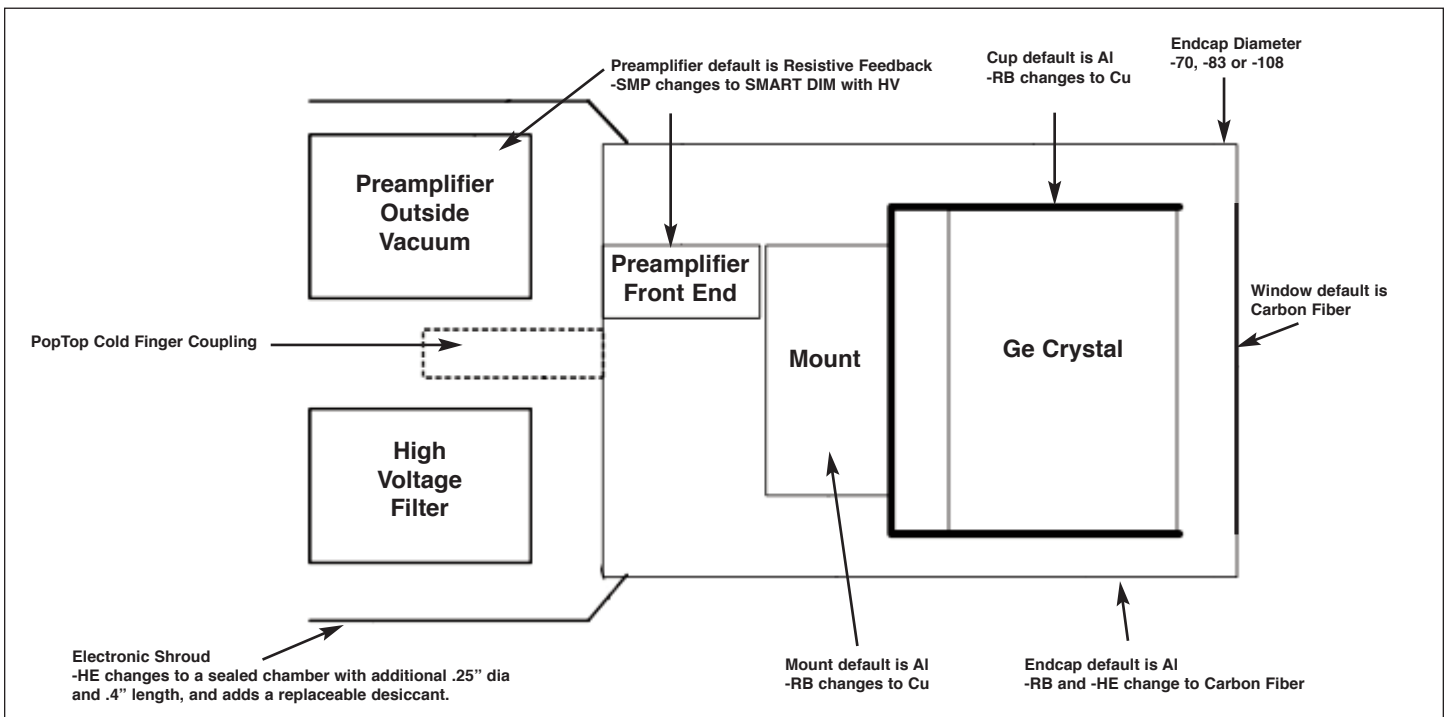

PROFILE Coaxial HPGe Photon Detector Product Configuration Guide

Streamline Cryostat and Cryostat/Dewar Assemblies

Streamline systems (detector capsule and cryostat) share the same vacuum, requiring a cryostat or cryostat/dewar selection with the cryostat having a matching diameter to the capsule endcap.

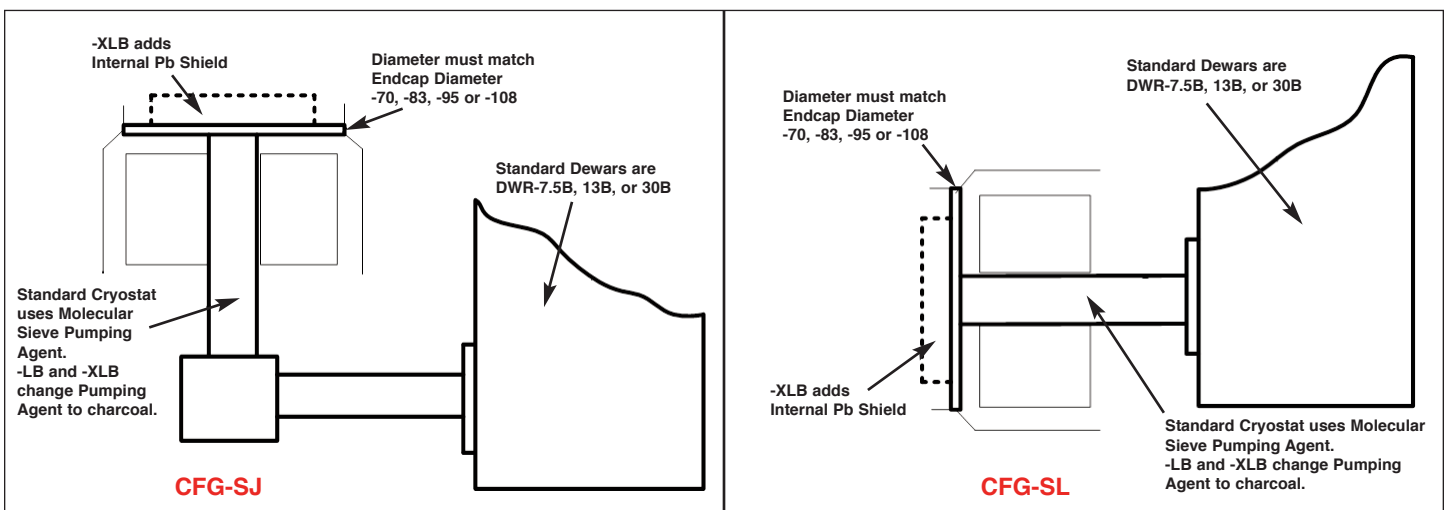
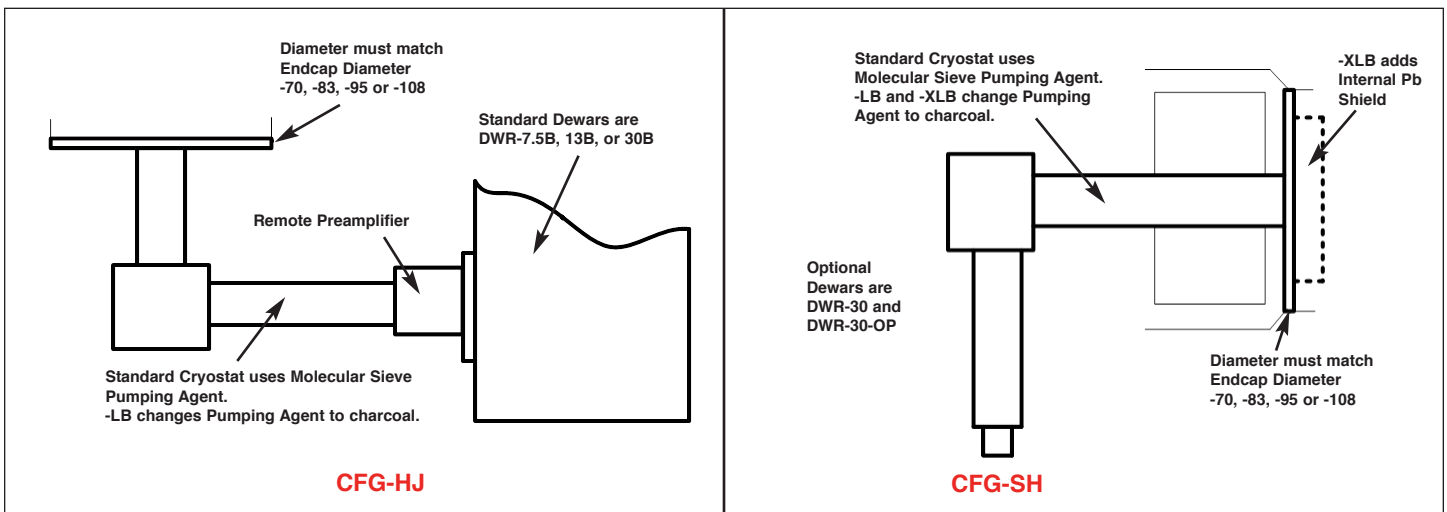
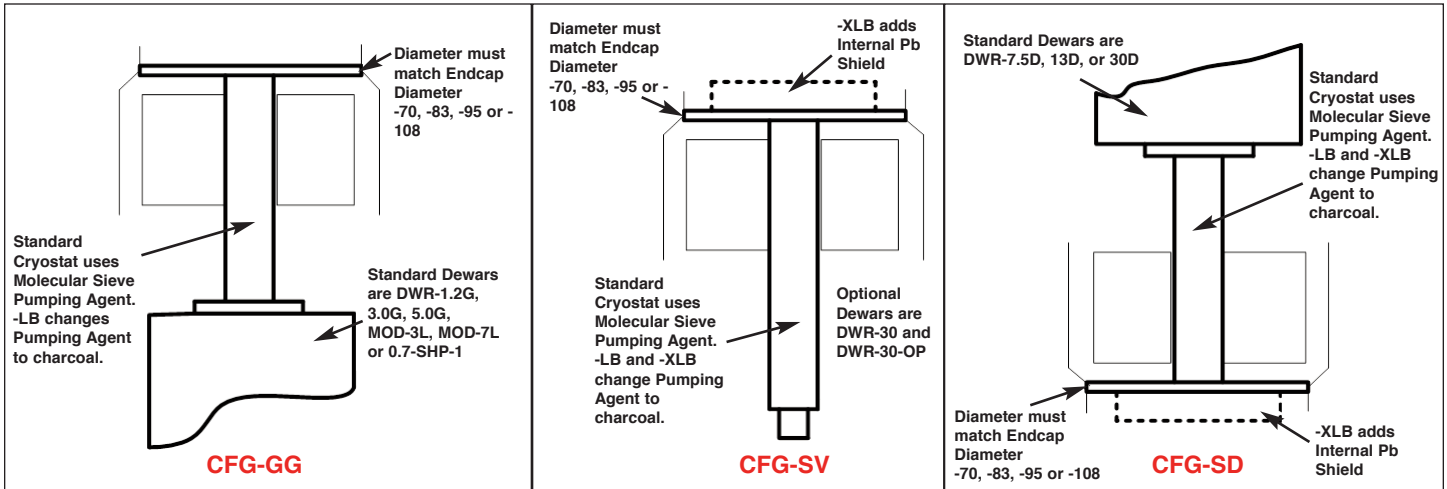

PROFILE Coaxial HPGe Photon Detector Product Configuration Guide

PopTop and Streamline Dimensional Data

Streamline systems (detector capsule and cryostat) share the same vacuum, requiring a cryostat or cryostat/dewar selection with the cryostat having a matching diameter to the capsule endcap. A cryostat must be ordered with a Streamline capsule.

The PopTop capsule contains a vacuum unto itself. It can be mounted on any of the available cryostats, cryostat/dewar combinations, or the X-COOLER III mechanical cooling system.

The cryostat and dewar drawings that follow are to be used in conjunction with the accompanying tables of dimensions.

Note: Cryostat/Dewar drawings are NOT to scale, see tables that follow for complete dimensions.

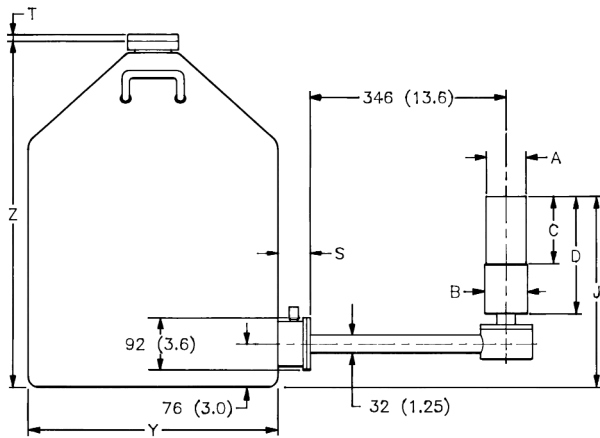

CFG-SJ, DWR-30B (or -13B or -7.5B)

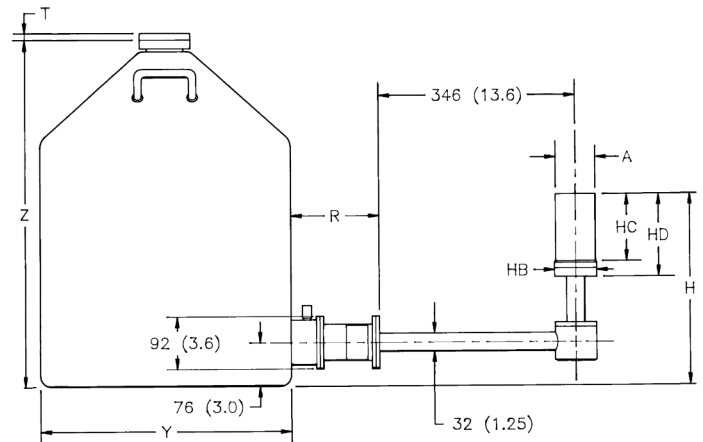

CFG-HJ, DWR-30B (or -13B or -7.5B)

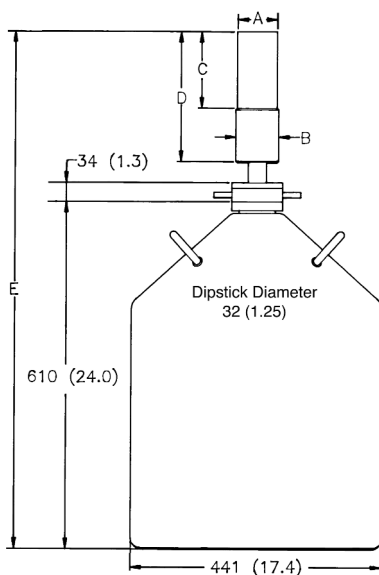

CFG-SV, DWR-30

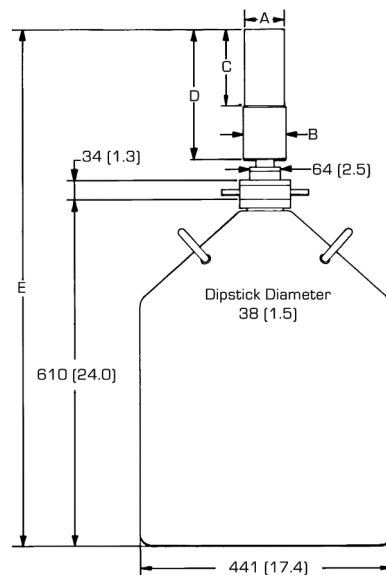

CFG-PV4, DWR-30

PROFILE Coaxial HPGe Photon Detector Product Configuration Guide

Note: Cryostat/Dewar drawings are NOT to scale, see tables that follow for complete dimensions.

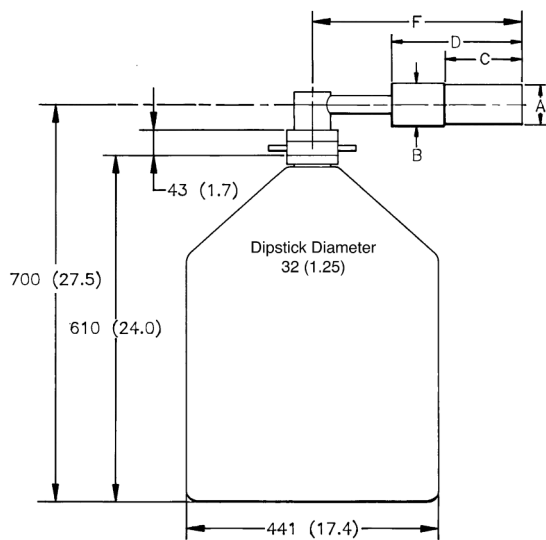

CFG-SH, DWR-30

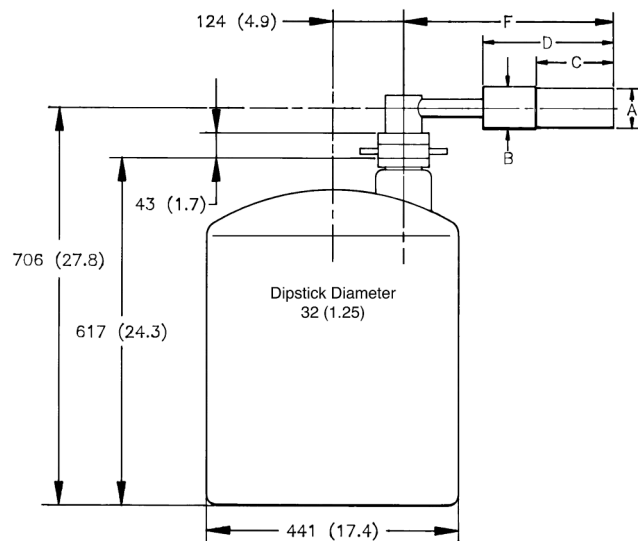

CFG-SH, DWR-30-OP

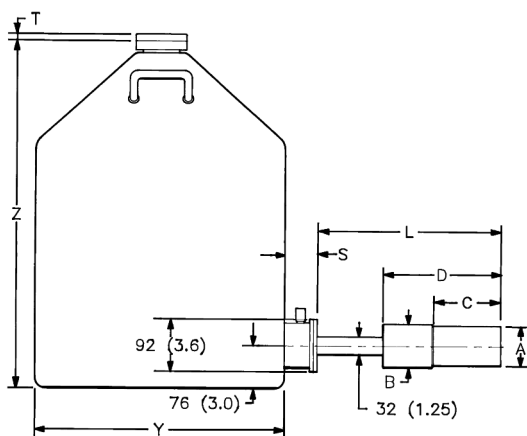

**CFG-PS4-30 (or -13 or -7.5)
or
CFG-SL, DWR-30B (or -13B or -7.5B)**

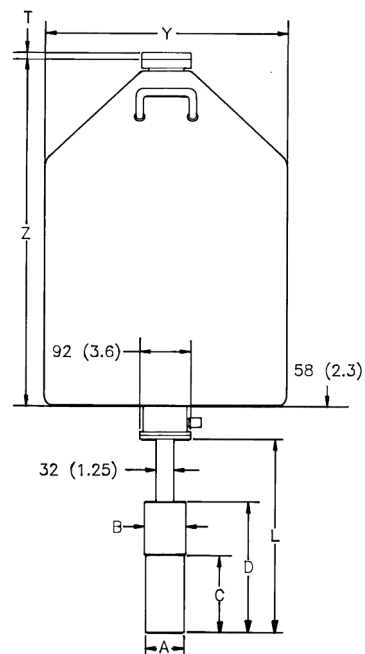

**CFG-PD4-30 (or -13 or -7.5)
or
CFG-SD, DWR-30D (or -13D or -7.5D)**

PROFILE Coaxial HPGe Photon Detector Product Configuration Guide

Note: Cryostat/Dewar drawings are NOT to scale, see tables that follow for complete dimensions.

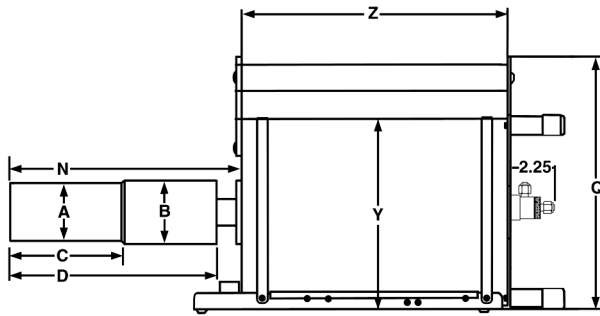

**CFG-PG4-1.2 (or -3 or -5)
or
CFG-GG, DWR-1.2G (or -3.0G, -5.0G)**

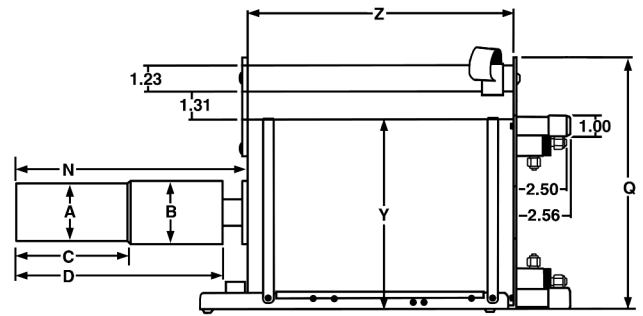

**CFG-PMOD4-3 (or -7)
or
CFG-GG, DWR-MOD3L (or -MOD7L)**

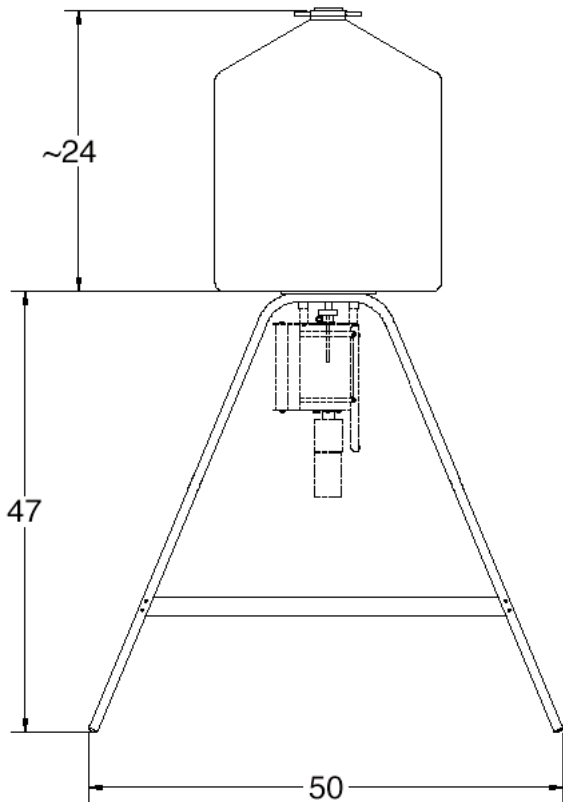

DWR-S/F

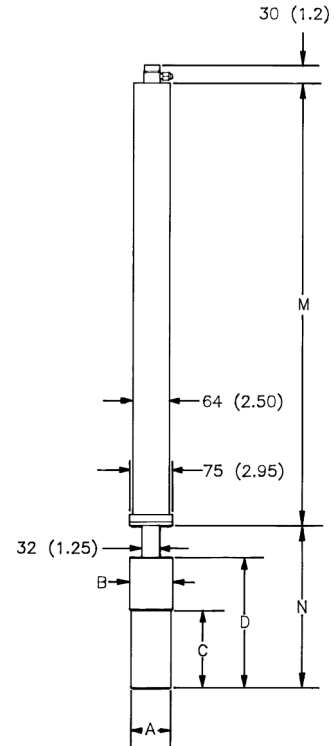

**CFG-PSHP4
or
CFG-GG, DWR-0.7-SHP-1**

PROFILE Coaxial HPGe Photon Detector Product Configuration Guide

Note: Cryostat/Dewar drawings are NOT to scale, see tables that follow for complete dimensions.

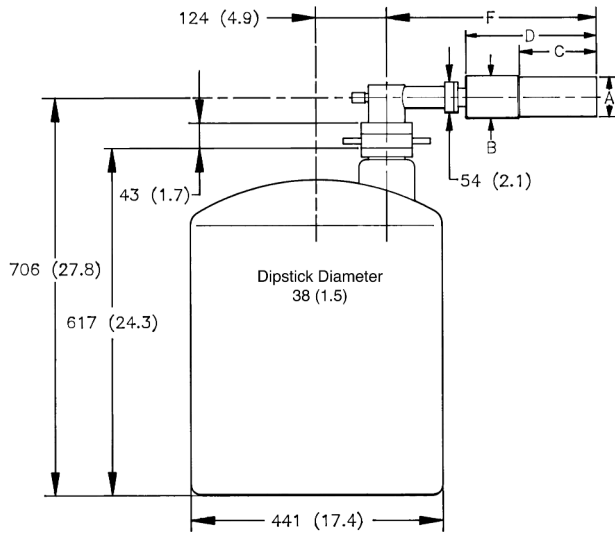

CFG-PH4, DWR-30-OP

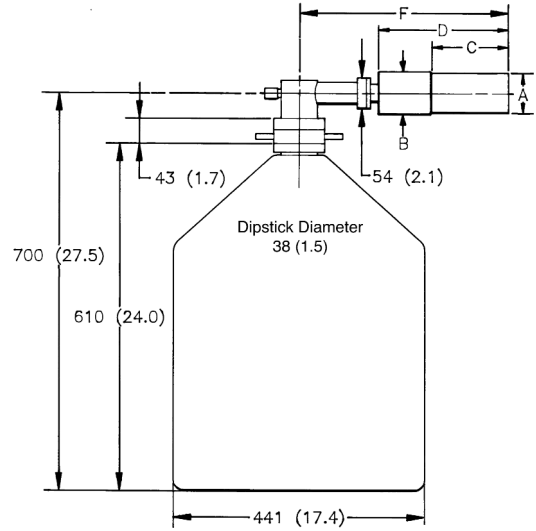

CFG-PH4, DWR-30

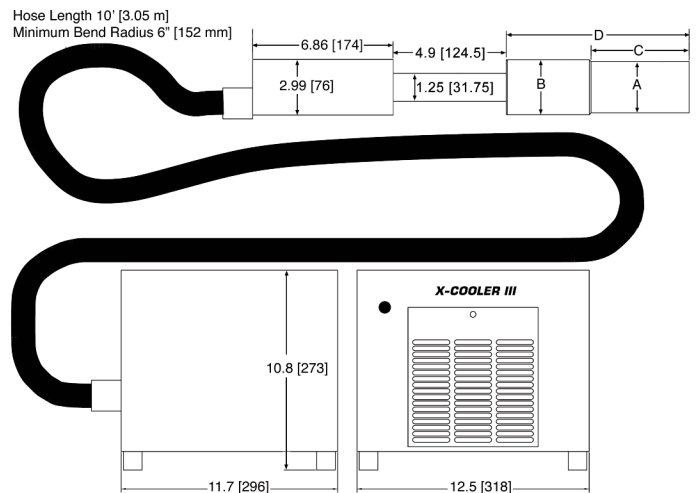

CFG-X-COOL-III

PROFILE Coaxial HPGe Photon Detector Product Configuration Guide

PopTop PROFILE Series Detector Dimensions

- Dimensions are for reference only and subject to change.
- If dimensional constraints are critical, contact the factory.

Endcap Model (dia. mm)			-70	-83	-95	-108
Dim.	Unit	Tol.				
A	mm (in)	0.3 (0.01)	70 (2.75)	83 (3.25)	95 (3.75)	108 (4.25)
B	mm (in)	0.3 (0.01)	75 (2.95)	88 (3.45)	100 (3.95)	113 (4.45)
C	mm (in)	5 (0.2)	134 (5.3)	168 (6.6)	193 (7.6)	207 (8.2)
D	mm (in)	8 (0.3)	250 (9.8)	282 (11.2)	309 (12.2)	323 (12.7)
E	mm (in)	18 (0.7)	947 (37.3)	982 (38.6)	1007 (39.7)	1019 (40.1)
F	mm (in)	10 (0.4)	396 (15.6)	429 (16.9)	455 (17.9)	469 (18.5)
L	mm (in)	10 (0.4)	338 (13.3)	371 (14.6)	396 (15.6)	412 (16.2)
M	mm (in)	8 (0.3)	790 (31.1)	X X	X X	X X
N	mm (in)	10 (0.4)	278 (10.9)	312 (12.3)	338 (13.3)	348 (13.7)

PROFILE Coaxial HPGe Photon Detector Product Configuration Guide

Streamline PROFILE M and F Series Detector Dimensions

- Dimensions are for reference only and subject to change.
- If dimensional constraints are critical, contact the factory.

			Standard or LB				XLB			
Endcap Model (dia. mm)			-70	-83	-95	-108	-70	-83	-95	-108
Dim.	Unit	Tol.								
A	mm (in)	0.3 (0.01)	70 (2.75)	83 (3.25)	95 (3.75)	108 (4.25)	70 (2.75)	83 (3.25)	95 (3.75)	108 (4.25)
B	mm (in)	0.3 (0.01)	75 (2.95)	88 (3.45)	100 (3.95)	113 (4.45)	75 (2.95)	88 (3.45)	100 (3.95)	113 (4.45)
C	mm (in)	5 (0.2)	134 (5.3)	134 (5.3)	160 (6.3)	197 (7.8)	160 (6.3)	160 (6.3)	185 (7.3)	197 (7.8)
D	mm (in)	8 (0.3)	246 (9.7)	259 (10.2)	284 (11.2)	322 (12.7)	272 (10.7)	284 (11.2)	310 (12.2)	322 (12.7)
E	mm (in)	18 (0.7)	916 (36.1)	932 (36.7)	957 (37.7)	995 (39.2)	941 (37.1)	958 (37.7)	983 (38.7)	995 (39.2)
F	mm (in)	10 (0.4)	368 (14.5)	381 (15.0)	406 (16.0)	445 (17.5)	394 (15.5)	406 (16.0)	432 (17.0)	445 (17.5)
H	mm (in)	18 (0.7)	351 (13.8)	364 (14.3)	390 (15.3)	428 (16.9)	X X	X X	X X	X X
HB	mm (in)	0.3 (0.1)	73 (2.9)	85 (3.4)	98 (3.9)	111 (4.4)	X X	X X	X X	X X
HC	mm (in)	5 (0.2)	134 (5.3)	135 (5.3)	160 (6.3)	199 (7.8)	X X	X X	X X	X X
HD	mm (in)	10 (0.4)	162 (6.4)	175 (6.9)	200 (7.9)	238 (9.4)	X X	X X	X X	X X
J	mm (in)		380 (15)	393 (15.5)	418 (16.5)	456 (18)	405 (16)	418 (16.5)	444 (17.5)	456 (18)
L	mm (in)	10 (0.4)	338 (13.3)	351 (13.8)	376 (14.8)	414 (16.3)	363 (14.3)	376 (14.8)	401 (15.8)	414 (16.3)
M	mm (in)	8 (0.3)	516 (20.3)	X X	X X	X X	516 (20.3)	X X	X X	X X
N	mm (in)	10 (0.4)	278 (11)	292 (11.5)	318 (12.5)	355 (14)	305 (12)	318 (12.5)	243 (13.5)	355 (14)

PROFILE Coaxial HPGe Photon Detector Product Configuration Guide

Streamline PROFILE FX Series Detector Dimensions

- Dimensions are for reference only and subject to change.
- If dimensional constraints are critical, contact the factory.

			Standard or LB			XLB		
Endcap Model (dia. mm)			-70	-83	-108	-70	-83	-108
Dim.	Unit	Tol.						
A	mm (in)	0.3 (0.01)	70 (2.75)	83 (3.25)	108 (4.25)	70 (2.75)	83 (3.25)	108 (4.25)
B	mm (in)	0.3 (0.01)	75 (2.95)	88 (3.45)	113 (4.45)	75 (2.95)	88 (3.45)	113 (4.45)
C	mm (in)	5 (0.2)	89 (3.5)	84 (3.3)	96 (3.8)	115 (4.5)	109 (4.3)	121 (4.8)
D	mm (in)	8 (0.3)	202 (7.9)	208 (8.2)	220 (8.7)	227 (8.9)	234 (9.2)	246 (9.7)
E	mm (in)	18 (0.7)	875 (34.4)	881 (34.7)	898 (35.4)	900 (35.4)	907 (35.7)	923 (36.4)
F	mm (in)	10 (0.4)	324 (12.8)	330 (13)	343 (13.5)	349 (13.8)	356 (14)	368 (14.5)
H	mm (in)	18 (0.7)	307 (12.1)	313 (12.3)	326 (12.9)	X X	X X	X X
HB	mm (in)	0.3 (0.1)	73 (2.9)	85 (3.3)	111 (4.36)	X X	X X	X X
HC	mm (in)	5 (0.2)	91 (3.6)	85 (3.3)	97 (3.8)	X X	X X	X X
HD	mm (in)	10 (0.4)	117 (4.9)	124 (4.9)	137 (5.4)	X X	X X	X X
J	mm (in)	10 (0.4)	336 (13.2)	342 (13.5)	355 (14)	361 (14.2)	367 (14.5)	380 (15)
L	mm (in)	10 (0.4)	293 (11.5)	300 (11.8)	312 (12.3)	319 (12.6)	325 (12.8)	338 (13.3)
N	mm (in)	10 (0.4)	234 (9.2)	240 (9.5)	253 (10)	259 (10.2)	266 (10.5)	279 (11)

PROFILE Coaxial HPGe Photon Detector Product Configuration Guide

Gamma Gage and Side-Looking Dewar Dimensions

- Dimensions are for reference only and subject to change.
- If dimensional constraints are critical, contact the factory.

			Cryostat/Dewar or Dewar Type								
			CFG-PG4 and DWR-x.xG			CFG-PMOD4 and DWR-MOD-xL		CFG-PS4, CFG-PD4, DWR-xxB and DWR-xxD			
			VOLUME			VOLUME		VOLUME			
Dim.	UNIT	TOL. ±	1.2L	3L	5L	3L	7L	7.5L	13L	30L	
Q	mm (in)	13 (0.5)	229 (9.0)	302 (11.9)	302 (11.9)	229 (9.0)	302 (11.9)	X X	X X	X X	
R	mm (in)	10 (0.4)	X X	X X	X X	X X	X X	174 (6.9)	174 (6.9)	155 (16.1)	
S	mm (in)	7.6 (0.3)	X X	X X	X X	X X	X X	77 (3.0)	77 (3.0)	60 (2.3)	
T	mm (in)	5 (0.2)	X X	X X	X X	X X	X X	10 (0.4)	10 (0.4)	13 (0.5)	
Y	mm (in)	5 (0.2)	157 (6.2)	229 (9.0)	229 (9.0)	157 (6.2)	229 (9.0)	224 (8.8)	307 (12.1)	442 (17.4)	
Z	mm (in)	5 (0.2)	229 (9.0)	267 (10.5)	419 (16.5)	292 (11.5)	320 (12.6)	452 (17.8)	429 (16.9)	610 (24.0)	

PROFILE Coaxial HPGe Photon Detector Product Configuration Guide

Example Model Numbers

Streamline Configuration

GEM-M5970	59 mm x 70 mm GEM-M detector with 70-mm diameter endcap.
CFG-GG-70	Portable Gamma Gage cryostat with matching 70-mm diameter flange.
DWR-1.2G	1.2 liter all-position dewar for Gamma Gage cryostat.
GEM-F8250-SMP	82 mm x 50 mm GEM-F detector with 95-mm diameter endcap and SMART-1 preamplifier and high voltage supply.
CFG-SD-95	Downlooking cryostat with matching 95-mm diameter flange.
DWR-7.5D	7.5 liter downlooking dewar for downlooking cryostat.
GEM-FX7025-HJ	70 mm x 25 mm GEM-FX detector with 83-mm diameter endcap and remote preamplifier and high voltage filter.
CFG-HJ-83	“J” configuration cryostat with remote fittings for the preamplifier and high voltage filter.
DWR-30B	30 liter side port dewar for “HJ” cryostat.
GEM-MX5970-LB-C-PL	59 mm x 70 mm GEM-MX detector with 70-mm diameter low-background carbon fiber endcap, and Plus preamplifier.
CFG-SV-70-LB	Vertical “dipstick” style cryostat with matching 70-mm endcap and low background charcoal pumping agent.
DWR-30	30 liter top port dewar that accepts “dipstick” style cryostats.

PopTop Configuration

GEM-MX5970P4	59 mm x 70 mm GEM-MX detector with 70-mm diameter endcap.
CFG-PG4-1.2	Portable Gamma Gage cryostat with 1.2 liter all-position dewar.
GEM-M8295P4-SMP	82 mm x 95 mm GEM-M detector with 95-mm diameter endcap and SMART-1 preamplifier and high voltage supply.
CFG-PD4-7.5	Downlooking cryostat with 7.5 liter dewar.
GEM-FX7025P4-HE	70 mm x 25 mm GEM-FX detector with 83-mm diameter carbon fiber endcap with sealed preamplifier and high voltage filter.
CFG-PG4-3	Portable Gamma Gage cryostat with 3 liter all-position dewar.
GEM-M7080P4-RB-SMP	70 mm x 80 mm GEM-M detector with 83-mm diameter reduced background carbon fiber endcap and SMART-1 preamplifier and high voltage supply.
CFG-PV4	Vertical “dipstick” style cryostat.
DWR-30	30 liter top port dewar that accepts “dipstick” style cryostats.

PROFILE Coaxial HPGe Photon Detector Product Configuration Guide

PROFILE Series GEM Detector Ordering Information

- For Streamline remove the "P4" from the model number.
- If dimensional considerations are critical, contact factory.
- Cryostat and dewar or other cooling device are not included with detector.
- Cryostat and dewar or other cooling device are required for operation.
- A cryostat must be ordered with a Streamline detector.
- GEM-M????P4 is an M-series PROFILE detector optimized for use with Marinelli Beakers: Choose the largest diameter which will fit within the Marinelli well.
- GEM-F????P4 is an F-series PROFILE detector optimized for "close geometry" samples such as filters, Petri dishes, and bottles. If possible, choose a crystal diameter >20% larger than your sample.
- Monte Carlo drawing included with GEM-F and GEM-M detectors.

Model No.	Crystal Dimension		Energy Resolution (FWHM)				Peak Shape		P:C Warr.	Nominal Relative Efficiency %	Endcap Dia. (mm)
	Actual Diameter (+0/-2 mm)	Actual Length Minimum	14.4 keV Warr. (eV)	46 keV Typical (eV)	@122 keV Warr. (eV)	@1.33 MeV Warr. (keV)	FW.1M/ FWHM Typical	FW.02M/ FWHM Typical			
GEM-M5970P4	59	70			900	1.8	1.90	2.65	62	38	70
GEM-F5930P4	59	30			675	1.8	1.90	2.65	40	20	70
GEM-M7080P4	70	80			950	1.9	2.00	3.00	75	66	83
GEM-F7040P4	70	40			750	1.9	1.90	2.65	50	40	83
GEM-M8295P4	82	95			1300	2.1	2.00	3.10	85	115	95
GEM-F8250P4	82	50			850	2.1	2.00	3.00	62	60	95
GEM-M94100P4	94	100			1300	2.3	2.00	3.10	90	175	108
GEM-FX5825P4	58	25	485	500	650	1.8	1.90	2.65	35	15	70
GEM-FX7025P4	70	25	575	575	650	1.9	1.95	2.75	40	20	83
GEM-FX8530P4	85	30	600	625	700	1.9	2.00	2.90	55	50	108
GEM-MX5970P4	59	70	800		900	1.8	1.90	2.65	62	38	70
GEM-MX7080P4	70	80	880		950	1.9	2.00	3.10	75	66	83
GEM-MX8295P4	82	95	1265		1300	2.1	2.00	3.10	85	115	95
GEM-MX94100P4	94	100	1280		1300	2.3	2.00	3.10	90	175	108

PROFILE Detector Options

- RB PopTop Only. Reduced background PopTop capsule with Carbon Fiber endcap, add "-RB" to the model number. Not compatible with -HE option.
- HE PopTop Only. Harsh Environment Option for PopTop detectors 76 mm and larger, add "-HE" to the model number. Not compatible with -RB option.
- PL PLUS Ultra-high-count-rate Preamp, add "-PL" to the model number. Not compatible with FX series or -HJ option.
- SMP SMART-1 detector option for positive bias detector, add "-SMP" to the model number. Not compatible with -HJ option.
- LB-C Streamline Only. Low-Background Detector with Carbon Fiber Endcap, add "-LB-C" to the model number. Requires selection of a Low-Background LB cryostat.
- XLB-C Streamline Only. Extra-Low-Background Detector with Carbon Fiber Endcap, add "-XLB-C" to the model number. Requires selection of a Low-Background XLB cryostat. Not compatible with -HJ option.
- HJ Streamline Only. Remote preamplifier and high voltage filter for use with HJ type cryostat, add "-HJ" to the model number. Requires selection of HJ cryostat. Not compatible with -PL, -SMP, or -XLB-C options.

Notes

¹FWHM = Full Width at Half Maximum; FW.1M = Full Width at One-Tenth Maximum; FW.02M = Full Width at One-Fiftieth Maximum; total system resolution for a source at 1000 counts/s measured in accordance with ANSI/IEEE Std. 325-1996, using ORTEC standard electronics.

²Measured at optimum shaping time using ORTEC analog or digital electronics.

³The proprietary contact employed in the FX- and MX-Series detectors offer exceptionally high transmission at energies below 40 keV. Some instability in transmission may occur below 20 keV if stored (uncooled) at room temperature for extended time periods (20–25°C or above). It is therefore recommended to keep FX- and MX-Series detectors cold, limiting the exposure to elevated ambient storage temperatures for applications which demand minimally varying efficiency below 20 keV.

PROFILE Coaxial HPGe Photon Detector Product Configuration Guide

PROFILE PopTop Cryostats and Dewars

• Dewar included except where marked *.

Model No.	Description
CFG-PD4-7.5	Down-looking Cryostat with 7.5-liter Dewar
CFG-PD4-13	Down-looking Cryostat with 13-liter Dewar
CFG-PD4-30	Down-looking Cryostat with 30-liter Dewar
CFG-PG4-1.2	Gamma Gage Cryostat with 1.2-liter Dewar (for 83 mm or smaller endcaps) (not compatible with -HE option)
CFG-PG4-3	Gamma Gage Cryostat with 3-liter Dewar
CFG-PG4-5	Gamma Gage Cryostat with 5-liter Dewar
CFG-PH4	Horizontal Cryostat (Dipstick type). Includes LNTC1.5WH. Dewar not included.* Choose DWR-30 or DWR-30-OP.
CFG-PMOD4-3	Gamma Gage Cryostat with 3-liter Multi-Orientation Dewar
CFG-PMOD4-7	Gamma Gage Cryostat with 7-liter Multi-Orientation Dewar
CFG-PS4-7.5	Side-Looking Cryostat with 7.5-liter Dewar
CFG-PS4-13	Side-Looking Cryostat with 13-liter Dewar
CFG-PS4-30	Side-Looking Cryostat with 30-liter Dewar
CFG-PSHP4	Down-Looking Shallow-Hole Probe with 0.7-liter Dewar
CFG-PV4	Vertical Cryostat (Dipstick type). Includes LNTC1.5WH. Dewar not included.* Choose DWR-30 or DWR-30-OP.
DWR-30	30-liter Dewar
DWR-30-OP	30-liter Offset-Port Dewar
DWR-S/F	Storage Fill Dewar for CFG-PG4-X
CFG-X-COOL-III-115	X-COOLER III with PopTop connector using 110-120 V ac, 60 Hz Input Power
CFG-X-COOL-III-230	X-COOLER III with PopTop connector using 220-240 V ac, 50 Hz Input Power

PROFILE Coaxial HPGe Photon Detector Product Configuration Guide

PROFILE Streamline Cryostats

- Select dewar from PROFILE Streamline Dewars. Dewar included except where marked*.
- Append matching Detector Endcap Size designation to cryostat model: -70, -83, -95, -108 [e.g., CFG-SJ-95 for GEM-F8250 or CFG-SL-XLB-83 for GEM-FX7025-XLB-C]

Model No.	Description
CFG-GG	Gamma Gage Cryostat Dewar
CFG-HJ	J-type Cryostat with Remote Preamp and Dewar. (For -HJ option only.)
CFG-SD	Down-Looking Cryostat with Dewar
CFG-SH	Horizontal Cryostat (Dipstick type). Includes LNNTC1.25WH. Dewar not included.*
CFG-SJ	J-type Cryostat with Dewar
CFG-SL	Side-Looking Cryostat with Dewar
CFG-SV	Vertical Cryostat (Dipstick type). Includes LNNTC1.25WH. Dewar not included.*

LOW-BACKGROUND

CFG-GG-LB	Low-Background Gamma Gage Cryostat with Dewar
CFG-HJ-LB	Low-Background J-type Cryostat with Remote Preamp and Dewar. (For -HJ option only.)
CFG-SD-LB	Low-Background Down-Looking Cryostat with Dewar
CFG-SH-LB	Low-Background Horizontal Cryostat (Dipstick type). Includes LNNTC1.25WH. Dewar not included.*
CFG-SJ-LB	Low-Background J-type Cryostat with Dewar
CFG-SL-LB	Low-Background Side-Looking Cryostat with Dewar
CFG-SV-LB	Low-Background Vertical Cryostat (Dipstick type). Includes LNNTC1.25WH. Dewar not included.*
CFG-SD-XLB	Extra-Low-Background Down-Looking Cryostat with Dewar
CFG-SH-XLB	Extra-Low-Background Horizontal Cryostat (Dipstick type). Includes LNNTC1.25WH. Dewar not included.*
CFG-SJ-XLB	Extra-Low-Background J-type Cryostat with Dewar
CFG-SL-XLB	Extra-Low-Background Side-Looking Cryostat with Dewar
CFG-SV-XLB	Extra-Low-Background Vertical Cryostat (Dipstick type). Includes LNNTC1.25WH. Dewar not included.*

PROFILE Streamline Dewars

For Cryostat	Choose	Description	
CFG-GG	DWR-1.2G	1.2-liter All-Orientation Dewar	Included with Cryostat
	DWR-3.0G	3.0-liter All-Orientation Dewar	Included with Cryostat
	DWR-5.0G	5.0-liter All-Orientation Dewar	Included with Cryostat
	DWR-MOD-3L	3-liter Multi-Orientation Dewar	Included with Cryostat
	DWR-MOD-7L	7-liter Multi-Orientation Dewar	Included with Cryostat
	DWR-0.7-SHP-1	0.7-liter Shallow-Hole Probe Dewar	Included with Cryostat
	DWR-S/F	Storage/Fill Dewar for DWR-XG	
CFG-HJ, SJ, SL	DWR-7.5B	7.5-liter Side-Looking Dewar	Included with Cryostat
	DWR-13B	13-liter Side-Looking Dewar	Included with Cryostat
	DWR-30B	30-liter Side-Looking Dewar	Included with Cryostat
CFG-SD	DWR-7.5D	7.5-liter Down-Looking Dewar	Included with Cryostat
	DWR-13D	13-liter Down-Looking Dewar	Included with Cryostat
	DWR-30D	30-liter Down-Looking Dewar	Included with Cryostat
CFG-SV, SH	DWR-30-OP	30-liter Offset-Port Dewar	
	DWR-30	30-liter Dewar	

HTDS Parc d'Activités du Moulin de Massy –3 rue du Saule Trapu

BP246 - 91882 Massy Cedex France

Tél : 01 64 86 28 28 Fax : 01 69 07 69 54 info@htds.fr

Pour une plus grande proximité avec nos clients et une réactivité optimale,

HTDS dispose de filiales dans 6 pays :

HTDS Algérie : +213 219 163 73

HTDS Égypte : +202 229 053 06

HTDS Jordanie : +962 651 561 12

HTDS Libye : +218 923 044 874

HTDS Maroc : +212 222 749 59

HTDS Tunisie : +216 770 836 961