

ORTEC®

ISOTOPIC

A Practical, Flexible, and Defendable Solution for
Gamma Spectrometry Waste Assay Measurements

WHAT'S NEW!

Windows 7/64-bit Compatible,
Expanded Counting Geometries,
Extensive Reporting Tools,
Command Line Operation

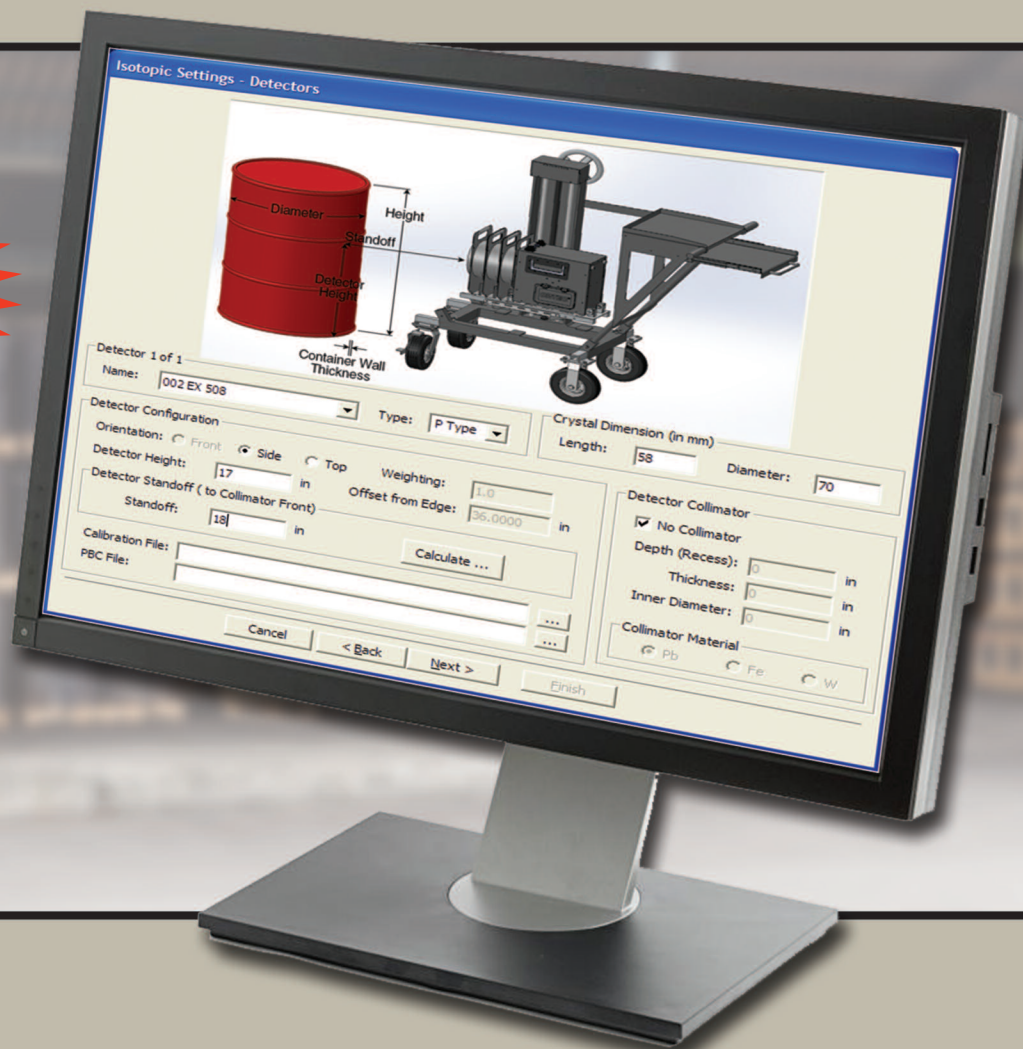

AMETEK®
ADVANCED MEASUREMENT TECHNOLOGY

ISOTOPIC provides an integrated, practical solution to a wide range of gamma-ray measurement problems encountered in radioactive waste assay and characterization applications. High resolution, high purity germanium (HPGe) spectra are analyzed and assay results determined for large-scale bulk samples.

ISOTOPIC can be used “out of the box” as part of a simple to operate mobile system, such as an ORTEC ISO-CART-85 or it can be integrated into an automated system, for example, for high throughput measurements of large containers in decommissioning projects.

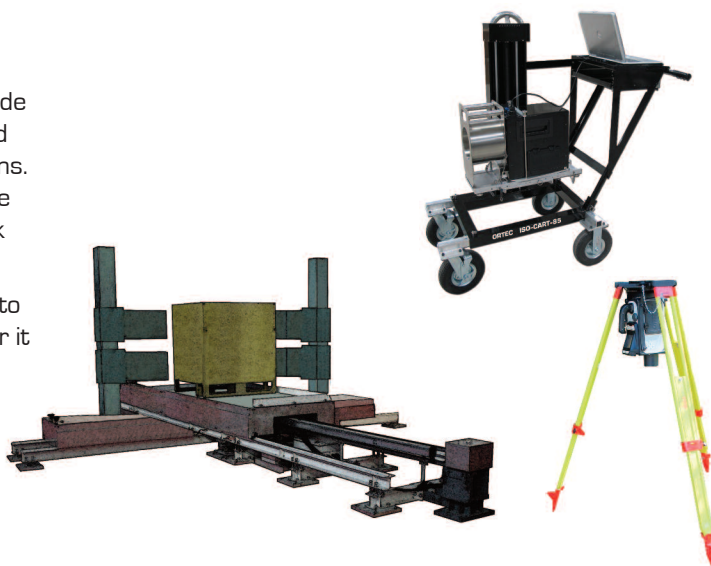

Why ISOTOPIC?

Practical

- Practical, easy-to-use solution to quantitative assay of gamma-emitting waste samples in a variety of configurations.
- Ideal for applications using existing ORTEC ISO-CART-II, especially in combination with ORTEC IDM-200-V integrated HPGe detectors (ISO-CART-85 assay systems).
- Supports additional HPGe detectors and electronics or as part of an integrated measurement system.
- Calibrate ANY detector on site, TRACEABLY, in minutes.
- Easy system expansion.

Flexible

- Analyzes all types of gamma-emitting waste, fissile and non-fissile.
- Measures various container shapes and sizes, surfaces and even soils using independently verified analysis methods.
- CLOSE geometry measurements for “on-endcap” applications such as bottle counting.
- Easily combine multiple measurements on a single object.
- Expanded Report Writer with MS Access Data Storage and Crystal Reports for Custom Reports.
- Supports software integration into large, automated measurement systems.

Defendable

- Robust algorithms developed and refined by multiple US DOE sites as well as the US Energy Measurements Laboratory.
- Third party “round-robin” testing to validate results accuracy.
- Results traceability guaranteed via simple user- or factory-calibration with traceable source.

¹Hagenauer, R.C., "Nondestructive Assay Quantification of Poorly Characterized Radioactive Isotopes," Proceedings of the 4th Nondestructive Assay and Nondestructive Waste Characterization Conference, Salt Lake City, 1995.

²H.L. Beck, et al., "In Situ Ge(Li) and NaI(Tl) Gamma Ray Spectrometry," U.S. Dept. of Energy, Environmental Measurements Laboratory, HASL-258, September (1972).

³I.K. Helfer and K.M. Miller, "Calibration Factors for Ge Detectors Used for Field Spectrometry," Health Physics, Vol. 55, No. 1, pp 15–29 (1988).

⁴NPL Nuclear Industry Proficiency Test Exercise 2012. NPL Report IR 30 2013 (UK National Physical Laboratory). ORTEC system was participant number 9. Report may be downloaded at <http://www.ortec-online.com/download/NPL-Report-IR30.pdf>.

⁵For use in M-1 mode for soil characterization, an HPGe with crystal length/diameter in the range of 0.5 to 1.3 is recommended. 80% of HPGe detectors meet this criterion. The ORTEC PROFILE M Series detectors are ideal for this and the ISOTOPIC container measurements.

Applicability

The following geometries are easily accommodated:

- γ Boxes, Drums, Pipes or Surfaces (collimated detector)
- γ Close Geometry small containers (e.g. bottles on-endcap)
- γ Wide Area Assay of Soils and Surface (uncollimated detector: M-1 methodology)

ISOTOPIC provides a number of standard geometry "templates" from which a specific measurement configuration may be developed. These include cylinders (from top and side; including lined cylinders (pipes)), boxes, point source (far field), close geometry small containers on-endcap, and infinite plane. The bottle counting option on the ISO-CART-85 is an example of an "on-endcap" close geometry. The infinite plane (soils) mode provides uncollimated measurement of contamination, fall out or wide area spills, either washed into or on top of an infinite plane surface, most typically soil on the ground.

Pre-defined Configurations and Analysis Defaults

The image displays several overlapping windows from the ISOTOPIC software interface:

- Isotopic Settings - Detectors:** Shows a 3D model of a red drum with labels for Diameter, Height, Standoff, and Detector Height. Below the model are fields for Name, Type, Length, and Crystal Dimension.
- Operator Permissions:** A list of checkboxes for various permissions, all of which are checked:
 - Allow Energy Recalibrations:
 - Allow Background QA Tests:
 - Allow Sample QA Tests:
 - Allow Configuration Selection:
 - Allow Modification of Configuration Parameters:
 - Allow Isotope Plot:
 - Allow MCB Settings Modifications:
 - Allow Recall Files Command:
 - Allow Recall Scan Command:
- Isotopic Settings - Analysis:** Contains sections for:
 - Analysis:** Library, Peak Search Sensitivity, Match Width, Background Points, Activity and Quantity Units, Additional Error, Results from Multiple Detectors.
 - Reporting Options:** Library Peaks, Library Peak Matrix, Unknown Peaks, Error Estimation, MCA's and Correction Factors, Spectrum and Interactive Plots, Print on completion.
 - Uncertainty Reporting:** Percent, Counting, Confidence Level.
 - Isotopic Interactive Plot:** No of Most Interest Peaks per Nuclide to Plot.
- Isotopic Settings - Analysis (second instance):** Shows a 3D model of a brown box with labels for Length, Top, Height, Side, Depth, Offset, Standoff, Detector Height, and Container Wall. Below are fields for Name, Type, Length, Diameter, and Crystal Dimension.
- Isotopic Settings - Detectors (second instance):** Shows a 3D model of a detector cart with a detector head. Below are fields for Name, Type, Length, Diameter, and Crystal Dimension.

Methodology

In container mode, for the counting of packages, pipes and surfaces, the detector is characterized by a single point-source measurement, even when a collimator is to be used. This primary calibration, which can be traced to a certified standard, for any detector, is extrapolated or modeled to match the physical situation of the sample; container geometry, material, and matrix composition. The model is based on "point-kernel" methods in which the entire measurement problem is broken down into multiple source/matrix voxels and their contribution to the composite spectrum are calculated and summed. The approach, which is similar to Monte-Carlo Methods, utilizes detector parameters (crystal diameter, crystal length, dead layer, and end cap thickness) which the user supplies as part of the measurement configuration. No special separate measurements are needed to characterize the detector other than one point-source calibration.

ISOTOPIC includes improved algorithms for "close geometry" where the detector to container distance is less than 15 cm.

For the uncollimated wide-area counting of soils, the "1-meter" methodology developed by the US DOE EML² and later extended³ is used. It is applicable in many situations:

- γ Decontamination assessment of previously used sites
- γ Assessment of nuclides deposited during emergencies
- γ Routine environmental monitoring near nuclear facilities

The EML methodology reduces a complex measurement problem to the product of three, simply-determined factors. The gamma-ray peak areas are related to the nuclide-specific activity by the product of the three factors. These factors have been determined for a range of detector types and soil conditions and are tabulated within the program. The efficiency calibration is determined using the stated efficiency according to the usual ANSI/IEEE 325-1996 convention at 1.33 MeV, and from the crystal length and diameter.

For improved accuracy at low energy, the user can use the same calibration used for container mode as an alternate to the EML method.

No special (and costly) Monte-Carlo characterizations of the detector are necessary. The attenuation correction is determined by selection of the soil type and type of nuclide distribution: recent (surface) deposits, older (washed-in) deposits or natural (uniform) deposits. The energy and peak shape calibration are performed using any multilene source and may be entirely automated. However you plan to use ISOTOPIC, there will be no unexpected detector calibration costs.

Wizard-Based, Point Source, TRACEABLE Calibration Process

Energy Calibration Fit
 $Energy = -5.8856 \times 10^{-5} Channel + 5.61359 \times 10^{-8} Channel^2$
 $FWHM (ch) = 4.3964 \times 10^{-4} Channel + 2.70116 \times 10^{-6} Channel^2$

Energy/FWHM Table

Channel Energy (keV)	Fit (keV)	Delta	FWHM	Fit	Delta
0.00	186.10	-5.89103 16%	1.39	1.19	14.25%
0.00	238.62	-5.89102 47%	1.46	1.19	18.11%
0.00	241.91	-5.89102 43%	1.46	1.19	18.22%
0.00	295.17	-5.89101 99%	1.49	1.19	20.06%
0.00	328.60	-5.89101 74%	1.55	1.19	35.47%
0.00	351.90	-5.89101 67%	1.61	1.19	25.88%
0.00	563.17	-5.89101 61%	1.93	1.19	38.19%
0.00	609.30	-5.89100 97%	1.89	1.19	26.71%
0.00	768.60	-5.89100 97%	2.07	1.19	42.23%
0.00	806.10	-5.89100 93%	1.96	1.19	29.10%
0.00	911.10	-5.89100 65%	2.42	1.19	50.66%
0.00	934.10	-5.89100 63%	2.64	1.19	54.76%
0.00	1120.00	-5.89100 53%	2.63	1.19	54.58%
0.00	1460.70	-5.89100 40%	3.05	1.19	60.80%
0.00	1764.50	-5.89100 33%	3.59	1.19	66.70%

Efficiency Calibration Fit
 $Efficiency = 6.2962 \times 10^{-4} \ln(E) + 0.405507 \times 10^{-4} \ln(E)^2 + 0.0742773 \times 10^{-4} \ln(E)^3$
 $Efficiency = -14.5763 \times 10^{-4} \ln(E) + 0.47592 \times 10^{-4} \ln(E)^2$

Efficiency Table

Energy	Efficiency	Fit	Delta
59.54	3.1557E-003	3.1448E-003	0.35%
68.03	3.1949E-003	3.1797E-003	-1.33%
122.07	2.9190E-003	2.8651E-003	1.85%
150.00	*****	*****	*****
165.94	2.3576E-003	2.4285E-003	-3.43%
390.90	1.7965E-003	1.7052E-003	5.80%
661.62	1.4486E-003	1.2968E-003	10.48%
890.02	1.0800E-003	1.0856E-003	-0.52%
1173.23	8.0346E-004	9.1846E-004	-14.34%
1332.51	7.2573E-004	8.4527E-004	-16.47%
1636.01	7.9785E-004	6.7818E-004	16.00%

Multiple Measurements of a Single Container

In the measurement of any large container of waste, several measurements are usually made from different directions to ensure the best results are obtained. This will be done sequentially if only one hardware system is available or simultaneously if there is access to multiple sets of hardware. ISOTOPIC can automatically combine the results taken either way by a user-defined weighted average. When multiple detectors are used at the same time, live spectra may be displayed on screen simultaneously from each detector, increasing user confidence.

Standard and Custom Reporting

ISOTOPIC provides flexibility in reporting within the standard product. All changeable parameters may be included in the standard output report. Analysis results are stored in an MS Access compatible database, from which they are easily printed or exported for further processing into summary reports. Fully customized reports may be generated through the use of Crystal Reports.

Hardware Compatibility

ISOTOPIC like all ORTEC CONNECTIONS Applications software products, is compatible with all ORTEC MCA hardware. In particular, it is ideal for use in conjunction with the IDM-200-V, a complete rugged and portable HPGe spectrometer system which does NOT require the use of liquid nitrogen.

Support for Systems Integrators

Systems integrators often need to be able to develop automated systems in which the details of hardware control and analysis are largely concealed from a human operator under a software layer which provides a greatly simplified user interface and/or allows unattended operation. Extensive documentation is provided in the standard user documentation set explaining how the analysis engine may be controlled from a command line along with example material. Analysis parameters and analysis results are saved to an ACCESS compatible database. All necessary file structure information is provided, including the ISOTOPIC database file structures. The spectrum or "SPC" file structures are provided in a separate accompanying manual.

ORTEC hardware control is achieved through the so called UMCBI which provides a common API to all supported spectroscopy hardware. A programmer's toolkit is available as an option to provide instruction to the systems integrator as to how to easily achieve MCA hardware control from his/her own developed program. Often, the basic ISOTOPIC program is used to set up the system hardware and calibration, and then the system is controlled by the integrator's application for the routine cycle of operations. With these tools and the level of documentation provided, system integrators can easily develop sophisticated measurement systems.



ISOTOPIC In Use

ISOTOPIC has two modes: supervisor and operator. The operator need make choices only from the minimum subset of system options defined by the supervisor. The supervisor mode defines what operations the operator is allowed to carry out. A wizard guides the supervisor through the process of setting up the operator procedures. The wizard presents the parameters on logically grouped screens, with an emphasis on clarity of approach.

The supervisor/operator partitioning means that even semi-skilled operators in the field will collect good data with less wasted time for repeats (lower cost per measured item). Of course a skilled user may choose to run both modes.

Supervisor calibrates the system, creates libraries, defines sample geometries, matrices, collimators to be used, and other functions for later use by the operator. Supervisor can also define which features operator may access.

The operator main screen, which is customized by the permissions granted by the supervisor, is much simpler than the supervisor screen. In routine use, for container analysis, the operator need only start the acquisition, select the configuration (nearest standard container configuration), and enter the "book keeping data" such as container ID, type, weight, and the critical measurement data, such as detector-to-container distance.

The standard container configurations and collimator configurations are defined and specified by the supervisor. A container configuration includes the default dimensions, materials, and matrix detail. Any number of these configurations may be specified and recalled by the operator when needed.

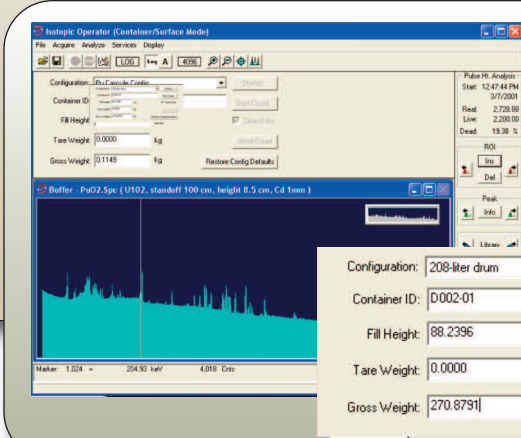

The screenshot displays the ISOTOPIC Operator interface. The main window shows a configuration panel on the left with fields for Container ID, Fill Height, Tare Weight, and Gross Weight. Below this is a real-time data acquisition plot showing a spectrum. A configuration dialog box is overlaid on the bottom right, allowing the operator to select a configuration (e.g., '208-liter drum'), enter a Container ID ('D002-01'), and input Fill Height (88.2396 cm), Tare Weight (0.0000 kg), and Gross Weight (270.8791 kg). The dialog includes buttons for 'Startup...', 'Start Count...', 'Clear Data', 'Abort Count', and 'Restore Config Defaults'.

Simple OPERATOR MODE GUI: Controls Hardware with Minimal Data Entry

Analysis Tools

Interactive Results Plot

When the analysis is complete, the operator can adjust the container/matrix physical parameters (such as matrix density or container wall thickness) to optimize the results by use of the nuclide plot.

The plot shows the percentage difference between the corrected measured activity and the activity calculated for the reference peak for each nuclide. The supervisor selects the reference peak. The operator may optimize the analysis, adjusting the container, matrix, and weight fraction uranium, to refine the results. The visual evidence of a good result is immediately seen when the points from a multi-peaked nuclide are distributed normally about the "zero-line." In the case of uranium analysis, if the U-235 enrichment is known, it may be entered and then the U-238 and U-234 values are computed more accurately for samples containing weak uranium activity. Homogeneous and inhomogeneous samples are analyzed with increased accuracy by this method. A good indication that a package contains an inhomogeneous distribution of materials is that the user can obtain a combination of parameters which makes the activity plot flat for some nuclides but not others. This plot can form part of the output report, along with a plot of the spectrum itself.

Field of View Calculator

The detector field of view is an important parameter in the measurement. The software algorithm "corrects" or adjusts from what is "seen" in the field of view of the collimator to an assay of the contents of the whole container. In general, the field of view is chosen so that it is filled by container, further back from this will reduce signal to noise in the spectrum, nearer than this makes the measurement more susceptible to localized inhomogeneities (the effects of which can be further minimized by making multiple measurements in different orientations). A convenient field of view calculator allows the operator to assess what portion of the container is actually within the field of view of the collimated detector.

Useful Analysis Tools

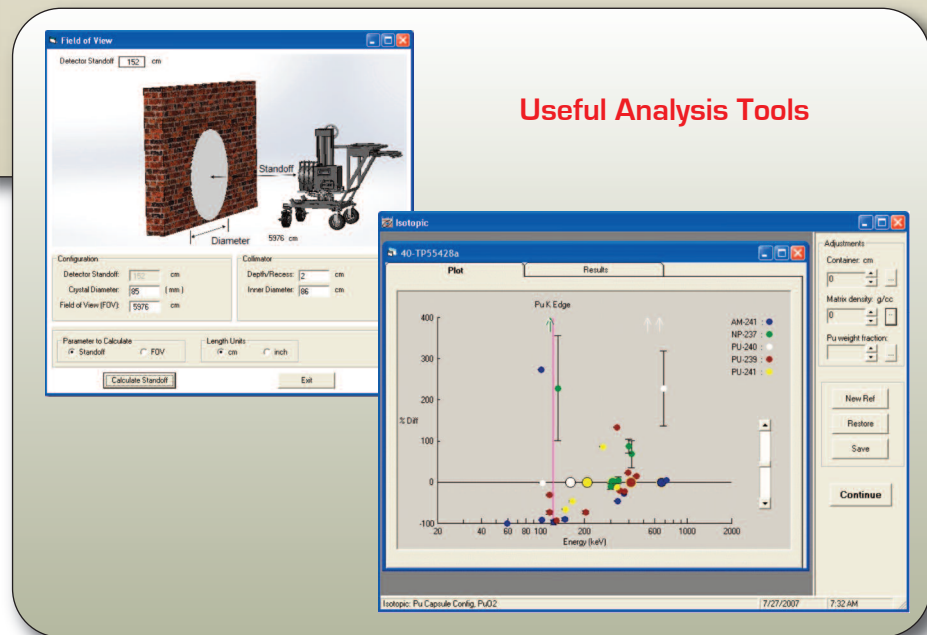

Reports

When the fine-tuning is finished, the operator selects a report for each nuclide showing the activity and weight. These results may then be printed and archived. The report files are written in either a database summary or as complete reports showing all input and correction information. Custom reports may be generated by the use of the report generator option. The tabulated components of error estimates can be used to help reduce overall uncertainties, for example, by extending count time or repositioning the detector. The user is also warned if any of the corrections appear to be excessively large. Minimum Detectable Activities (MDA) are calculated for each nuclide. Activities, grams of U or Pu, or MDAs from multiple measurements may be reported as weighted averages. The weighting is user definable.

The screenshot displays the 'Isotopic Settings - Analysis' window with various configuration options for uncertainty reporting, reporting options, and isotopic interactive plots. To the right, a sample 'Isotopic Averaged Report' is shown, detailing general information, configuration, isotopic results, and uranium analysis.

Comprehensive and Custom Reporting

Isotopic Averaged Report

General Information

Isotopic-Average MDA, NBS 446-TopView 12 inches
 NBS 446-TopView 12 inches
 NBS 446-TopView 12 inches Buf00086-uTSP 7390.html
 NBS 446-TopView 12 inches Buf00086-MT7390.html

Data analysis: 4/18/2014 4:48:58PM
 Tolerance (FWHM): 0.50

Configuration

Material ID: Al
 Fill Height: 1.58 cm
 Depth: 0.00
 Container Density: 2.70 g/cc
 Density(initial): 3.400 g/cc
 Pu Int. Fraction: 0.0000
 Gross Wt.: 2.987E+001 kg
 Density (measured): 3.399 g/cc
 Thickness (entered): 0.20 cm
 Length: N/A
 Thickness: 1.58 cm
 Net Wt.: 2.987E+001 kg

Isotopic Results

Nuclide	Mass(g)	Activity(uCi)	Uncertainty (%)	MDA (g)	MDA (uCi)
U-235	3.750E+000	8.11E+000	10.94	1.55E-002	3.36E-002
U-238	8.553E+001	2.85E+001	8.19	5.34E-001	1.78E-001
U-234	0.000E+000	0.00E+000	39.87	1.51E-002	9.46E+001
Np-237	0.000E+000	0.00E+000	27.94	1.81E-005	1.28E-002
Total Activity:		3.659E+001 uCi	Total Alpha Activity: 3.66E+001 uCi		

Uranium Analysis

Total grams of Uranium: 8.928E+001
 U-235 enrichment in % (186 to 1001-kev region): 2.475 +/- 0.080
 Ratio U-238/U-235: 137.37

Averaged MDA for the Measured Geometry

Nuclide	Gamma Ray (keV)	MDA (grams)	MDA (uCi)
U-235	185.85	1.55E-002	3.36E-002
U-238	1.00145	5.34E-001	1.78E-001
U-234	120.91	1.51E-002	9.46E+001
Np-237	312.10	1.81E-005	1.28E-002

Analyzed By: _____
 Approved By: _____

Accuracy of Results

The underlying assumption for a single measurement is that the entire object contains the same matrix and specific activities as the sub-volume which is under measurement. Inaccuracies due to this assumption being incorrect may be reduced by making multiple measurements from different points on the surface of the object and comparing similarities. These comparisons may be used to develop measurement strategies for an individual object, thereby reducing such systematic errors. ISOTOPIC can provide weighted average reports including the relevant minimum detectable activities, if required.

Overall, the major influencers of the accuracy of the achievable results are: statistics and counting time, calibration uncertainty, and the number of replicate measurements carried out on a single object (random uncertainties), inhomogeneity of matrix density and nuclide distribution, and the number of measurements carried out on a single object from different directions (systematic errors).

A range of 10 to 50% accuracy should be considered representative, the smaller being for well-defined geometries in homogeneous and light matrices.

Analysis Library Manager

ISOTOPIC includes a comprehensive library editor for building custom analysis libraries. The editor allows the operator to cut and paste nuclides and peaks from master libraries, add flags to individual peaks for identification (single escape peak, x-ray, or other) and analysis (key line or exclude from activity calculation), and save the library as any name. It also includes full integration of the Nuclide Navigator library tool. ISOTOPIC will use Nuclide Navigator if installed, and can read Nuclide Navigator libraries in Microsoft Access Database format (no conversion necessary), and save libraries in database format for use by Nuclide Navigator.

Quality Assurance

ISOTOPIC quality assurance complies with the demands of ANSI N13.30. For each detector the following are monitored:

- Total detector background
- Total (decay corrected) activity for all calibration nuclides
- Average FWHM ratio (spectrum to calibration standard)
- Average FW1/10M ratio (spectrum to calibration standard)
- Average peak shift from library values
- Actual peak centroid energies

Calculational Details

Summary of the ISOTOPIC Mode Methodology for Containers

The activity of an isotope in a container is given by:

$$A_{isotope} = \frac{PA_{meas} (CF_{item})(CF_{col})}{BR_{\gamma ray} (\epsilon_{det})} \quad \text{where}$$

$A_{isotope}$ = activity of the isotope to be reported (Bq/ μ Ci).

PA_{meas} = measured peak area count rate for a reference gamma ray of the isotope (c/s). This quantity is determined directly from the spectrum and the acquisition Live Time. If short half life isotopes are present or if sample activities in a flowing sample are varying rapidly, the ORTEC patented ZDT dead-time correction algorithm may prove beneficial

CF_{item} = container, matrix, and sample self-attenuation correction factors. ISOTOPIC calculates these based on the physical data supplied in the configuration.

CF_{col} = collimator correction factor. Some gamma rays will penetrate any collimator surrounding the germanium detector. The collimator correction factor is heavily dependant on the diameter of the collimator, the depth of collimation, and the wall thickness of the collimator, as well as the angle of the radiation and its energy .

The collimator correction factor is determined by computing the fraction of the activity that is not shadowed by the collimator and then computing the penetration length through the collimator for the remaining activity. This is determined for each voxel of the item being measured.

If no collimator is present this is set = 1.

$BR_{\gamma ray}$ = gamma-ray branching ratio. This information is contained in the nuclide library.

ϵ_{det} = detector efficiency measured using a NIST-traceable point source (cps per Bq, μ Ci). A typical calibration distance is 30 cm, at which detector and source may be regarded like point objects. At close distances the detector length and diameter dimensions become significant. These dimensions are provided during the calibration process, and the correction to the simple "point detector" assumption is applied automatically. The close geometry correction is described in the ISOTOPIC supervisor manual¹.

ISOTOPIC

When gram quantities, $Mass_{isotope}$, of reported isotopes are needed, these are given by:

$$N = \frac{A_{isotope}}{\lambda_{isotope}} \quad Mass_{isotope} = \frac{N(At)}{Av}$$

where

- N = number of atoms of a reported isotope.
- $\lambda_{isotope}$ = decay constant of a reported isotope (sec^{-1}).
- At = atomic number of the measured isotope (g/Av).
- Av = Avogadro's number.

Result Averaging of Multiple Measurements

When results of multiple measurements are combined, a weighted average is calculated according to:

$$A_{average} = \frac{\sum A_i w_i}{\sum w_i}$$

where

- A_i = individual activity (gram or MDA) results.
- w_i = user-defined weighting factors.

Methodology for Soils

The specific activity, A (Bq/m^2 or Bq/g) is related to the net peak count rate N_f by:

$$A (\text{activity}) = \frac{N_f (\text{net peak count rate})}{\left(\frac{N_f}{N_0}\right) \left(\frac{N_0}{\Phi}\right) \left(\frac{\Phi}{A}\right)}$$

where

- N_f/N_0 = angular correction factor of the detector at that energy for a given source distribution in the soil.
- N_0/Φ = peak count rate per unit uncollided flux for a parallel beam of gamma rays of the peak energy that is incident normal to the detector face ($\text{cpm}/\gamma \text{ s}^{-1}$).
- Φ/A = total uncollided flux at the peak energy arriving at the detector per unit inventory or concentration of the nuclide in the soil ($\gamma \text{ cm}^{-2} \text{ s}^{-1}$) or ($\gamma \text{ g}^{-1} \text{ s}^{-1}$).

The method of estimating calibration factors uses information about the detector and the distribution(s) of radionuclides being measured:

- Detector Efficiency (expressed as %)
- Detector Orientation (up or down)
- Detector Aspect Ratio (calculated as crystal length/crystal diameter)
- Deposition Profile Parameter α/ρ value(s)]

α/ρ is assumed to be 0 (for uniform distribution) for all natural emitters. α/ρ is assumed to be infinite (for surface only distribution) for fallout on undisturbed soil.

Beck's method is implemented in ISOTOPIC by calculating values for each of the calibration parameters. The calculation is carried out for each gamma ray of all the nuclides identified.

ISOTOPIC Specifications

General

The acquisition control and quantitative analysis functions are integrated into a concise package for use in PC-based *in situ* gamma spectroscopy systems for the determination of radioactive content of containers, objects, surfaces, and soils.

Operating System

Windows 7 64-bit hardware compatibility is available for all ORTEC instruments that use USB and TCP/IP connectivity. These instruments, as well as other legacy hardware, are also supported with Windows 7 and XP 32-bit operating systems.

Spectroscopy Hardware Support

ISOTOPIC is recommended for use with the ORTEC IDM-V-200 Integrated HPGe Spectrometer. However, all ORTEC MCBs (past and present) and all other devices supported by ORTEC CONNECTIONS are compatible. Support is built-in for advanced operations (where provided in hardware): amplifier gain/shaping control, Auto-PZ, "optimize" and InSight™ mode, digiDART field mode, graphical setting of MCB spectrum stabilizer and statistical uncertainty peaks. Specifically, the IDM-200-V is recommended for *in situ* measurements.

File Formats Supported

ORTEC .SPC and .CHN, and ASCII ".SPE" are supported as standard in file save, recall, and compare functions. Other file formats may be imported by the use of A49-B32 Data Master.

Quantitative Spectrum Analysis Methods

Peak Search

Peak Search by library direction for specified nuclides, plus Mariscotti peak search for non-specified nuclides, both main library and supplemental ("suspect") library are used.

Interactive Bulk Sample Parameter Adjustments

Interactive Matrix and container adjustments and automatic attenuation correction for new matrix. Easy to use graphical display of relative analysis results to show the best matrix.

Deconvolution Method

Both peak finder and library are used to direct the deconvolution process. Automatic recalibration of Energy/channel based on identified peaks where possible.

Choice of Detection Limit Formalisms

- | | |
|--|-------------------------------|
| • ORTEC Traditional | • Peak Area |
| • ORTEC Critical Level | • Air Monitor — Gimrad method |
| • No MDA (report zeros if less than MDA) | • Reg. Guide 4.16 Method |
| • KTA Rule | • Counting Lab — USA |
| • Detection Limit 2 sigma — Japan | • DIN 25 482.5 |
| • Detection Limit 3 sigma — Japan | • Erkennungsgrenze |
| • Currie Limit | • DIN 25 482.5 |
| • RISO MDA | • Nachweisgrenze |
| • ORTEC LLD | • GTN5/CEA/EDF (France) |
| | • Nureg 0472 |

Decay Corrections

- Decay correct to any date/time, either back or forward

Spectral Corrections

- Peaked Background Correction
- Random summing (high-rate counting losses)
- Library-based peak interference correction

Reporting

Choose any ORTEC Standard report option:

- Direct to printer
- Automatically written to database
- Crystal Report formatted output
- Report in HTML format. From there it can be saved as a disk file.

Calibration

Energy Calibration

- Multipoint, quadratic for energy and FWHM
- Automatic Energy Calibration (Patent No. 6,006,162)

Semi-Empirical Efficiency Calibration Fit Options:

ISOTOPIC Mode

A point source calibration is established via one of the following methods:

- Single Function Polynomial (x-Point)
- Interpolative above and below "knee"
- Quadratic above or below user-set "knee"
- Linear above or below user-set "knee"

The point source calibration is extrapolated to the physical geometry-matrix situation via point-source Kernel calculations internal to the program.

Infinite Plane Mode (for Soils and Surfaces: Uncollimated Detector)

The Beck² 1-meter methodology, with extension to large detector sizes³, as used by US DOE Environmental Measurements Laboratory (EML). The EML methodology is used to produce an efficiency curve based on detector dimensions and IEEE efficiency value. The soil density and attenuation is specified in user-editable alpha/rho files.

Soil Attenuation Factors

In soil, attenuation depends on the soil thickness and density, which is modeled by the parameter α/ρ (where α is the reciprocal of the relaxation length, defined to be the soil thickness required to reduce the flux at a particular energy by a factor of e , and ρ is the soil density in gm/cc). For a surface distribution α/ρ is infinite, while for uniform (natural emitters) distribution, α/ρ is 0. Values of α/ρ ranging from 0.05 to 0.5 have been found to describe realistic fallout distributions accurately, the more aged fallout being represented by the smaller α/ρ values.

The α/ρ values are nuclide-specific and are stored in a table which may be edited by the user to reflect the measurement conditions.

ISOTOPIC

Ordering Information

Model	Description
ISOPLUS-BW	ISOTOPIC Advanced Gamma-Ray Waste Assay Analysis Software
ISOPLUS-GW	Documentation for ISOTOPIC
ISOPLUS-NW	ISOTOPIC Network Copies
ISOPLUS-UW	Update to ISOTOPIC
ISOPLUS-2YW	2 year update subscription for ISOTOPIC
ISOPLUS-3YW	3 year update subscription for ISOTOPIC
ISOPLUS-4YW	4 year update subscription for ISOTOPIC
ISOPLUS-5YW	5 year update subscription for ISOTOPIC

Specifications subject to change
071514

ORTEC[®]

www.ortec-online.com

Tel. (865) 482-4411 • Fax (865) 483-0396 • ortec.info@ametek.com
801 South Illinois Ave., Oak Ridge, TN 37831-0895 U.S.A.
For International Office Locations, Visit Our Website

AMETEK[®]
ADVANCED MEASUREMENT TECHNOLOGY