

Photoconductive Cells and Analog Optoisolators (Vactrols®)

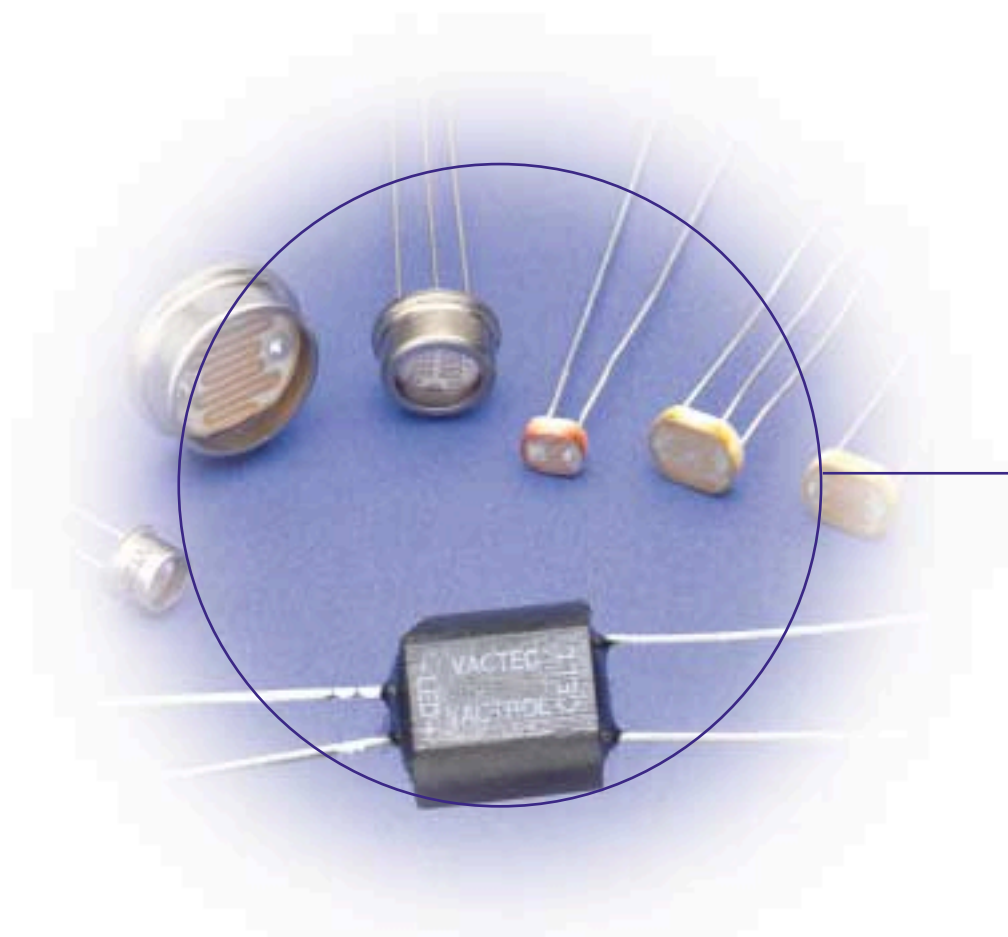

Specialty Lighting

Digital Imaging

Telecom

Sensors

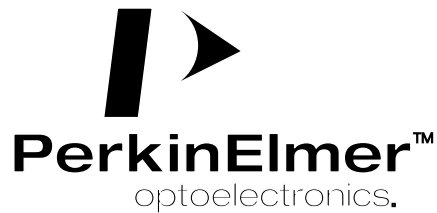

Optoswitches, optical hybrids, custom assemblies, photodiodes, phototransistors, IR emitters, and photoconductive cells for industrial, commercial, and consumer electronics applications.

PerkinElmer Optoelectronics has the distinction of being one of the foremost manufacturers in optoelectronics. Founded in 1947, PerkinElmer offers its customers over 35 years experience in the development and application of optoelectronic devices. The product line is one of the broadest in the industry, including a variety of standard catalog products as well as custom design and manufacturing capabilities. Approximately 75% of the products shipped are custom designed and tested to serve the needs of specific OEM applications.

Three basic objectives guide PerkinElmer's activities - **Service, Quality, and Technology.** Our outstanding engineering staff, coupled with the implementation of modern material control and manufacturing techniques, plus our commitment to quality, has gained PerkinElmer "certified" status with many major customers. Products are often shipped directly to manufacturing lines without need for incoming QC at the customer's facility. PerkinElmer's products are vertically integrated, from the growing of LED crystals, silicon die fabrication, package design, reliability qualification, to assembly. Vertical integration is your assurance of consistent quality.

Recognizing the need for low-cost manufacturing to serve world markets, PerkinElmer expanded its manufacturing/assembly operations into the Far East more than 20 years ago. The combination of strong technology in processing at the St. Louis headquarters and low-cost assembly operations in the Far East has allowed PerkinElmer to effectively serve all markets, worldwide. PerkinElmer provides optical sensors, IR emitters and subassemblies for such diverse applications as street light controls, cameras, smoke alarms, business machines, automotive sensors, and medical equipment.

For pricing, delivery, data sheets, samples, or technical support please contact your PerkinElmer Sales Office or direct your questions directly to the factory.

PerkinElmer Optoelectronics
10900 Page Avenue
St. Louis, Missouri 63132 USA
Tel: (314) 423-4900 Fax: (314) 423-3956

Copyright 2001 by
PerkinElmer Optoelectronics
All rights reserved
www.perkinelmer.com/opto

Table of Contents

Photoconductive Cells	1
What is a Photoconductive Cell?	2
Photoconductive Cell Typical Applications	3
Why Use Photocells?	3
Applications	3
Photoconductive Cell Typical Application Circuits	4
Selecting a Photocell	5
Photoconductive Cell Typical Characteristic Curves @ 25°C Type Ø Material	9
Type Ø Material	9
Photoconductive Cell Typical Characteristic Curves @ 25°C Type 3 Material	11
Type 3 Material	11
Photoconductive Cell Testing and General Notes	13
Production Testing of Photocells - PerkinElmer's New Approach	13
Device Specifications	14
Plastic Coated	
VT900 Series	14
VT800 Series	15
VT800CT Series	16
VT400 Series	17
Glass/Metal (Hermetic) Case	
VT200 Series	18
VT300 Series	19
VT300CT Series	20
VT500 Series	21
Application Notes—Photoconductive Cells	22
APPLICATION NOTE #1 Light - Some Physical Basics	22
APPLICATION NOTE #2 Light Resistance Measurement Techniques	23
APPLICATION NOTE #3 Spectral Output of Common Light Sources	23
APPLICATION NOTE #4 Spectral Matching of LEDs and Photoconductive Types	24
APPLICATION NOTE #5 Assembly Precautions	25
APPLICATION NOTE #6 A Low Cost Light Source for Measuring Photocells	25
APPLICATION NOTE #7 How to Specify a Low Cost Photocell	26

Table of Contents (Continued)

Analog Optical Isolators VACTROLS®	27
What Are Analog Optical Isolators?	28
Typical Applications of Analog Optical Isolators	32
Characteristics of Analog Optical Isolators	34
Transfer Characteristics	34
Response Time	34
Noise	34
Distortion	35
Voltage Rating	37
Power Rating	37
Life and Aging	37
Storage Characteristics	38
Temperature Range	38
Capacitance	39
Summary	39
Typical Transfer Characteristics (Resistance vs. Input Current) For Standard Vactrols	40
Analog Optoisolator Comparison Chart	41
Device Specifications	
VTL5C1, 5C2	43
VTL5C3, 5C4	45
VTL5C2/2, 5C3/2	47
VTL5C4/2	49
VTL5C6, 5C7	50
VTL5C8	51
VTL5C9, 5C10	55
Application Notes—Analog Optical Isolators	57
APPLICATION NOTE #1 Audio Applications	57
APPLICATION NOTE #2 Handling and Soldering AOIs	67
APPLICATION NOTE #3 Recommended Cleaning Agents	68

Custom and Semi-Custom Devices

Upon request, and where sufficient quantities are involved, PerkinElmer Optoelectronics will test standard parts to your unique set of specifications. The advantage of testing parts under actual operating conditions is predictable performance in the application.

PerkinElmer offers a broad line of standard photodiodes in a wide variety of packages and sensitivities. Nevertheless, some applications demand a totally custom device. Recognizing this real need, PerkinElmer's engineering, research, and sales departments are geared for working with the customer from initial concept through design, prototype, and volume production.

A custom design usually required the commitment of valuable resources. PerkinElmer reviews requests for custom devices on a case by case basis and reserves the right to decide if the business potential warrants the undertaking of such a project. The customer may be asked to share in the expense of development.

PerkinElmer has designed and fabricated custom products for many companies. PerkinElmer's staff can work closely with the customer and protect proprietary information. A custom design usually required the commitment of valuable resources. PerkinElmer reviews requests for custom devices on a case by case basis and reserves the right to decide if the business potential warrants the undertaking of such a project. The customer may be asked to share in the expense of development.

PerkinElmer has designed and fabricated custom products for many companies. PerkinElmer's staff can work closely with the customer and protect proprietary information.

Your inquiries to PerkinElmer should include electrical, environmental, and mechanical requirements. Also, information on anticipated volumes, price objectives, and lead times is helpful since these often determine the choices of design and tooling.

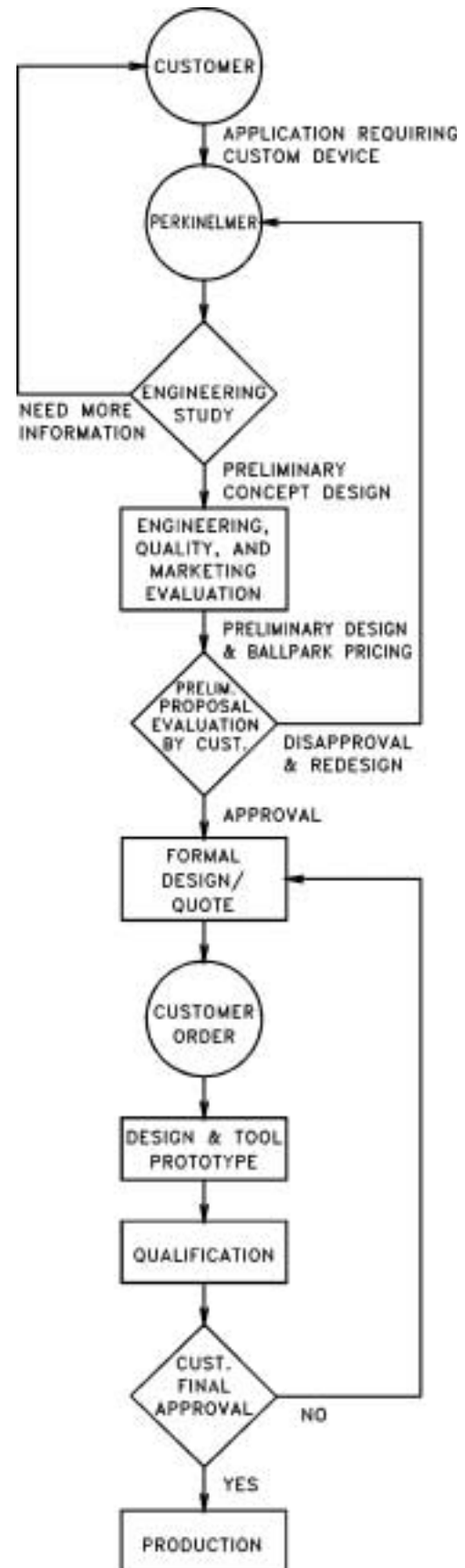

Photoconductive Cells

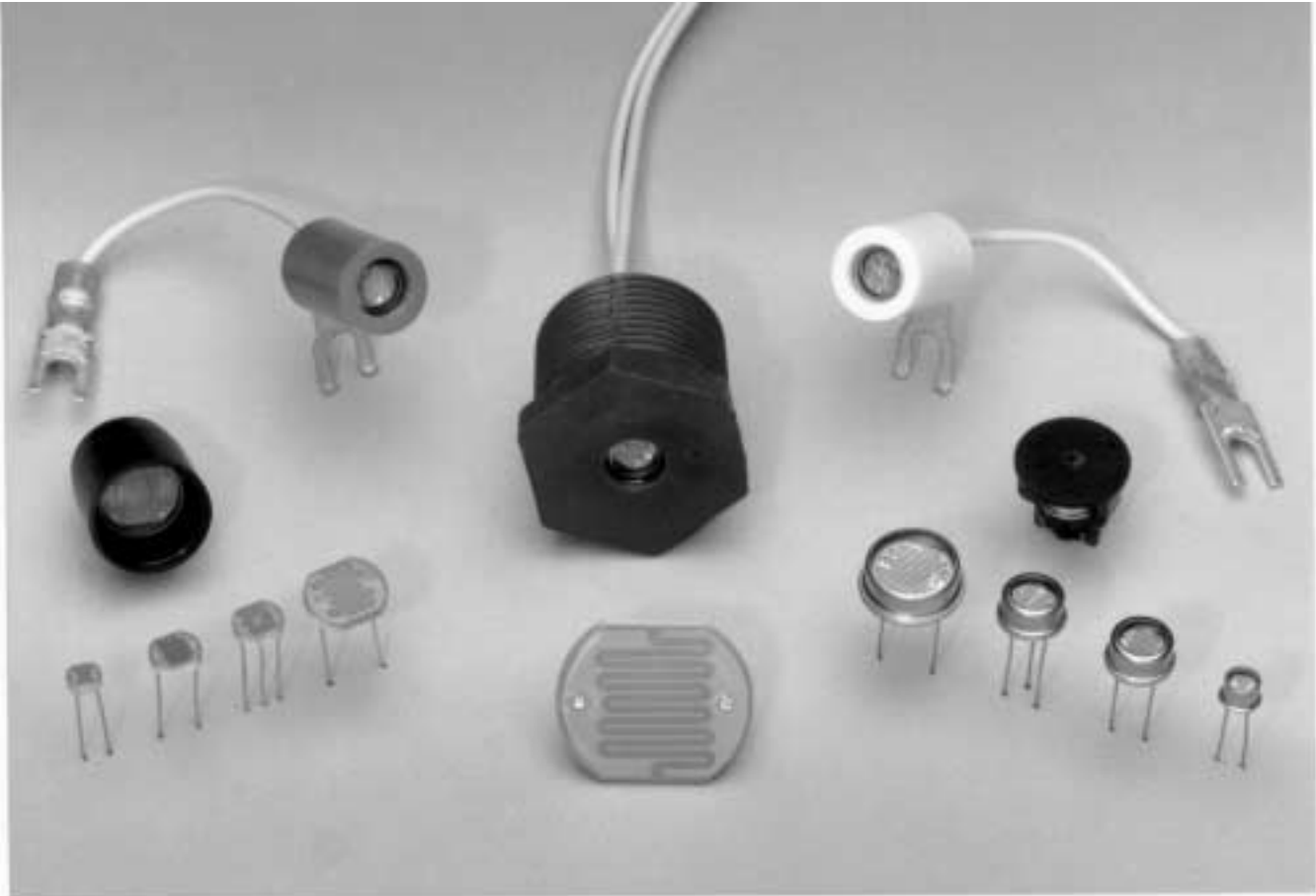

What is a Photoconductive Cell?

Semiconductor light detectors can be divided into two major categories: junction and bulk effect devices. Junction devices, when operated in the photoconductive mode, utilize the reverse characteristic of a PN junction. Under reverse bias, the PN junction acts as a light controlled current source. Output is proportional to incident illumination and is relatively independent of applied voltage as shown in Figure 1. Silicon photodiodes are examples of this type detector.

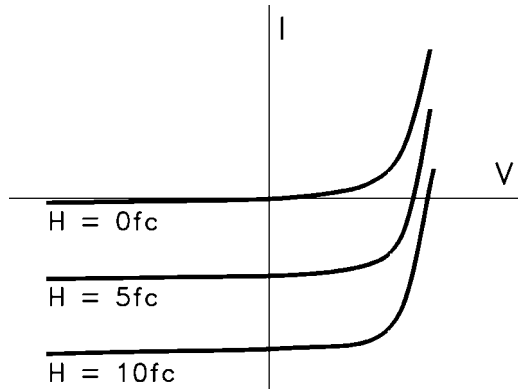

Figure 1
Junction Photoconductor (Photodiode)

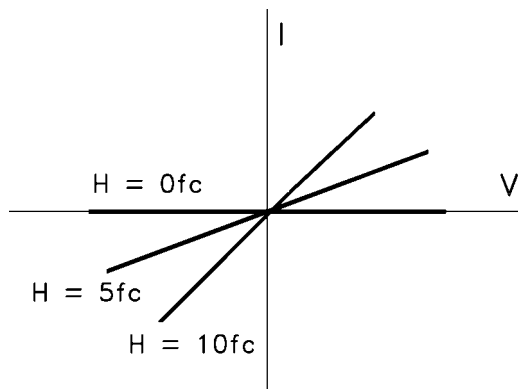

Figure 2
Bulk Effect Photoconductor (Photocell)

In contrast, bulk effect photoconductors have no junction. As shown in Figure 2, the bulk resistivity decreases with increasing illumination, allowing more photocurrent to flow. This resistive characteristic gives bulk effect photoconductors a unique quality: signal current from the detector can be varied over a wide range by adjusting the applied voltage. To clearly make this distinction, PerkinElmer Optoelectronics refers to its bulk effect photoconductors as photoconductive cells or simply photocells.

Photocells are thin film devices made by depositing a layer of a photoconductive material on a ceramic substrate. Metal contacts are evaporated over the surface of the photoconductor and external electrical connection is made to these contacts. These thin films of photoconductive material have a high sheet resistance. Therefore, the space between the two contacts is made narrow and interdigitated for low cell resistance at moderate light levels. This construction is shown in Figure 3.

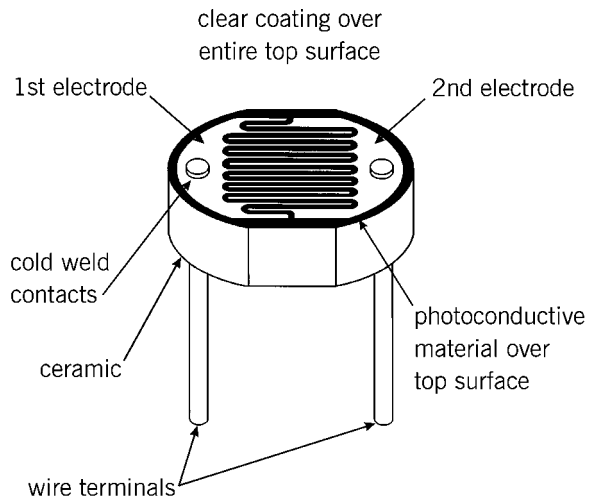

Figure 3
Typical Construction of a Plastic Coated Photocell

Photoconductive Cell Typical Applications

Why Use Photocells?

Photocells can provide a very economic and technically superior solution for many applications where the presence or absence of light is sensed (digital operation) or where the intensity of light needs to be measured (analog operation). Their general characteristics and features can be summarized as follows:

- *Lowest cost available and near-IR photo detector*
- *Available in low cost plastic encapsulated packages as well as hermetic packages (TO-46, TO-5, TO-8)*
- *Responsive to both very low light levels (moonlight) and to very high light levels (direct sunlight)*
- *Wide dynamic range: resistance changes of several orders of magnitude between "light" and "no light"*
- *Low noise distortion*
- *Maximum operating voltages of 50 to 400 volts are suitable for operation on 120/240 VAC*
- *Available in center tap dual cell configurations as well as specially selected resistance ranges for special applications*
- *Easy to use in DC or AC circuits - they are a light variable resistor and hence symmetrical with respect to AC waveforms*
- *Usable with almost any visible or near infrared light source such as LEDS; neon; fluorescent, incandescent bulbs, lasers; flame sources; sunlight; etc*
- *Available in a wide range of resistance values*

Applications

Photoconductive cells are used in many different types of circuits and applications.

Analog Applications

- *Camera Exposure Control*
- *Auto Slide Focus - dual cell*
- *Photocopy Machines - density of toner*
- *Colorimetric Test Equipment*
- *Densitometer*
- *Electronic Scales - dual cell*
- *Automatic Gain Control - modulated light source*
- *Automated Rear View Mirror*

Digital Applications

- *Automatic Headlight Dimmer*
- *Night Light Control*
- *Oil Burner Flame Out*
- *Street Light Control*
- *Absence / Presence (beam breaker)*
- *Position Sensor*

Photoconductive Cell Typical Application Circuits

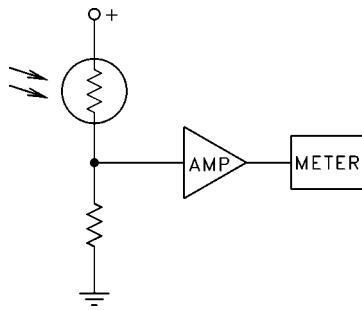

Ambient Light Measurement

Camera Exposure Meter (VT900)

Brightness Control (VT900)

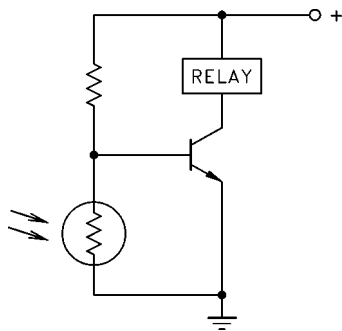

DC Relay

Rear View Mirror Control (VT200)

Head Light Dimmer (VT300 or VT800)

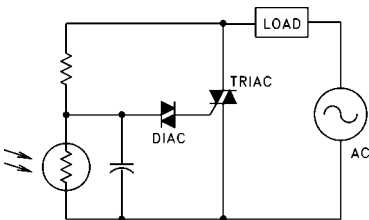

AC Relay

Night Light Control (VT800 or VT900)

Street Light Control (VT400)

Flame Detector (VT400 or 500)

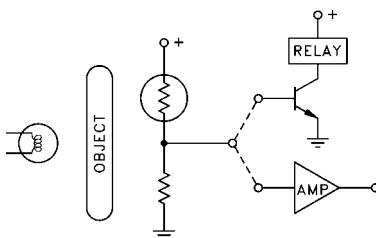

Object Sensing / Measurement

Beam Breaking Applications (VT800)

Security Systems (VT800 or VT900)

Colorimetric Test Equipment (VT200 or VT300)

Densitometer (VT200 or VT300)

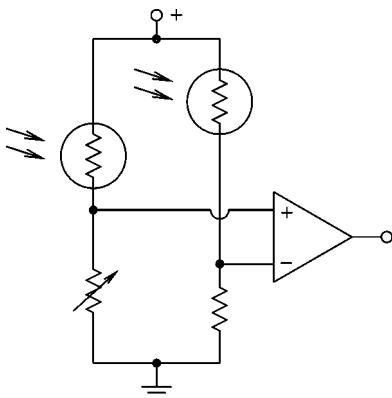

Bridge Circuits

Auto Focus (VT300CT or VT800CT)

Electronic Scales (VT300CT or VT800CT)

Photoelectric Servo (VT300CT or VT800CT)

Selecting a Photocell

Specifying the best photoconductive cell for your application requires an understanding of its principles of operation. This section reviews some fundamentals of photocell technology to help you get the best blend of parameters for your application.

When selecting a photocell the design engineer must ask two basic questions:

1. What kind of performance is required from the cell?
2. What kind of environment must the cell work in?

Performance Criteria

Sensitivity

The sensitivity of a photodetector is the relationship between the light falling on the device and the resulting output signal. In the case of a photocell, one is dealing with the relationship between the incident light and the corresponding resistance of the cell.

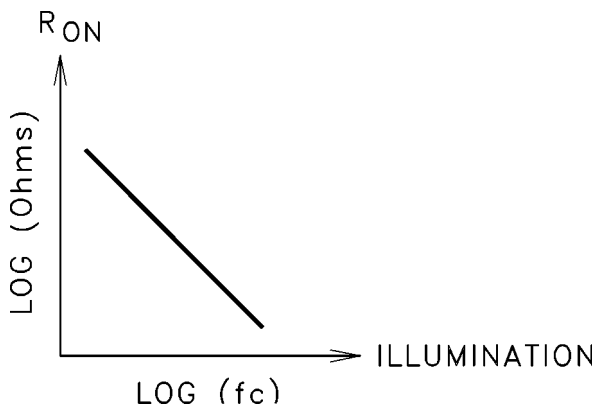

Defining the sensitivity required for a specific application can prove to be one of the more difficult aspects in specifying a photoconductor. In order to specify the sensitivity one must, to some degree, characterize the light source in terms of its intensity and its spectral content.

Within this handbook you will find curves of resistance versus light intensity or illumination for many of PerkinElmer's stock photocells. The illumination is expressed in units of fc (foot candles) and lux. The light source is an incandescent lamp. This lamp is special only in that the spectral composition of the light it generates matches that of a black body at a color temperature of 2850 K. This type of light source is an industry agreed to standard.

Over the years PerkinElmer has developed different "types" of photoconductive materials through modifications made to the chemical

composition of the detector. For a given type of photoconductor material, at a given level of illumination, the photoconductive film will have a certain sheet resistivity. The resistance of the photocell at this light level is determined by the electrode geometry.

$$R_H = \rho_H (w/l)$$

where:

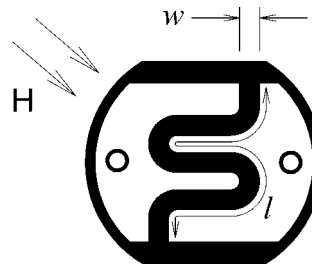

R_H = resistance of cell at light level H

ρ_H = sheet resistivity of photoconductive film at light level H

w = width of electrode gap

l = length of electrode gap

Sheet sensitivity (ρ_H) for photoconductive films at 2 fc are in the range of 20 M Ω per square.

The ratio w/l can be varied over a wide range in order to achieve design goals. Typical values for w/l run from 0.002 to 0.5, providing flexibility for terminal resistance and maximum cell voltage.

Spectral Response

Like the human eye, the relative sensitivity of a photoconductive cell is dependent on the wavelength (color) of the incident light. Each photoconductor material type has its own unique spectral response curve or plot of the relative response of the photocell versus wavelength of light.

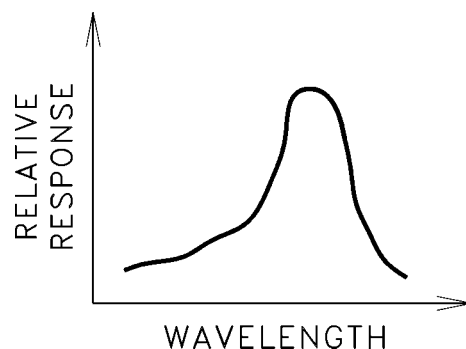

The spectral response curves for PerkinElmer's material types are given in the handbook and should be considered in selecting a photocell for a particular application.

Selecting a Photocell

Slope Characteristics

Plots of the resistance for the photocells listed in this catalog versus light intensity result in a series of curves with characteristically different slopes. This is an important characteristic of photocells because in many applications not only is the absolute value of resistance at a given light level of concern but also the value of the resistance as the light source is varied. One way to specify this relationship is by the use of parameter (gamma) which is defined as a straight line passing through two specific points on the resistance curve. The two points used by PerkinElmer to define γ are 10 lux (0.93 fc) and 100 lux (9.3 fc).

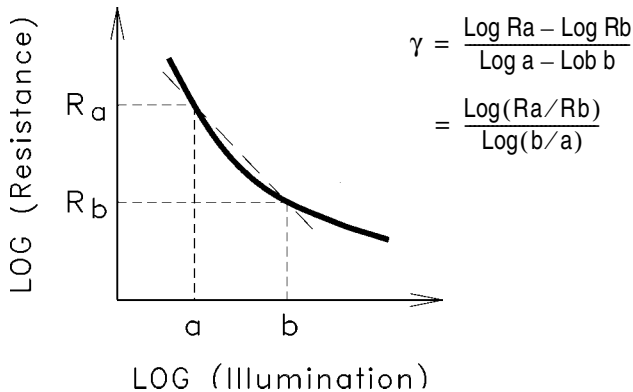

Applications for photocells are of one of two categories: digital or analog. For the digital or ON-OFF types of applications such as flame detectors, cells with steep slopes to their resistance versus light intensity curves are appropriate. For analog or measurement types of applications such as exposure controls for cameras, cells with shallow slopes might be better suited.

Resistance Tolerance

The sensitivity of a photocell is defined as its resistance at a specific level of illumination. Since no two photocells are exactly alike, sensitivity is stated as a typical resistance value plus an allowable tolerance. Both the value of resistance and its tolerance are specified for only one light level. For moderate excursions from this specified light level the tolerance level remain more or less constant. However, when the light level the tolerance level remain more or less constant. However, when the light level is decades larger or smaller than the reference level the tolerance can differ considerably.

As the light level decreases, the spread in the tolerance level increases. For increasing light levels the resistance tolerance will tighten.

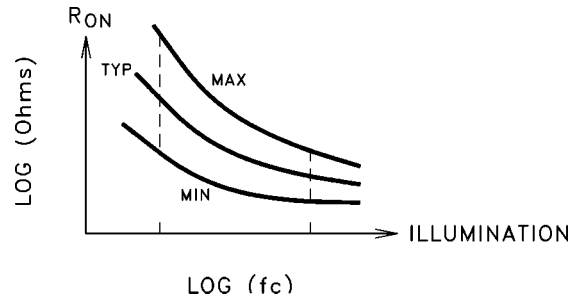

Likewise, for dual element photocells the matching factor, which is defined as the ratio of the resistance of between elements, will increase with decreasing light level.

Dual Element Photocell Typical Matching Ratios				
0.01 fc	0.1 fc	1.0 fc	10 fc	100 fc
0.63 - 1.39	0.74 - 1.27	0.75 - 1.25	0.76 - 1.20	0.77 - 1.23

Dark Resistance

As the name implies, the dark resistance is the resistance of the cell under zero illumination lighting conditions. In some applications this can be very important since the dark resistance defines what maximum "leakage current" can be expected when a given voltage is applied across the cell. Too high a leakage current could lead to false triggering in some applications.

The dark resistance is often defined as the minimum resistance that can be expected 5 seconds after the cell has been removed from a light intensity of 2 fc. Typical values for dark resistance tend to be in the 500k ohm to 20M ohm range.

Temperature Coefficient of Resistance.

Each type of photoconductive material has its own resistance versus temperature characteristic. Additionally, the temperature coefficients of photoconductors are also dependent on the light level the cells are operating at.

From the curves of the various types of materials it is apparent that the temperature coefficient is an inverse function of light level. Thus, in order to minimize temperature problems it is desirable to have the cell operating at the highest light level possible.

Speed of Response

Speed of response is a measure of the speed at which a photocell responds to a change from light-to-dark or from dark-to-light. The rise time is defined as the time necessary for the light conductance of the photocell to reach 1-1/e (or about 63%) of its final value.

Selecting a Photocell

The decay or fall time is defined as the time necessary for the light conductance of the photocell to decay to 1/e (or about 73%) of its illuminated state. At 1 fc of illumination the response times are typically in the range of 5 msec to 100 msec.

The speed of response depends on a number of factors including light level, light history, and ambient temperature. All material types show faster speed at higher light levels and slower speed at lower light levels. Storage in the dark will cause slower response than if the cells are kept in the light. The longer the photocells are kept in the dark the more pronounced this effect will be. In addition, photocells tend to respond slower in colder temperatures.

Light History

All photoconductive cells exhibit a phenomenon known as hysteresis, light memory, or light history effect. Simply stated, a photocell tends to remember its most recent storage condition (light or dark) and its instantaneous conductance is a function of its previous condition. The magnitude of the light history effect depends upon the new light level, and upon the time spent at each of these light levels. This effect is reversible.

To understand the light history effect, it is often convenient to make an analogy between the response of a photocell and that of a human eye. Like the cell, the human eye's sensitivity to light depends on what level of light it was recently exposed to. Most people have had the experience of coming in from the outdoors on a bright summer's day and being temporarily unable to see under normal room levels of illumination. Your eyes will adjust but a certain amount of time must elapse first. How quickly one's eyes adjust depends on how bright it was outside and how long you remained outdoors.

The following guide shows the general relationship between light history and light resistance at various light levels. The values shown were determined by dividing the resistance of a given cell, following infinite light history (R_{LH}), by the resistance of the same cell following "infinite" dark history (R_{DH}). For practical purposes, 24 hours in the dark will achieve R_{DH} or 24 hours at approximately 30 fc will achieve R_{LH} .

Typical Variation of Resistance with Light History Expressed as a Ratio R_{LH} / R_{DH} at Various Test Illumination Levels.

	Illumination				
R_{LH} / R_{DH} Ratio	0.01 fc	0.1 fc	1.0 fc	10 fc	100 fc
	1.55	1.35	1.20	1.10	1.10

This guide illustrates the fact that a photocell which has been stored for a long time in the light will have a considerably higher light resistance than if it was stored for a long time in the dark. Also, if a cell is stored for a long period of time at a light level higher than the test level, it will have a higher light resistance than if it was stored at a light level closer to the test light level.

This effect can be minimized significantly by keeping the photocell exposed to some constant low level of illumination (as opposed to having it sit in the dark). This is the reason resistance specifications are characterized after 16 hours light adept.

Environmental/Circuitry Considerations

Packaging

In order to be protected from potentially hostile environments photocells are encapsulated in either glass/metal (hermetic) package or are covered with a clear plastic coating. While the hermetic packages provide the greatest degree of protection, a plastic coating represents a lower cost approach.

The disadvantage of plastic coatings is that they are not an absolute barrier to eventual penetration by moisture. This can have an adverse effect on cell life. However, plastic coated photocells have been used successfully for many years in such hostile environments as street light controls.

Temperature Range

The chemistry of the photoconductive materials dictates an operating and storage temperature range of -40°C to 75°C . It should be noted that operation of the cell above 75°C does not usually lead to catastrophic failure but the photoconductive surface may be damaged leading to irreversible changes in sensitivity.

The amount of resistance change is a function of time as well as temperature. While changes of several hundred percent will occur in a matter of a few minutes at 150°C , it will take years at 50°C to produce that much change.

Power Dissipation

During operation, a cell must remain within its maximum internal temperature rating of 75°C . Any applied power will raise the cell's temperature above ambient and must be considered.

Selecting a Photocell

Many low voltage situations involve very little power, so that the photocell can be small in size, where voltages and/or currents are higher, the photocell must be physically larger so that the semiconductor film can dissipate the heat.

The following curve of power dissipation versus ambient temperature describes the entire series of cells for operation in free air at room ambient (25°C). Note that regardless the size, all photocells derate linearly to zero at an ambient temperature of 75°C. The adequate heat sinks can increase the dissipation by as much as four times the levels shown in this graph.

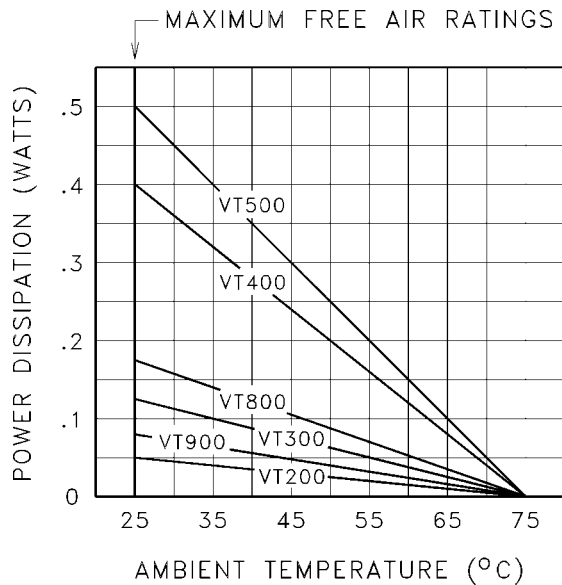

Maximum Cell Voltage

At no time should the peak voltage of the cell exceed its maximum voltage. The designer should determine the maximum operating or peak voltage that the cell will experience in the circuit and choose an appropriately rated cell. Typical voltage rates range from 100V to 300V.

What Type of Material is Best?

Each specific material type represents a trade off between several characteristics. Selecting the best material is a process of determining which characteristics are most important in the application.

PerkinElmer's standard photocells in this catalog are manufactured using one of two different material types offered: type "Ø" or type "3".

In general, material type "Ø" is used for applications such as nightlights, automotive sensors. Material type "3" is primarily used in camera, streetlight control, and flame detector applications.

Photoconductive Cell Typical Characteristic Curves

@ 25°C Type Ø Material

Type Ø Material

This is a general purpose material. Its characteristics include a good temperature coefficient and fast response time, especially at very low light levels. Cells of this type have relatively low dark history. Type Ø material is often used in lighting controls such as nightlights, and security lighting.

The resistance for any standard catalog cell is controlled at only one light level. If the resistance at other light levels is a concern, please contact the factory.

To obtain the typical resistance versus illumination characteristic for a specific part number:

1. Look up 2 footcandle resistance in table.
2. Insert resistance given and draw a curve through that point and parallel to the closest member of the family of curves shown for the appropriate type of photo-sensitive material.

Resistance vs. Illumination

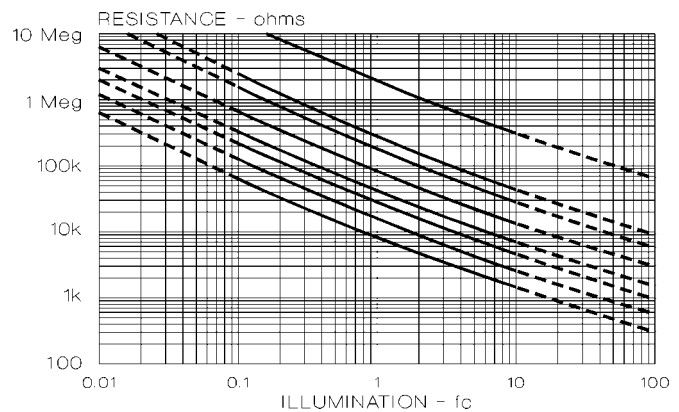

Response Time vs. Illumination (Rise Time)

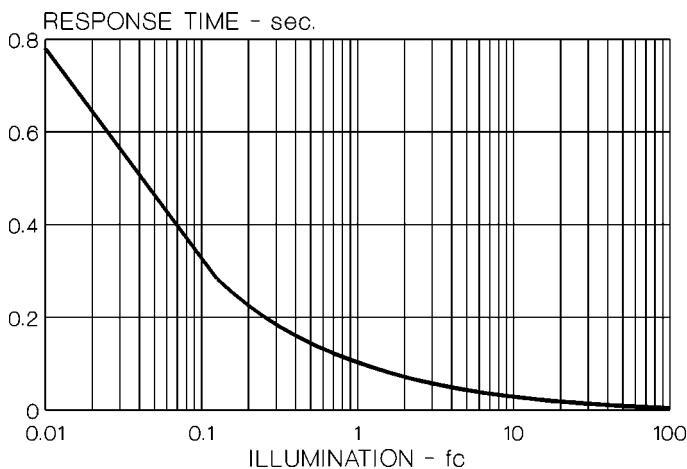

Response Time vs. Illumination (Decay Time)

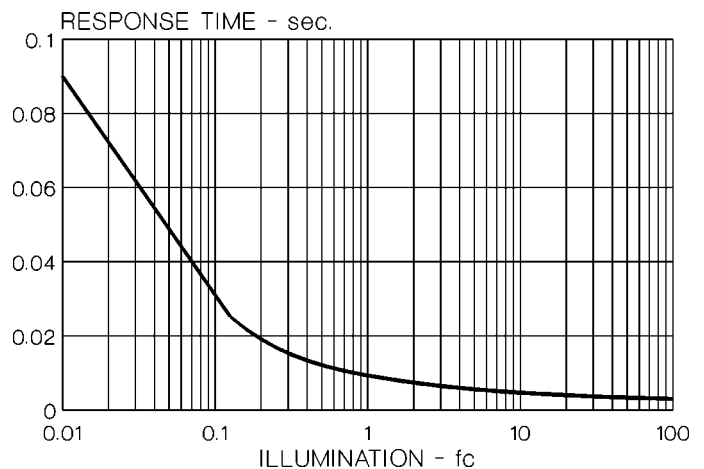

Photoconductive Cell Typical Characteristic Curves

@ 25°C Type Ø Material

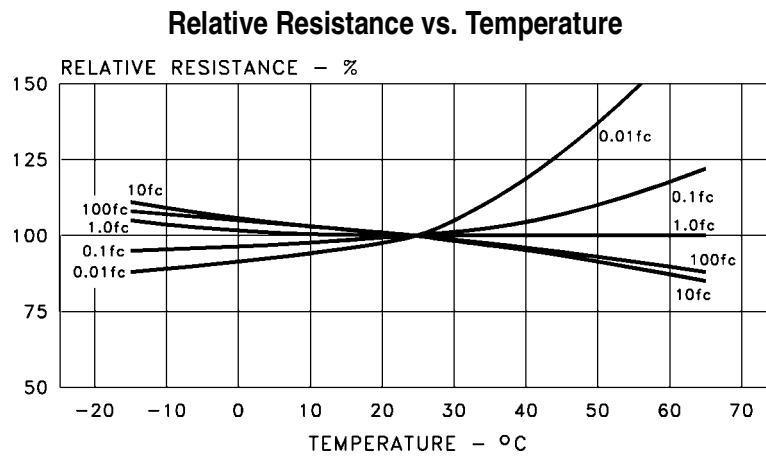
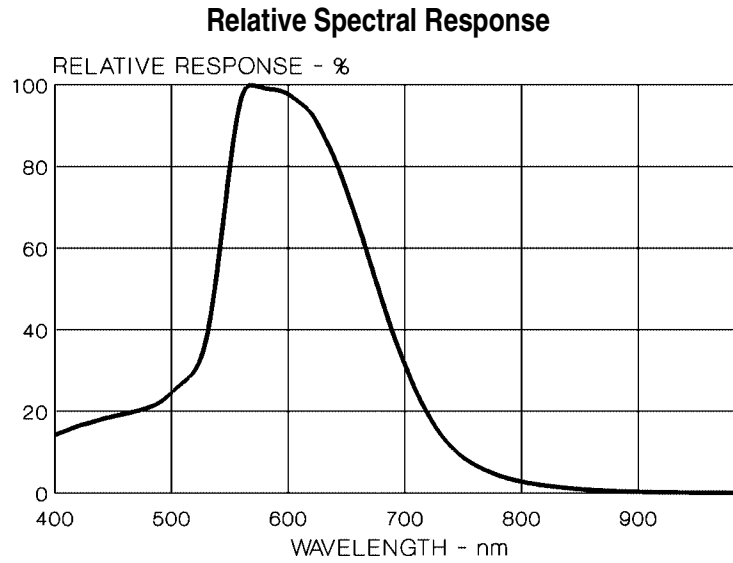

Photoconductive Cell Typical Characteristic Curves

@ 25°C Type 3 Material

Type 3 Material

This is a high speed material with a spectral response closely approximating the human eye. This material is well suited for switching from one light level to another and offers our best temperature stability and response time. This material is often used in cameras and industrial controls.

The resistance for any standard catalog cell is controlled at only one light level. If the resistance at other light levels is a concern, please contact the factory.

To obtain the typical resistance versus illumination characteristic for a specific part number:

1. Look up 2 footcandle resistance in table.
2. Insert resistance given and draw a curve through that point and parallel to the closest member of the family of curves shown for the appropriate type of photo-sensitive material.

Resistance vs. Illumination

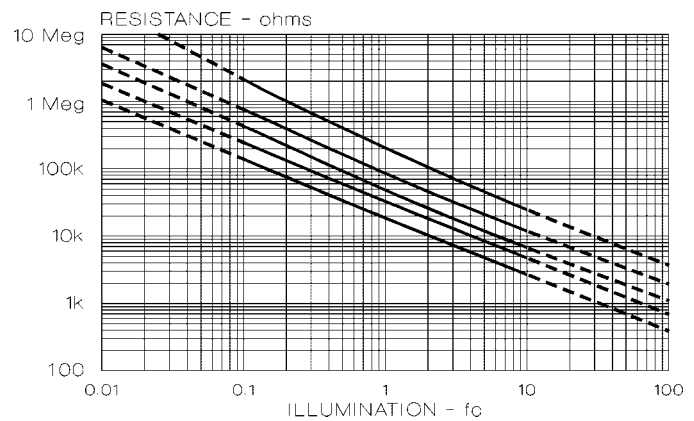

**Response Time vs. Illumination
(Rise Time)**

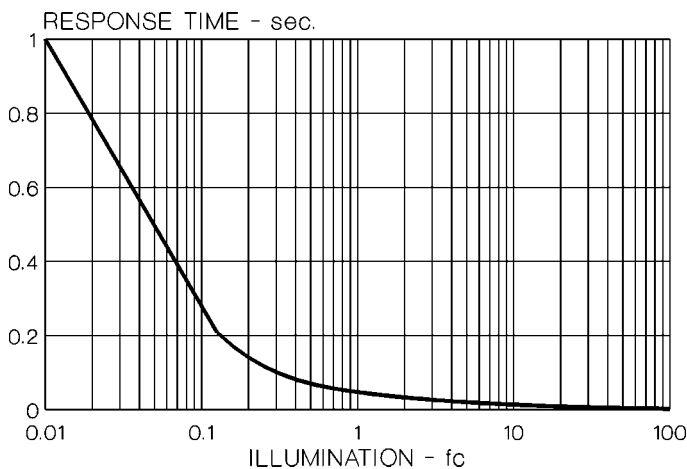

**Response Time vs. Illumination
(Decay Time)**

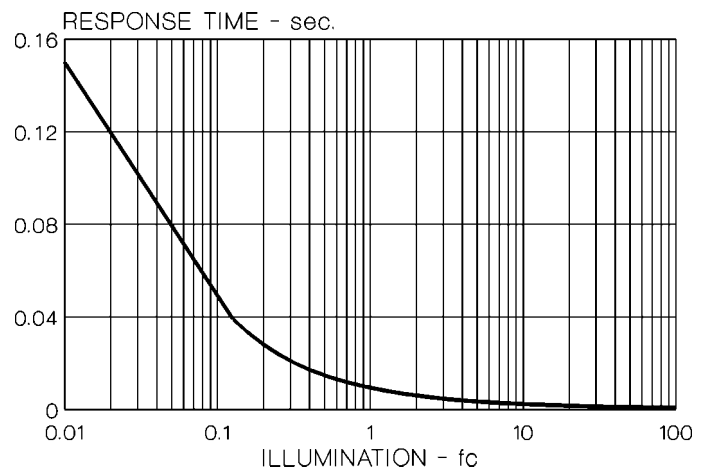

Photoconductive Cell Typical Characteristic Curves

@ 25°C Type 3 Material

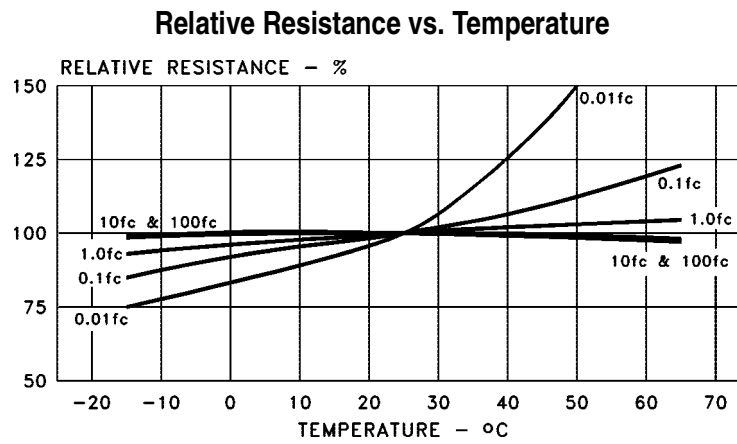
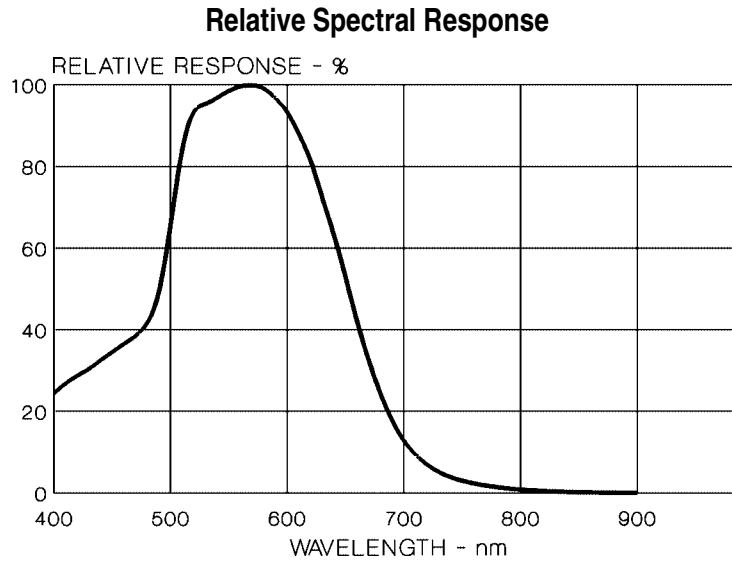

Photoconductive Cell Testing and General Notes

Production Testing of Photocells - PerkinElmer's New Approach

Historically within this industry, vendors have set their production testers to the limits specified on the customer's print. Measurement errors due to ambient temperature, calibration of light source, light history effect, plus any tester errors have always guaranteed that a certain percentage of the cells shipped are out of specification.

This practice is incompatible with the realities of today's marketplace, where quality levels are being measured in parts per million.

With this new catalog, PerkinElmer is taking the opportunity to correct this situation. For parts in this catalog, PerkinElmer has pulled in the test limits on our production testers to compensate for measurement errors.

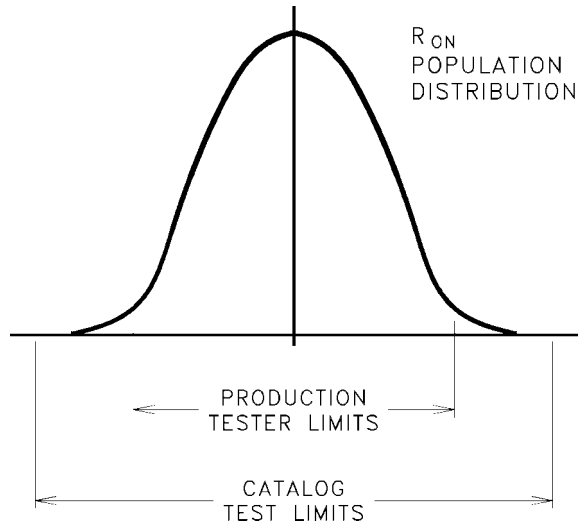

General Notes

(Refer to the following data specification pages.)

- 1** Photocells are supplied categorized into groups by resistance. All groups must be purchased together and PerkinElmer maintains the right to determine the product mix among these groups.
- 2** Dimension controlled at base of package.
- 3** Photocells are tested at either 1 fc or 10 lux. 2 fc typical values shown in the tables are for reference only.
- 4** Cells are light adapted at 30 - 50 fc.
- 5** The photocell "grid" pattern can vary from that shown. PerkinElmer reserves the right to change mix grid patterns on any standard product.
- 6** The resistance for any standard cell is controlled at only one light level. If the resistance at other light levels is a concern, please contact the factory.

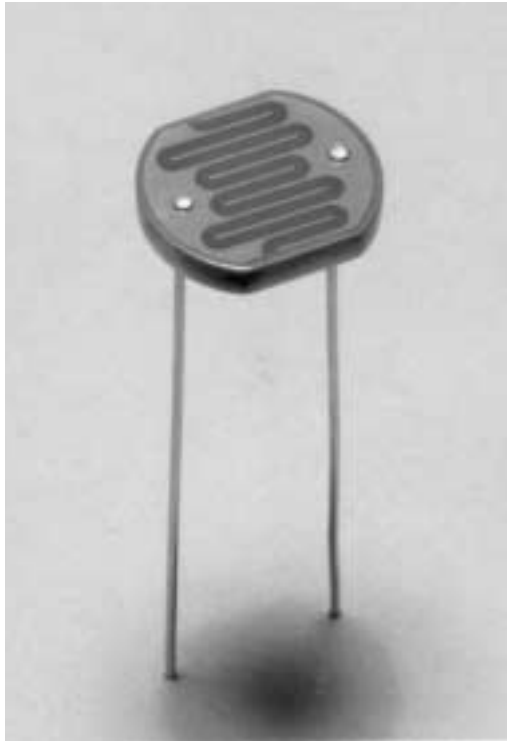

PACKAGE DIMENSIONS inch (mm)

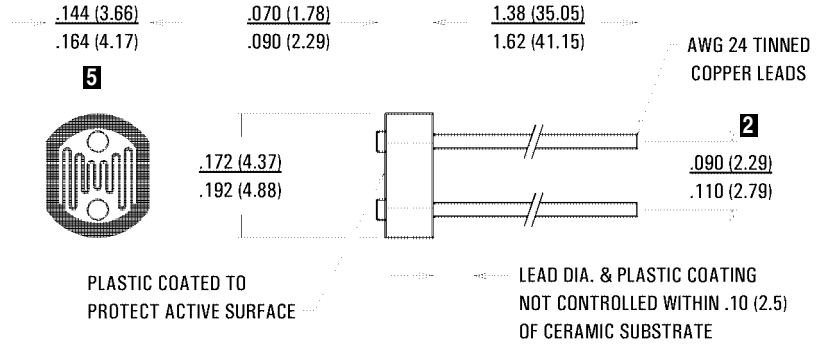

ABSOLUTE MAXIMUM RATINGS

Parameter	Symbol	Rating	Units
Continuous Power Dissipation Derate Above 25°C	P_D $\Delta P_D / \Delta T$	80 1.6	mW mW/°C
Temperature Range Operating and Storage	T_A	-40 to +75	°C

ELECTRO-OPTICAL CHARACTERISTICS @ 25°C (16 hrs. light adapt, min.) 4

Part Number	Resistance (Ohms) 3 6						Material Type	Sensitivity (γ , typ.) $\frac{\text{LOG}(R_{10}/R_{100})}{\text{LOG}(100/10)}$	Maximum Voltage (V, pk)	Response Time @ 1 fc (ms, typ.)		
	10 lux 2850 K			2 fc 2850 K	Dark					Rise (1-1/e)	Fall (1/e)	
	Min.	Typ.	Max.	Typ.	Min.	sec.						
VT9ØN1	6 k	12 k	18 k	6 k	200 k	5	Ø	0.80	100	78	8	
VT9ØN2	12 k	24 k	36 k	12 k	500 k	5	Ø	0.80	100	78	8	
VT9ØN3	25 k	50 k	75 k	25 k	1 M	5	Ø	0.85	100	78	8	
VT9ØN4	50 k	100 k	150 k	50 k	2 M	5	Ø	0.90	100	78	8	
VT93N1	12 k	24 k	36 k	12 k	300 k	5	3	0.90	100	35	5	
VT93N2	24 k	48 k	72 k	24 k	500 k	5	3	0.90	100	35	5	
VT93N3	50 k	100 k	150 k	50 k	500 k	5	3	0.90	100	35	5	
VT93N4	100 k	200 k	300 k	100 k	500 k	5	3	0.90	100	35	5	
VT935G												
1	Group A	10 k	18.5 k	27 k	9.3 k	1 M	5	3	0.90	100	35	5
	Group B	20 k	29 k	38 k	15 k	1 M	5	3	0.90	100	35	5
	Group C	31 k	40.5 k	50 k	20 k	1 M	5	3	0.90	100	35	5

See page 13 for notes.

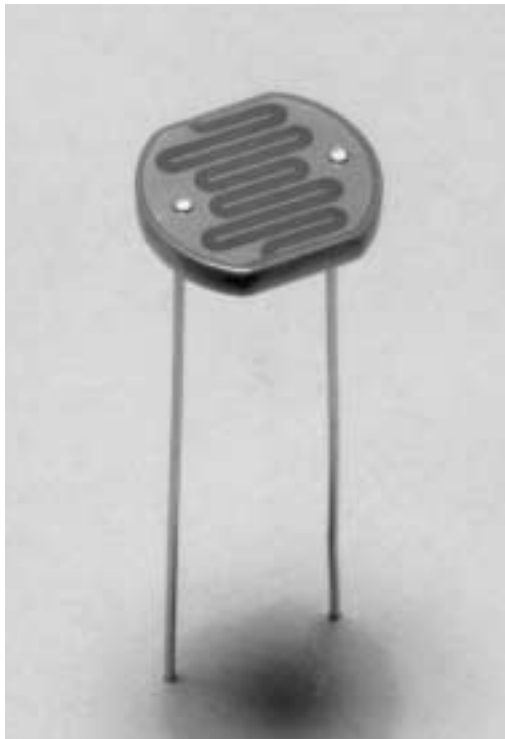

PACKAGE DIMENSIONS inch (mm)

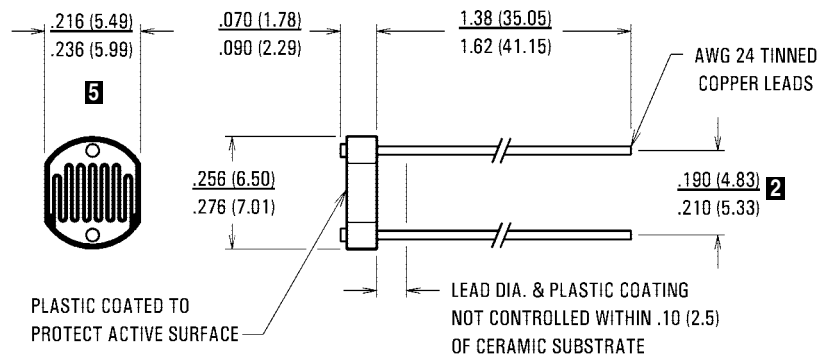

ABSOLUTE MAXIMUM RATINGS

Parameter	Symbol	Rating	Units
Continuous Power Dissipation Derate Above 25°C	P_D $\Delta P_D / \Delta T$	175 3.5	mW mW/°C
Temperature Range Operating and Storage	T_A	-40 to +75	°C

ELECTRO-OPTICAL CHARACTERISTICS @ 25°C (16 hrs. light adapt, min.) 4

Part Number	Resistance (Ohms) 3 6						Material Type	Sensitivity (γ , typ.) $\frac{OG(R_{10}/R_{100})}{LOG(100/10)}$	Maximum Voltage (V, pk)	Response Time @ 1 fc (ms, typ.)	
	10 lux 2850 K			2 fc 2850 K	Dark					Rise (1-1/e)	Fall (1/e)
	Min.	Typ.	Max.	Typ.	Min.	sec.					
VT80N1	4 k	8 k	12 k	4 k	100 k	5	Ø	0.80	100	78	8
VT80N2	8 k	16 k	24 k	8 k	500 k	5	Ø	0.80	200	78	8
VT83N1	6 k	12 k	18 k	6 k	100 k	5	3	0.95	100	35	5
VT83N2	12 k	28 k	36 k	14 k	500 k	5	3	0.95	200	35	5
VT83N3	24 k	48 k	72 k	24 k	1 M	5	3	0.95	200	35	5
VT83N4	50 k	100 k	150 k	50 k	2 M	5	3	0.95	200	35	5

See page 13 for notes.

PACKAGE DIMENSIONS inch (mm)

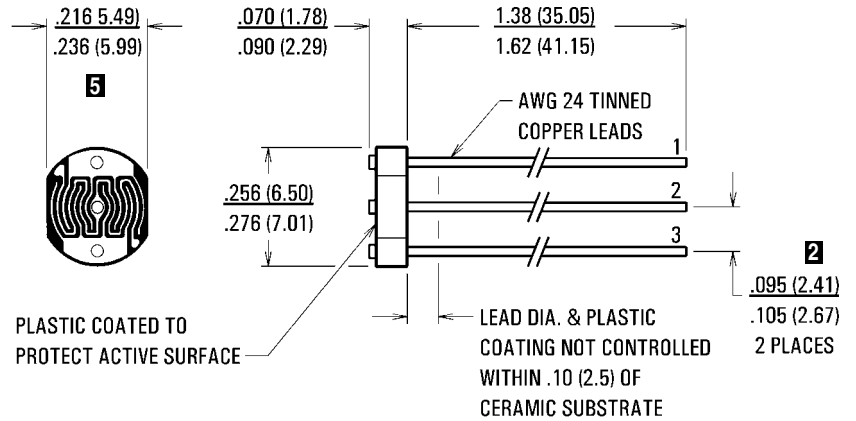
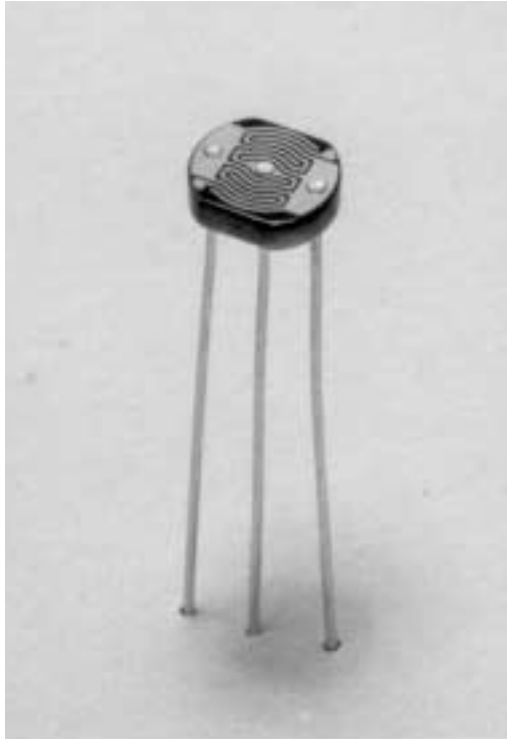

ABSOLUTE MAXIMUM RATINGS

Parameter	Symbol	Rating	Units
Continuous Power Dissipation (Per Element) Derate Above 25°C	P_D $\Delta P_D / \Delta T$	80 1.6	mW mW/°C
Temperature Range Operating and Storage	T_A	-40 to +75	°C

ELECTRO-OPTICAL CHARACTERISTICS @ 25°C (16 hrs. light adapt, min.)

Part Number	Resistance Per Element (Ohms)						Matching @ 10 Lux R_{1-2} / R_{2-3}	Material Type	Sensitivity (γ , typ.) $\frac{OG (R_{10}/R_{100})}{LOG (100/10)}$	Maximum Voltage (V, pk)	Response Time @ 1 fc (ms, typ.)	
	10 lux 2850 K			2 fc 2850 K	Dark						Rise (1-1/e)	Fall (1/e)
	Min.	Typ.	Max.	Typ.	Min.	sec.						
VT83CT	30 k	60 k	90 k	30 k	1 M	5	0.70 - 1.30	3	0.90	100	35	5

See page 13 for notes.

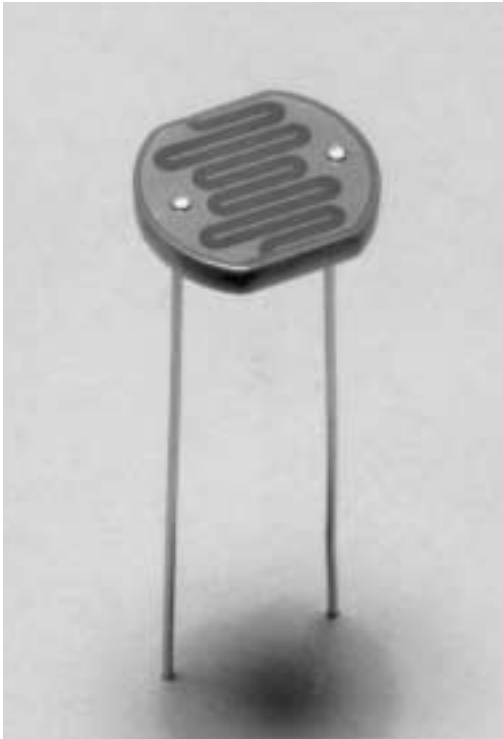

PACKAGE DIMENSIONS inch (mm)

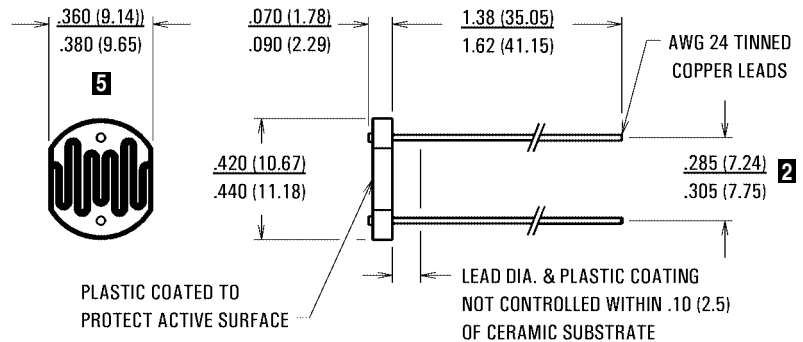

ABSOLUTE MAXIMUM RATINGS

Parameter	Symbol	Rating	Units
Continuous Power Dissipation	P_D	400	mW
Demand (20 minutes)		600	mW
Derate Above 25°C	$\Delta P_D / \Delta T$	8.0	mW/°C
Temperature Range Operating and Storage	T_A	-40 to +75	°C

ELECTRO-OPTICAL CHARACTERISTICS @ 25°C (16 hrs. light adapt, min.)

Part Number	Resistance (Ohms) 3 6						Material Type	Sensitivity (γ , typ.) <small>$\frac{OG(R_{10}/R_{100})}{LOG(100/10)}$</small>	Maximum Voltage (V, pk)	Response Time @ 1 fc (ms, typ.)	
	1 fc 6500 K			2 fc 2850 K	Dark					Rise (1-1/e)	Fall (1/e)
	Min.	Typ.	Max.	Typ.	Min.	sec.					
VT43N1	4 k	8 k	12 k	—	300 k	30	3	0.90	250	90	18
VT43N2	8 k	16 k	24 k	—	300 k	30	3	0.90	250	90	18
VT43N3	16 k	32 k	48 k	—	500 k	30	3	0.90	400	90	18
VT43N4	33 k	66 k	100 k	—	500 k	30	3	0.90	400	90	18

See page 13 for notes.

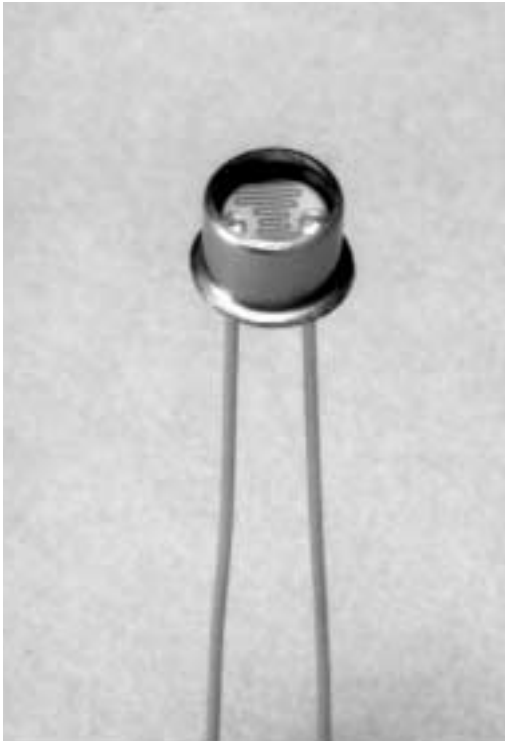

PACKAGE DIMENSIONS inch (mm)

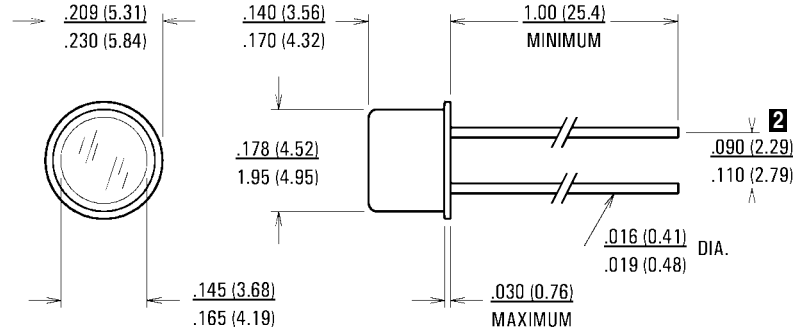

ABSOLUTE MAXIMUM RATINGS

Parameter	Symbol	Rating	Units
Continuous Power Dissipation Derate Above 25°C	P_D $\Delta P_D / \Delta T$	50 1.0	mW mW/°C
Temperature Range Operating and Storage	T_A	-40 to +75	°C

ELECTRO-OPTICAL CHARACTERISTICS @ 25°C (16 hrs. light adapt, min.) 4

Part Number	Resistance (Ohms) 3 6						Material Type	Sensitivity (γ , typ.) $\frac{\text{LOG}(R_{10}/R_{100})}{\text{LOG}(100/10)}$	Maximum Voltage (V, pk)	Response Time @ 1 fc (ms, typ.)	
	10 lux 2850 K			2 fc 2850 K	Dark					Rise (1-1/e)	Fall (1/e)
	Min.	Typ.	Max.	Typ.	Min.	sec.					
VT2ØN1	8 k	16 k	24 k	8 k	200 k	5	Ø	0.80	100	78	8
VT2ØN2	16 k	34 k	52 k	17 k	500 k	5	Ø	0.80	100	78	8
VT2ØN3	36 k	72 k	108 k	36 k	1 M	5	Ø	0.80	100	78	8
VT2ØN4	76 k	152 k	230 k	76 k	2 M	5	Ø	0.80	200	78	8
VT23N1	20 k	40 k	60 k	20 k	500 k	5	3	0.85	100	35	5
VT23N2	42 k	86 k	130 k	43 k	1 M	5	3	0.85	100	35	5
VT23N3	90 k	180 k	270 k	90 k	2 M	5	3	0.85	100	35	5

See page 13 for notes.



PACKAGE DIMENSIONS inch (mm)

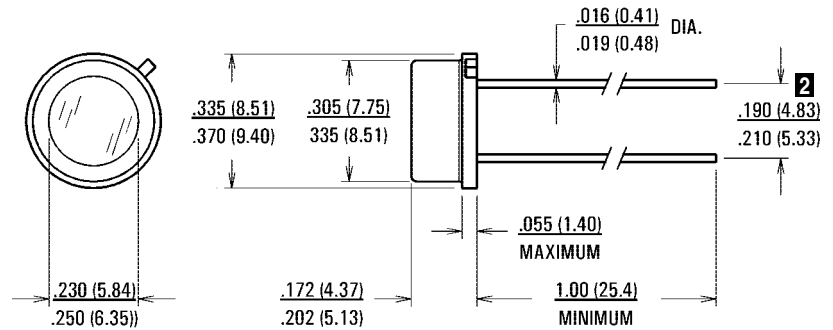

ABSOLUTE MAXIMUM RATINGS

Parameter	Symbol	Rating	Units
Continuous Power Dissipation Derate Above 25°C	P_D $\Delta P_D / \Delta T$	125 2.5	mW mW/°C
Temperature Range Operating and Storage	T_A	-40 to +75	°C

ELECTRO-OPTICAL CHARACTERISTICS @ 25°C (16 hrs. light adapt, min.) 4

Part Number	Resistance (Ohms) 3 6						Material Type	Sensitivity (γ , typ.) $\frac{OG(R_{10}/R_{100})}{LOG(100/10)}$	Maximum Voltage (V, pk)	Response Time @ 1 fc (ms, typ.)	
	10 lux 2850 K			2 fc 2850 K	Dark					Rise (1-1/e)	Fall (1/e)
	Min.	Typ.	Max.	Typ.	Min.	sec.					
VT30N1	6 k	12 k	18 k	6 k	200 k	5	Ø	0.75	100	78	8
VT30N2	12 k	24 k	36 k	12 k	500 k	5	Ø	0.80	200	78	8
VT30N3	24 k	48 k	72 k	24 k	1 M	5	Ø	0.80	200	78	8
VT30N4	50 k	100 k	150 k	50 k	2 M	5	Ø	0.80	300	78	8
VT33N1	20 k	40 k	60 k	20 k	500 k	5	3	0.90	100	35	5
VT33N2	40 k	80 k	120 k	40 k	1 M	5	3	0.90	200	35	5
VT33N3	80 k	160 k	240 k	80 k	2 M	5	3	0.90	200	35	5

See page 13 for notes.

PACKAGE DIMENSIONS inch (mm)

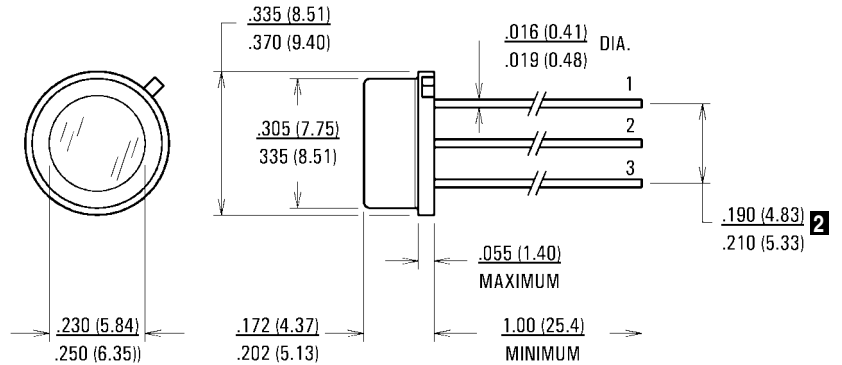

ABSOLUTE MAXIMUM RATINGS

Parameter	Symbol	Rating	Units
Continuous Power Dissipation (Per Element) Derate Above 25°C	P_D $\Delta P_D / \Delta T$	50 1.0	mW mW/°C
Temperature Range Operating and Storage	T_A	-40 to +75	°C

ELECTRO-OPTICAL CHARACTERISTICS @ 25°C (16 hrs. light adapt, min.) 4

Part Number	Resistance Per Element (Ohms) 3 6						Matching 10 Lux R_{1-2} / R_{2-3}	Material Type	Sensitivity (γ , typ.) $\frac{OG (R_{10}/R_{100})}{LOG (100/10)}$	Maximum Voltage (V, pk)	Response Time @ 1 fc (ms, typ.)	
	10 lux 2850 K			2 fc 2850 K	Dark						Rise (1-1/e)	Fall (1/e)
	Min.	Typ.	Max.	Typ.	Min.	sec.						
VT30CT	10 k	20 k	30 k	10 k	500 k	5	0.70 – 1.30	Ø	0.80	200	78	8
VT33CT	60 k	120 k	180 k	60 k	1 M	5	0.70 – 1.30	3	0.90	200	35	5

See page 13 for notes.

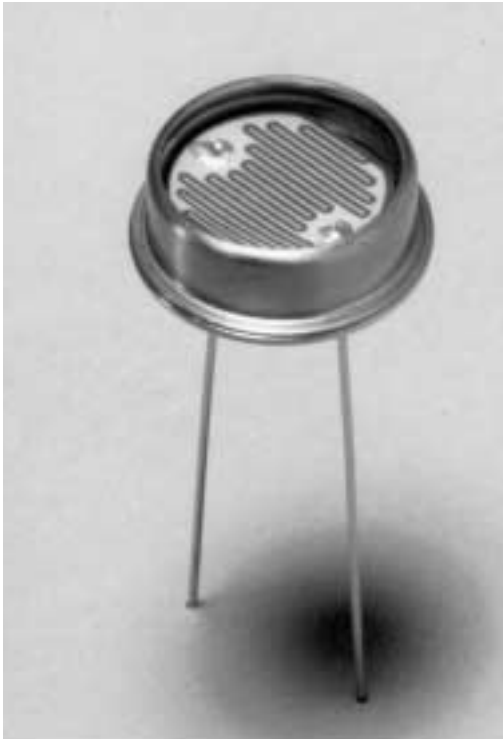

PACKAGE DIMENSIONS inch (mm)

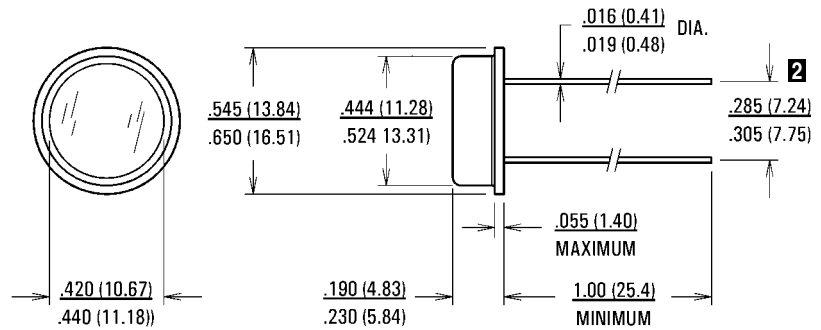

ABSOLUTE MAXIMUM RATINGS

Parameter	Symbol	Rating	Units
Continuous Power Dissipation Derate Above 25°C	P_D $\Delta P_D / \Delta T$	500 10	mW mW/°C
Temperature Range Operating and Storage	T_A	-40 to +75	°C

ELECTRO-OPTICAL CHARACTERISTICS @ 25°C (16 hrs. light adapt, min.) 4

Part Number	Resistance (Ohms) 3 6						Material Type	Sensitivity (γ , typ.) $\frac{OG(R_{10}/R_{100})}{LOG(100/10)}$	Maximum Voltage (V, pk)	Response Time @ 1 fc (ms, typ.)	
	10 lux 2850 K			2 fc 2850 K	Dark					Rise (1-1/e)	Fall (1/e)
	Min.	Typ.	Max.	Typ.	Min.	sec.					
VT50N1	4 k	8 k	12 k	4 k	200 k	5	Ø	0.75	200	78	8
VT50N2	8 k	16 k	24 k	8 k	500 k	5	Ø	0.75	200	78	8
VT50N3	16 k	32 k	48 k	16 k	1 M	5	Ø	0.80	300	78	8
VT53N1	16 k	32 k	48 k	16 k	1 M	5	3	0.85	200	35	5
VT53N2	32 k	76 k	96 k	38 k	2 M	5	3	0.85	200	35	5
VT53N3	66 k	132 k	200 k	66 k	3 M	5	3	0.85	300	35	5

See page 13 for notes.

Application Notes—Photoconductive Cells

APPLICATION NOTE #1

Light - Some Physical Basics

Light is produced by the release of energy from the atoms of a material when they are excited by heat, chemical reaction or other means. Light travels through space in the form of an electromagnetic wave.

A consequence of this wave-like nature is that each “color” can be completely defined by specifying its unique wavelength. The

wavelength is defined as the distance a wave travels in one cycle. Since the wavelengths of light are very short they are normally measured in nanometers, one nanometer being equal to 1×10^{-9} meters.

The spectral response of PerkinElmer’s photoconductors are specified by lots of relative response versus wavelength (color) for various material types.

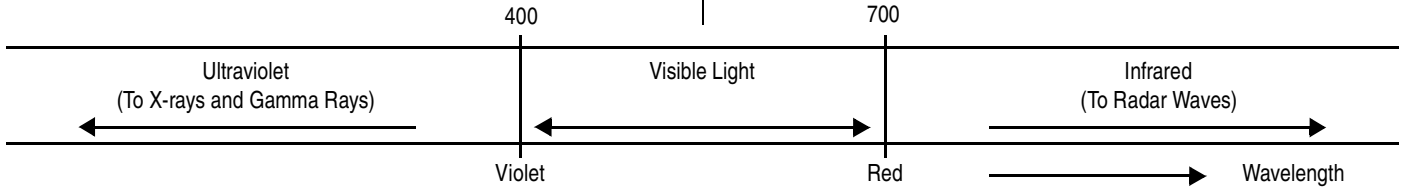

Violet	Below 450 nm
Blue	450 - 500 nm
Green	500 - 570 nm
Yellow	570 - 590 nm
Orange	590 - 610 nm
Red	610 - 700 nm

Natural Illuminance

Sky Condition	Light Level (Typical)
Direct Sunlight	10000 fc
Overcast Day	1000 fc
Twilight	1 fc
Full Moon	0.1 fc
Clear Night Sky (moonless)	0.001 fc

Room Illumination

Lighting Condition	Light Level (Typical)
Candle - Lit Room	5 fc
Auditorium	10 fc
Classroom	30 fc
Inspection Station	250 fc
Hospital Operating Room	500 - 1000 fc

Application Notes—Photoconductive Cells

APPLICATION NOTE #2

Light Resistance Measurement Techniques

The light resistance or “on” resistance (RON) of a photoconductor cell is defined as the resistance of the cell as measured at a special light level using a light source with a known output spectrum. Furthermore, the cell must be “light adapted” for a specific period of time at an established level of illumination in order to achieve repeatable results.

The industry standard light source used for light resistance measurements is a tungsten filament lamp operating at a color temperature of 2850 K. Specifying the 2850 K color temperature for the light source fixes the spectral output (i.e. the tungsten filament light has fixed amounts of blue, green, red, and infrared light).

For consistency and ease of comparing different cells, PerkinElmer lists light resistance values for its photocells at two standard light levels: 2 fc (footcandles) and at 10 lux. The footcandle is the old, historical unit for measuring light intensity and is defined as the illumination produced when the light from one standard candle falls normally on a surface at a distance of one foot. The lux (the metric unit of light measurement) is the illumination produced when the light from one candle falls normally on a surface of one meter. The conversion between footcandle and lux, is as follows:

$$1.0 \text{ fc} = 10.76 \text{ lux}$$

$$1.0 \text{ lux} = 0.093 \text{ fc}$$

As explained in the section on “Selecting a Photocell”, the “light history” effect necessitates the pre-conditioning of the cell before a light resistance measurement is made. PerkinElmer stores all cells at room temperature for 16 hours minimum at 30 – 50 fc (about 320 - 540 lux) prior to making the test measurement.

Sometimes the design engineer or user does not have access to the precision measurement equipment necessary to determine the light levels or light intensities of the application. Should this prove to be a problem, calibrated photocell samples with individual data can be provided by PerkinElmer.

APPLICATION NOTE #3

Spectral Output of Common Light Sources

Incandescent lamps can be considered as black body radiators whose spectral output is dependent on their color temperature. The sun has approximately the same spectral radiation distribution as that of a black body @ 5900 K. However, as viewed from the surface of the earth, the sun's spectrum contains H₂O and CO₂ absorption bands.

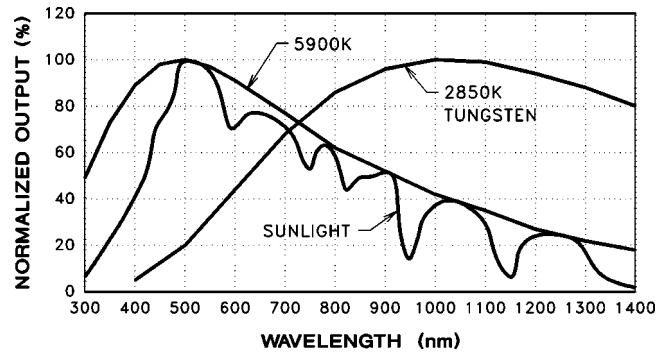

Black Body Sources Output vs. Wavelength

Fluorescent lamps exhibit a broad band spectral output with narrow peaks in certain parts of the spectrum. Shown below is a plot of the light output of a typical daylight type fluorescent tube.

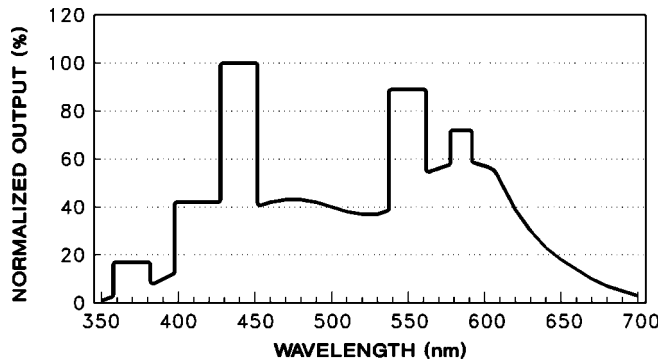

Fluorescent Lamp Output vs. Wavelength

Due to their long operating lifetimes, small size, low power consumption, and the fact they generate little heat, LEDs are the light sources of choice in many applications. When biased in the forward direction LEDs emit light that is very narrow in spectral bandwidth (light of one color). The “color” of the light emitted depends on which semiconductor material was used for the LED.

Application Notes—Photoconductive Cells

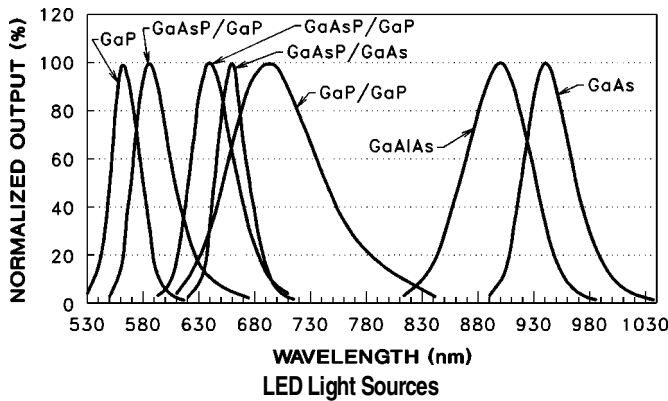

LED Type	Color	λ_p
GaP	GREEN	569 nm
GaAsP/GaP	YELLOW	585 nm
GaAsP/GaP	ORANGE	635 nm
GaAsP/GaAs	RED	655 nm
AlGaAs	RED	660 nm
GaP/GaP	RED	697 nm
GaAlAs	INFRARED	880 nm
GaAs	INFRARED	940 nm

APPLICATION NOTE #4 Spectral Matching of LEDs and Photoconductive Types

Since light sources and light detectors are almost always used together the designer must take into consideration the optical coupling of this system or the ability of the detector to “see” the light source.

In order to have good optical coupling between the emitter and the conductor the spectral output of the light source must, to some degree, overlap the spectral response of the detector. If the design involves the use of a light source with a broad band spectral output the designer is assured that the photocell will have good response to the light. This may not be the case when an LED light source is employed. LEDs emit their light within a very narrow spectral band so that they are often considered to be emitting at only on (peak) wavelength.

Spectral matching factors were calculated for a number of different LEDs and the photoconductor material types manufactured by PerkinElmer. Each matching factor was derived by multiplying the detector response curves by the LED spectral output curve and then measuring the resulting area.

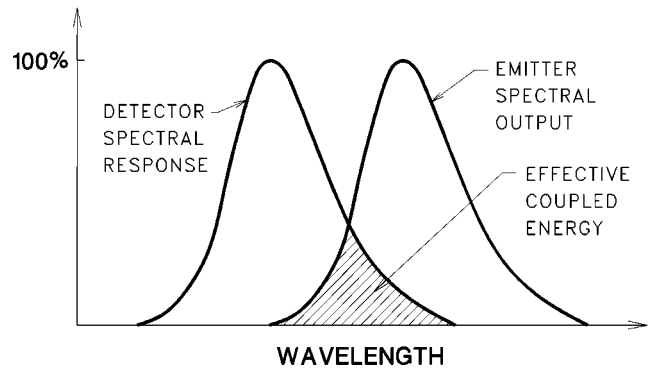

The LED/photocell matching factors listed are independent of power output from the LEDs. In order to get a real feel on how well any LED/photocell pair couple together, the power output from the LED at a particular forward drive current must be considered.

Normalized LED/Photocell Matching

LED Type	λ_p (nm)	Type Ø Material	Type 3 Material
GaP	569	39%	40%
GaAsP/GaP	58	60%	52%
GaAsP/GaP	635	49%	38%
GaAsP/GaAs	655	31%	27%
AlGaAs	66	31%	27%
GaP/GaP	697	47%	31%
GaAlAs	880	—	—
GaAs	940	—	—

The intensity of the light being emitted by visible LEDs is often given in units of millicandela. Millicandela is photometric unit of measure which assumes the human eye as the detector. For most detectors other than the human eye the most convenient system for measurement is the radiometric system. Listed below is the typical light power output of some LEDs measured at two different forward drive currents. Note that LEDs of a given type can show a 5:1 manufacturing spread in power outputs.

LED Type	Color	λ_p (nm)	Power Output	
			$I_f = 1 \text{ mA}$	$I_f = 10 \text{ mA}$
GaP	GREEN	569 nm	1.2 μW	24.1 μW
GaAsP/GaP	YELLOW	585 nm	0.3 μW	26.2 μW
GaAsP/GaP	ORANGE	635 nm	3.2 μW	101.9 μW
GaAsP/GaAs	RED	655 nm	6.2 μW	102.1 μW
AlGaAs	RED	660 nm	33.8 μW	445.1 μW
GaP/GaP	RED	697 nm	54.3 μW	296.2 μW
GaAlAs	INFRARED	880 nm	76.8 μW	1512.3 μW
GaAs	INFRARED	940 nm	35.5 μW	675.0 μW

Application Notes—Photoconductive Cells

Factoring in the power outputs of the LEDs, in this case at a forward drive current of 10 ma, coupling factors (matching factor multiplied by power output) for the various LED/material type combinations can be generated.

Normalized LED/Photocell Coupling Factors @ 10 mA

LED Type	λ_p (nm)	Type Ø	Type 3
GaP	569	3%	3%
GaAsP/GaP	58	5%	5%
GaAsP/GaP	635	17%	13%
GaAsP/GaAs	655	11%	9%
AlGaAs	66	47%	35%
GaP/GaP	697	47%	31%
GaAlAs	880	—	—
GaAs	940	—	—

Once gain, this data is intended as a general guide. LED power outputs can vary 5:1 between manufacturer lots.

APPLICATION NOTE #5 Assembly Precautions

When soldering the cell leads take all measures possible to limit the amount of heating to the photocell. The maximum recommended soldering temperature is 250°C with a solder duration of 5 seconds. Heat sink the LEDs if possible. Keep soldering iron 1/16 inch (1.6 mm) minimum from base of package when soldering.

Avoid chemicals which can cause metal corrosion. Do not clean the plastic coated cells with organic solvents (ketone types). Check with factory for specific cleaning recommendations.

Finally refrain from storing the cells under high temperature and/or humidity conditions. If cells are stored in the dark for any length of time please “light adept” before testing (see section on Light History Effect).

Storage in the dark will change both the sensitivity and decay time of the cell.

APPLICATION NOTE #6 A Low Cost Light Source for Measuring Photocells

The Light Source used in the measurement of photocell resistance must be characterized for intensity and spectral composition. PerkinElmer uses a tungsten filament lamp having a spectral output approximating a black body @ 2850 K with a known candlepower output at a specified voltage and current.

While calibrated lamps of this type are available from the National Institute of Standards and Technology (formerly NBS) and private testing labs, a low cost alternative is to use a 100 W, inside frosted, tungsten filament lamp available from any home or hardware store. Such a lamp operated at 120 VAC will produce approximately 90 candlepower (cp) of illumination and a color temperature of 2700 K to 2800 K.

The relationship between candlepower and footcandle is:

$$\text{footcandle} = \frac{\text{candle power}}{(\text{distance in feet})^2}$$

Since this equation assumes a point source of light, the distance between lamp and detector should be at least five times the lamp diameter.

There are some characteristics of incandescent lamps which should be noted:

1. Color temperature increases with increasing wattage.
2. When operated at a constant current, light output rises with time.

Application Notes—Photoconductive Cells

APPLICATION NOTE #7

How to Specify a Low Cost Photocell

Sometimes the demands of the application such as power dissipation, “on” resistance, voltage, temperature coefficient, etc. limit the selection of the photocell to one particular device. However, more common is the case where any number of photocell types can be used, especially if minor changes are undertaken at an early enough point in the circuit design. In these cases, price is often the deciding factor.

Many factors influence price. In order to give some guidance and weight to these factors the reader is referred to the following table which is meant to serve as a general guide.

Lower Cost	Factor	Higher Cost
Plastic	Packaging	Glass/Metal
Broad	Resistance Range	Narrow
Small	Package Size	Large
Open Order with Scheduled Releases	Scheduling	Released Orders
Standard Tests	Testing	Special Tests

Analog Optical Isolators VACTROLS®

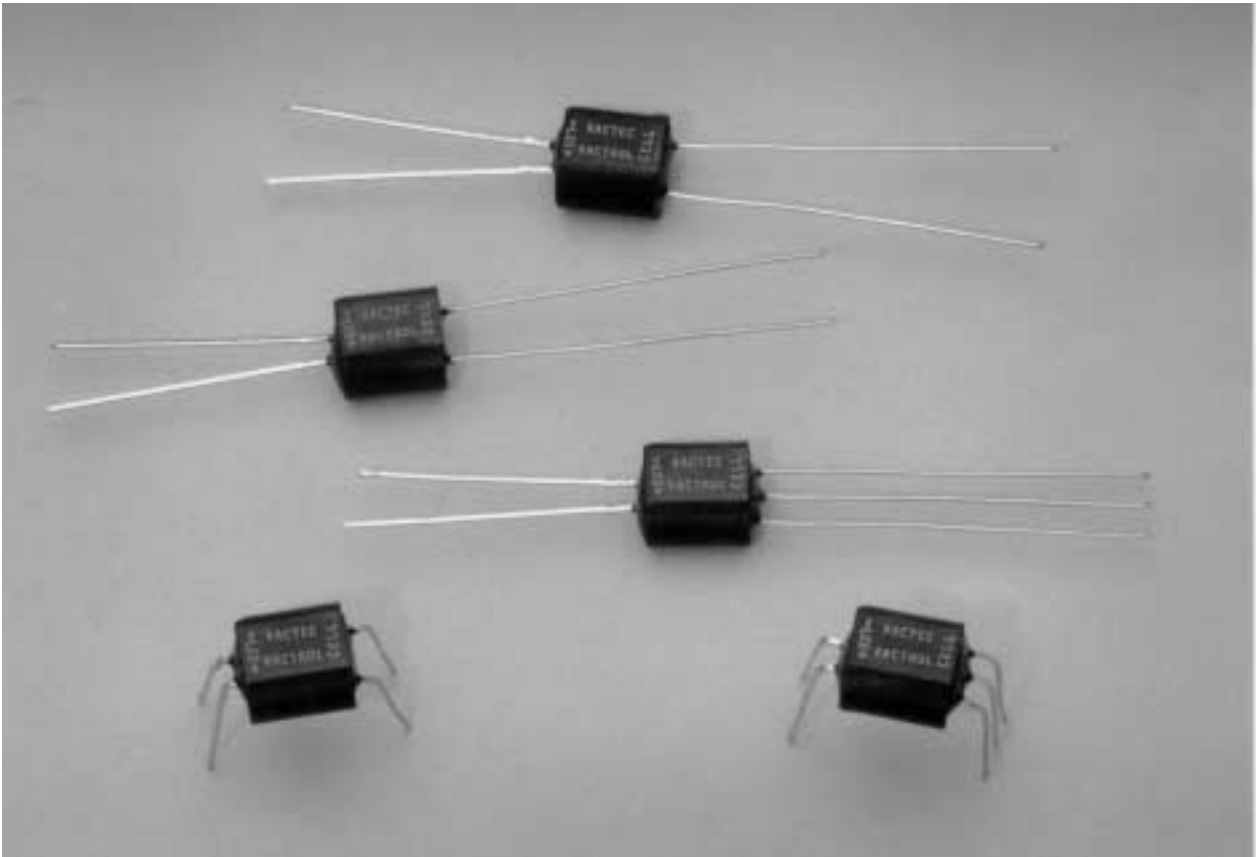

What Are Analog Optical Isolators?

PerkinElmer Optoelectronics has been a leading manufacturer of analog optical isolators for over twenty years and makes a broad range of standard parts under its trademark VACTROL®.

There are many kinds of optical isolators, but the most common is the LED/phototransistor type. Other familiar types use output elements such as light sensitive SCRs, Triacs, FETs, and ICs. The major application for these silicon based devices is to provide electrical isolation of digital lines connected between different pieces of equipment. The principle of operation is very simple. When an input current is applied to the LED, the output phototransistor turns on. The only connection between the LED and phototransistor is through light—not electricity, thus the term optical isolator. These optical isolators are primarily digital in nature with fast response times suitable for interfacing with logic gates. Rise and fall times of a few microseconds, faster for some isolators, are typical.

The analog optical isolator (AOI) also uses an optical link between input and output. The input element is an LED and the output element is always photoconductive cell or simply photocell. Together, the coupled pair act as an electrically variable potentiometer. since the output element of the AOI is a resistor, the voltage applied to this output resistor may be DC and/or AC and the magnitude may be as low as zero or as high as the maximum voltage rating. Because the input will control the magnitude of a complex waveform in a proportional manner, this type of isolator is an analog control element. AOIs may be used in the ON-OFF mode but the fastest response time is only in the millisecond range. A level sensitive Schmitt trigger is required between the AOI and logic gates when used in digital circuits. The figure below shows the circuit diagram of a standard AOI.

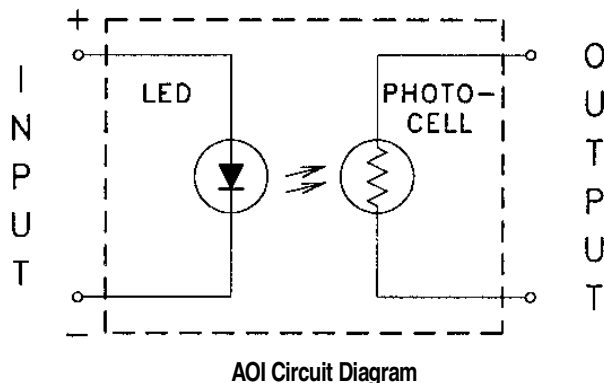

Input Element

Light emitting diodes used in AOIs are usually visible LEDs best matching the sensitivity spectrum of the photocell output element. LEDs are the ideal input element in most applications. They require low drive current and voltage, respond very fast and have virtually unlimited life. They are very rugged and are unaffected by shock and vibration. Since the LED is a diode, it conducts in one direction only.

They must be protected from excessive forward current due to the low dynamic resistance in the forward direction. The forward characteristic of an LED typically used in VACTROLS is shown below.

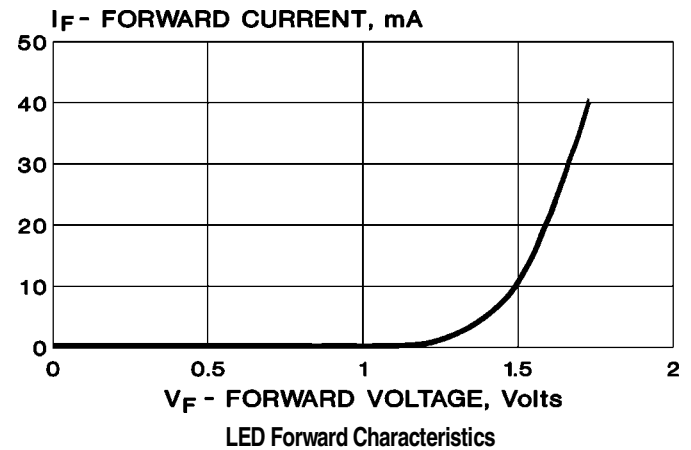

Output Element

The output element in all PerkinElmer's AOIs is a light dependent resistor (LDR), also called a photoconductor or photocell. Photocells are true resistors.

These passive resistors are made from a light sensitive polycrystalline semiconductor thin film which has a very high electron/photon gain. There are no P/N junctions in a photocell, making it a bilateral device.

The resistance of the photocell depends on the amount of light falling on the cell. For a given illumination, the amount of electrical current through the cell depends on the voltage applied. This voltage may be either AC or DC. Thus, the photocell is the ideal low distortion output element for an analog optoisolator.

A complete discussion of photoconductive cells can be found in the first section of this book.

What Are Analog Optical Isolators?

Light History Considerations

Photoconductive cells exhibit a phenomenon known as hysteresis, light memory, or light history effect. Special consideration must be given to this characteristic in the analog optoisolator because the photoconductive element is normally in the dark. This will lead to having the photocell initially in a "dark adapted" state in many conditions.

The light levels that are seen by the photocell in many analog optoisolator applications are quite low, ranging from 0.1 to 1.0 fc. The effect of this combination of dark adapt and low light levels will be seen in the following table.

The table shows the relationship between light history and light resistance at various light levels for different material types. The values shown were determined by dividing the resistance of a given cell, following "infinite" light history (R_{LH}), by the resistance of the same cell following infinite dark history (R_{DH}). For practical purposes, 24 hours in the dark will achieve R_{DH} or 24 at approximately 30 fc will achieve R_{LH} .

Variation of Resistance with Light History Expressed as a Ratio R_{LH}/R_{DH} at Various Test Illumination Levels

Material Type	Illumination (fc)				
	0.01	0.1	1.0	10	100
Type Ø	1.60	1.40	1.20	1.10	1.10
Type 1	5.50	3.10	1.50	1.10	1.05
Type 2	1.50	1.30	1.20	1.10	1.10
Type 3	1.50	1.30	1.20	1.10	1.10
Type 4	4.50	3.00	1.70	1.10	1.10
Type 7	1.87	1.50	1.25	1.15	1.08

The table illustrates the fact that the resistance of a photocell can increase substantially as it transitions from dark adapted state to a light adapted state. The table shows that the Type 1 photocell can increase resistance by a factor of more than three times as it light adapts up to 0.1 fc. In some applications, this can be an important consideration. In general, the magnitude of this effect is larger for types 1, 4, and 7 than for types Ø, 2, and 3.

Each specific material type represents a tradeoff between several characteristics. Selecting the best material is a process of determining what characteristics are most important in the application. The chart gives some appreciation for the general interrelationships between the material types and their properties.

What Are Analog Optical Isolators?

Material Characteristics (General Trends)				
Types 2 & 3	Type 0	Type 7	Type 4	Type 1
Lower	←	Temperature Coefficient	→	Higher
Higher	←	Sheet Resistivity	→	Lower
Slower	←	Speed of Response	→	Faster
Lower	←	Resistance Slope	→	Higher
Smaller	←	Light History Effect	→	Larger

Relative Resistance vs. Temperature

Type 0 Material

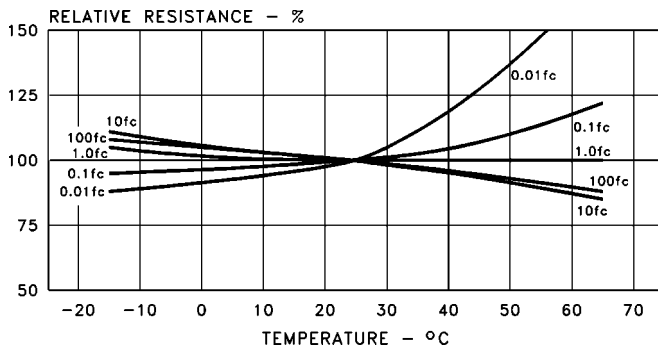

Relative Resistance vs. Temperature

Type 2 Material

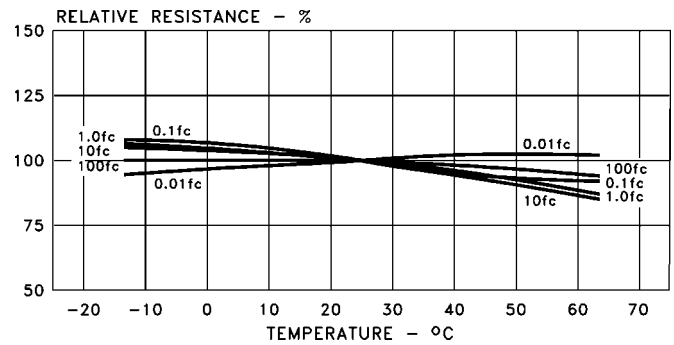

Relative Resistance vs. Temperature

Type 1 Material

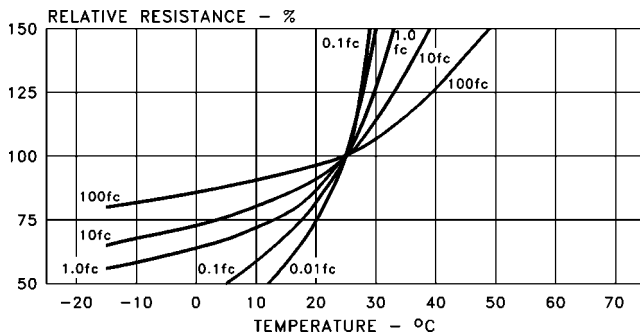

Relative Resistance vs. Temperature

Type 3 Material

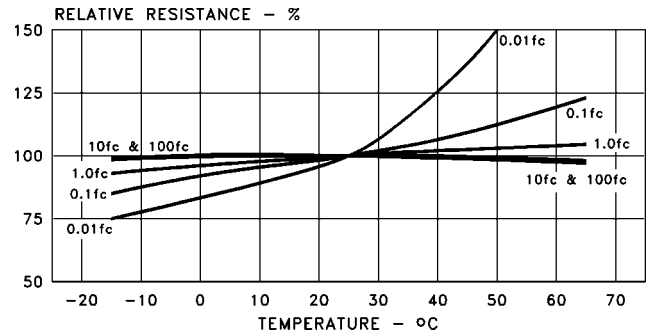

What Are Analog Optical Isolators?

Relative Resistance vs. Temperature

Type 4 Material

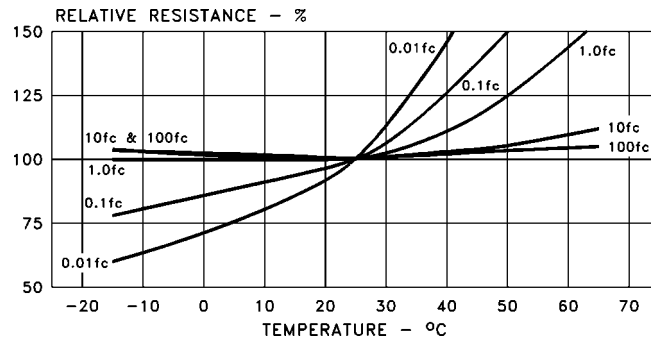

Relative Resistance vs. Temperature

Type 7 Material

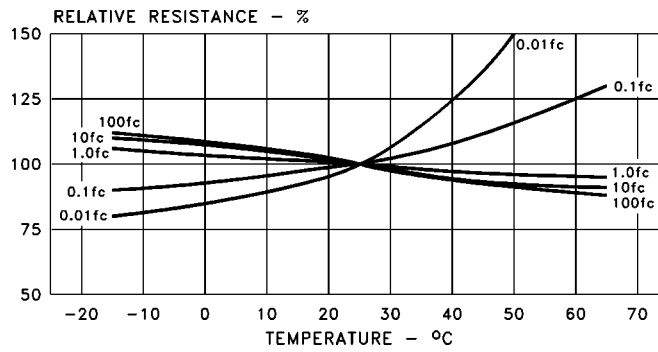

Typical Applications of Analog Optical Isolators

Why Use Analog Optical Isolators?

PerkinElmer Optoelectronics' line of analog optical isolators (AOIs) consists of a light tight package which houses a light source and one or more photoconductive cells. Through control of the input current or voltage applied to the AOI, the output resistance can be varied. The output resistance can be made to switch between an "on" and "off" state or made to track the input signal in an analog manner. Because a small change in input signal can cause a large change in output resistance, AOIs have been found to provide a very economic and technically superior solution for many applications. Their general characteristics and salient features can be summarized as follows:

- *High input-to-output voltage isolation*
- *True resistance element output*
- *Single or dual element outputs available*
- *Low cost*
- *Suitable for AC or DC use*
- *Wide range of input to output characteristics*
- *Low drive current*
- *Low "on" resistance, high "off" resistance*
- *Complete solid-state construction*

Applications

Analog Optical Isolators are used in many different types of circuits and applications. Here is a list of only a few examples of where AOIs have been used.

- *DC isolators*
- *Feedback elements in automatic gain control circuits*
- *Audio limiting and compression*
- *Noiseless switching*
- *Logic interfacing*
- *Remote gain control for amplifiers*
- *Photochoppers*
- *Noiseless potentiometers*

Typical Applications of Analog Optical Isolators

Typical Application Circuits

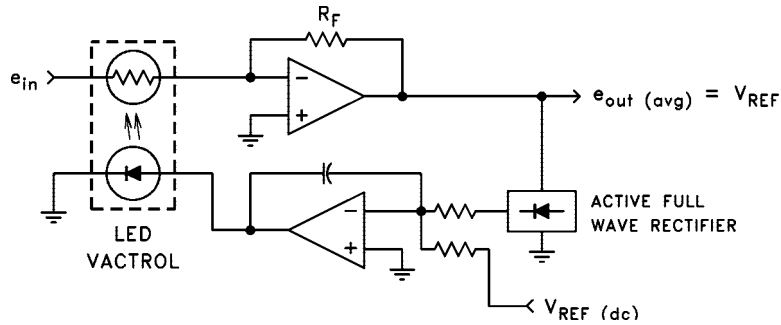

Automatic Gain Control (AGC)

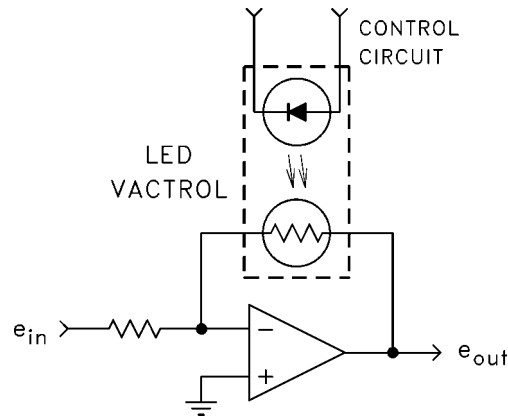

Remote Gain Control

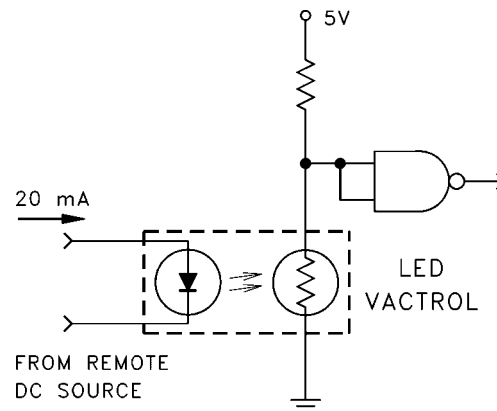

Noiseless Switching/Logic Interfacing

(See Application Note #1)

Audio Applications

Characteristics of Analog Optical Isolators

Transfer Characteristics

The light output of an LED is proportional to the input drive current, I_F . Some LEDs will begin to radiate useful amounts of light output at forward currents as low as 10 μ A. These same LEDs can be driven at 50 mA with no degradation in performance.

A transfer curve of output resistance versus input light current for a typical AOI is shown in Figure 1. AOIs not only possess a large dynamic range, but the output resistance tracks the input current in a somewhat linear manner over a range of two or more decades.

This characteristic makes the AOI suitable for use in a very broad range of applications, especially in audio circuits where they are used for switching, limiting, and gating. For a more extensive discussion on AOIs in audio circuits, refer to Application Notes #1.

Response Time

AOIs are not high speed devices. Speed is limited by the response time of the photocell. With rise and fall times on the order of 2.5 to 1500 msec, most AOIs have bandwidths between 1 Hz and 200 Hz.

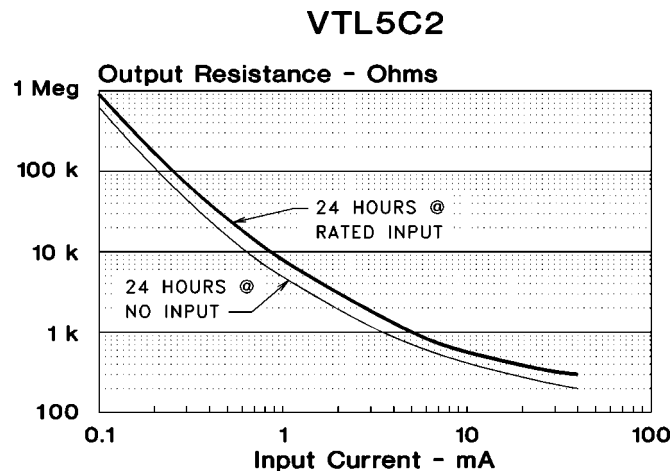

Figure 1. Transfer Curves (25°C)

One of the characteristics of photocells is that their speed of response increases with increasing levels of illumination.¹ Thus the bandwidth of Vactrols is somewhat dependent upon the input drive level to the LED. In general, the higher the input drive the wider the bandwidth.

The turn-off time and turn-on time of photocells are not symmetrical. The turn-on time can be an order of magnitude faster than the turn-off time. In the dark (no input), the resistance of the cell is very high, typically on the order of several megohms. When light is suddenly

applied, the photocells resistance drops very fast, typically reaching 63% (1-1/e conductance) of its final values in under 10 msec.

When the light is removed, the resistance increases initially at an exponential rate, approximately tripling in a few milliseconds. The resistance then increases linearly with time.

The fast turn-on and slow turn-off characteristics can be used to advantage in many applications. This is especially true in audio applications where a fast turn-on (attack) and a slow turn-off (release) is preferred. For example, the typical AOI can be made to turn-on in 100 to 1000 μ sec. In a limited circuit this is fast enough to catch high peak amplitudes but not so fast as to cause obvious clipping. The turn-off will take as much as 100 times longer so the audio circuit will return to a normal gain condition without a disturbing "thump" in the speaker.

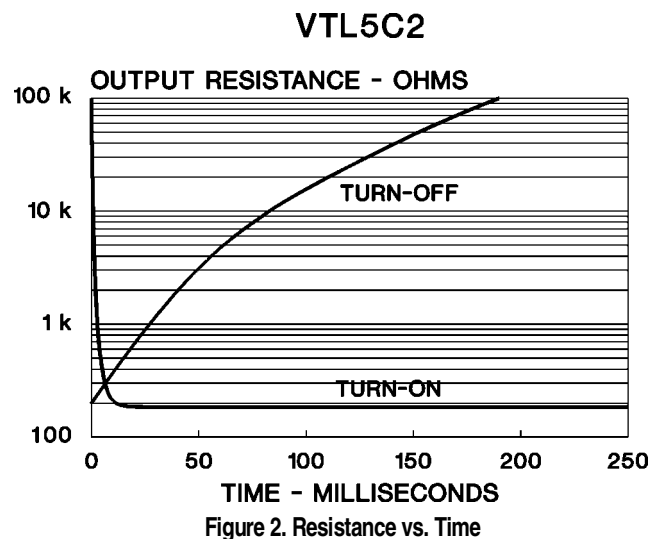

Figure 2. Resistance vs. Time

Noise

The sources of electrical noise in the output element of AOIs are the same as for any other type of resistor.

One source of noise is thermal noise, also known as Johnson or "white" noise, which is caused by the random motion of free electrons in the photoconductive material.

1. For a more comprehensive discussion on the turn-on and turn-off characteristics of photocells and how response time is affected by light level, see the Photoconductive Cell section of this catalog.

Characteristics of Analog Optical Isolators

Some major characteristics of Johnson noise are that it is:

1. Independent of frequency and contains a constant power density per unit of bandwidth.
2. Temperature dependent, increasing with increased temperature.
3. Dependent on photocell resistance value.

Johnson noise is defined by the following equation:

$$I_{NJ} = \sqrt{(4kTBW)/R}$$

where:

I_{NJ} = Johnson noise current, amps RMS
 k = Boltzmann's constant, 1.38×10^{-23}
 T = temperature, degrees Kelvin
 R = photocell resistance
 BW = bandwidth of interest, Hertz

A second type of noise is "shot" noise. When a direct current flows through a device, these are some random variations superimposed on this current due to random fluctuations in the emission of electrons due to photon absorption. The velocity of the electrons and their transit time will also have an effect.

"Shot" noise is:

1. Independent of frequency.
2. Dependent upon the direct current flowing through the photocell.

Shot noise is defined by the following equation:

$$I_{NS} = \sqrt{2eI_{dc}BW}$$

where:

I_{NS} = shot noise current, amps RMS
 e = electron charge, 1.6×10^{-19}
 I_{dc} = dc current, amps
 BW = bandwidth of interest, Hertz

The third type of noise is flicker or $1/f$ noise. The source of $1/f$ noise is not well understood but seems to be attributable to manufacturing noise mechanisms. Its equation is as follows:

$$I_{NF} = \sqrt{KI_{dc}BW}/f$$

where:

I_{NF} = flicker noise, amps
 K = a constant that depends on the type of material and its geometry
 I_{dc} = dc current, amps
 BW = bandwidth of interest, Hertz
 f = frequency, Hertz

Unlike thermal or shot noise, flicker noise has $1/f$ spectral density and in the ideal case for which it is exactly proportional to $\sqrt{1/f}$, it is termed "pink noise". Unfortunately, the constant (K) can only be determined empirically and may vary greatly even for similar devices. Flicker noise may dominate when the bandwidth of interest contains frequencies less than about 1 kHz.

In most AOI circuits noise is usually so low that it is hardly ever considered. One notable exception is in applications where large voltages are placed across the cell. For a typical isolator, it takes 80 to 100V across the photocell before the noise level starts to increase significantly.

Distortion

Analog Optical Isolators have found wide use as control elements in audio circuits because they possess two characteristics which no other active semiconductor device has: resistance output and low harmonic distortion. AOIs often exhibit distortion levels below -80 db when the voltage applied to the photocell output is kept below 0.5V.

Figure 3 shows the typical distortion generated in typical AOIs. The distortion depends on the operating resistance level as well as the applied voltage. The minimum distortion or threshold distortion shown in Figure 3 is a second harmonic of the fundamental frequency. The actual source of this distortion is unknown, but may be due to some type of crossover nonlinearity at the original of the I-V curve of the photocell.

Characteristics of Analog Optical Isolators

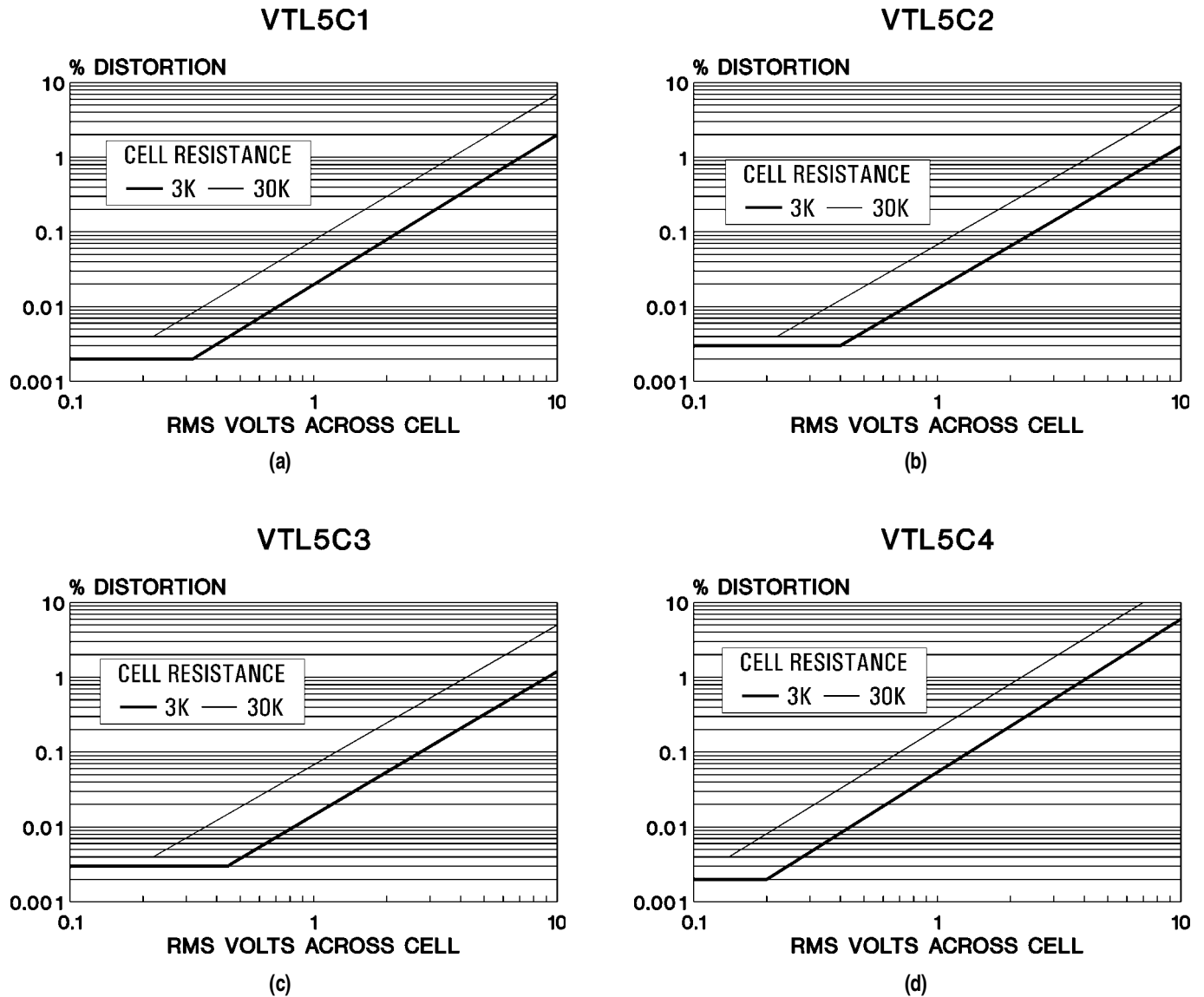

Figure 3. Typical LED AOI Distortion Characteristics

At high AC voltages, distortion to the waveform can be seen using an oscilloscope. The waveform is still symmetrical but contains the fundamental and the odd harmonics, the third harmonic being predominant. If there is DC as well as AC voltage on the photocell, both even and odd harmonics are generated.

The RMS value of voltage or current is not very sensitive to a large third harmonic component, but the instantaneous value is. A 10% harmonic will only change the RMS values by 0.5%. If the output is used to control a thermal element, such as a thermal relay, circuit operation is not affected. Further, when the AOI is used in ON-OFF applications, waveform distortion is not a problem.

Characteristics of Analog Optical Isolators

Voltage Rating

The maximum voltage rating of the output element (photocell) applies only when the input is off. Two different kinds of dark current "leakage" characteristics are observed in photocell output elements. Figure 4 shows the soft breakdown found in lower resistivity materials. With no input, if the applied voltage is suddenly increased from zero to V_1 , the current increases along section 'a', with the steepness depending on the rate at which the voltage is increased. If the voltage is now held at V_1 , the current decreases along curve 'b' and stabilizes at a much lower value. If the voltage is again increased, the next section of the curve is traversed with the current dropping along curve 'd' in time. This process can be repeated until the reverse current becomes so great that the cell burns up. The maximum voltage rating for photocells with this soft reverse characteristic is based on a safe steady-state power dissipation in the OFF condition.

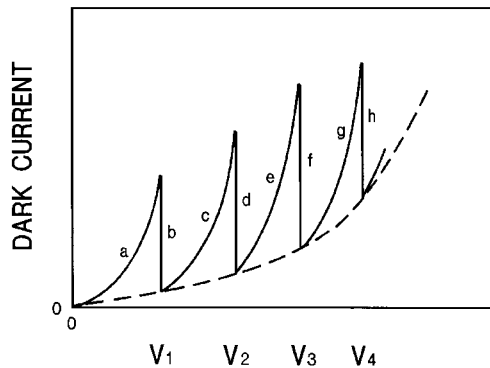

Figure 4. Breakdown characteristics of photocells with low resistivity photoconductive material.

Higher resistivity photoconductive materials do not show the reverse characteristics of Figure 4 to any significant degree. As voltage is increased, the dark current increases, but remains very low until breakdown occurs. The current then increases in an avalanche fashion resulting in an arc-over which causes the cell to be permanently damaged (shorted). The dielectric breakdown voltage is approximately 8 - 10 kV per cm of contact spacing for materials with this type of reverse characteristic. Photocells have 0.16 - 0.5 mm electrode spacing so the maximum voltage ratings typically fall into the 100 - 300 volt range.

The high voltage capability of photocells suggests their use as the series pass element in a high voltage regulated power supply. Voltages up to 5 or 10 kV can be regulated but the current should be limited to 1 or 2 mA. The isolated input element greatly simplifies the circuit design and the single output element avoids the need for voltage and current sharing components.

Power Rating

Photocells are primarily used for signal control since the maximum allowable power dissipation is low. Typically, the steady-state output current should be kept below 10 mA on catalog LED AOIs because of the small size ceramic used in the output cell. However, the surface area is large compared to similarly rated transistors, so AOIs withstand significant transient current and power surges.

Power ratings are given in the catalog and are typically a few hundred milliwatts, but special AOIs have been made with power dissipation ratings as high as 2.0 W.

Life and Aging

Life expectancy of an AOI is influenced both by the input and output devices. Isolators which use an LED have long life since LED lifetimes are long: 10,000 to 200,000 hours, depending on the application. LEDs normally show a decrease in light output for a specified bias current as they age.

The photocell output elements in AOIs show an increase in output resistance over time as they age. With a continuous input drive current and with voltage bias applied to the output, the output resistance will generally increase at a rate of 10 percent per year. The aging rate is lower with intermittent operation. Figure 5 shows the trend line for output resistance under typical operating conditions. Other AOIs using different photoconductive materials show similar trends.

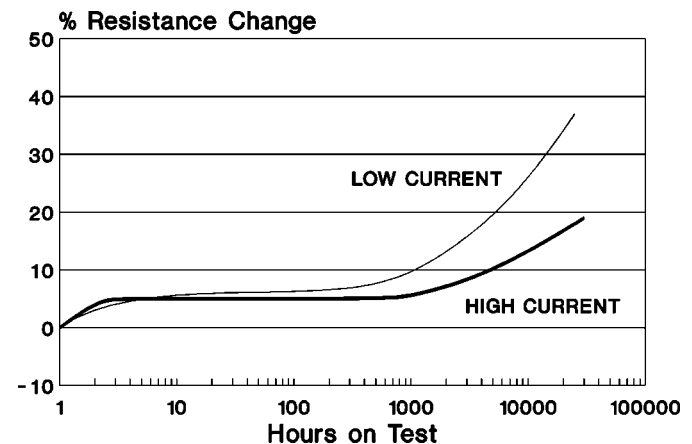

Figure 5. VTL5C3 Life Test.

Characteristics of Analog Optical Isolators

Storage Characteristics

The instantaneous output resistance of any AOI is somewhat dependent on the short term light history of the photocell output element. With no applied input current or voltage, the output element is in the dark. Dark storage causes the cell to “dark adapt”, a condition which results in an increase in the photocell’s sensitivity to light. When first turned on, an AOI which has experienced a period of dark adaptation will exhibit a lower value for “on” resistance, at any given drive condition, than the same device which has been continuously on.

The output resistance of an AOI which has been biased “on” is considered to be constant with time (neglecting long term aging effects). After the removal of the input drive, the photocell begins to experience dark adaptation. The cell’s rate of increase in sensitivity is initially high but eventually levels off with time in an exponential manner. Most of the dark adapt occurs in the first eight hours, but with some AOIs for sensitivity can continue to increase for several weeks. When an AOI which has been sitting in the dark is turned on, the cell immediately begins returning to its light adapted state. For any given device, the rate of recovery is dependent on the input light level.

The type of photoconductive material is the major factor determining the magnitude of these changes. Lower resistivity materials show greater initial and final changes but their rate of change is faster.

These light/dark history effects are pronounced at both high and low input levels. However, at high input levels, the photocell light adapts quite rapidly, usually in minutes.

Figure 1 shows the transfer curves for an AOI after 24 hour storage with no input and then after it has been operated with rated input for 24 hours. Because of these “memory” phenomena, it is best to use these parts in a closed loop circuit to minimize the effects of these changes. Open loop proportional operation is possible if the application can tolerate variations. The use of the VTL5C2 and VTL5C3 with their more stable characteristics will help.

Temperature Range

Operating and storage temperature range is limited at the lower end by the reduction of dark resistance of the cell and at the upper end by rapid aging. At low temperatures, the response time of the output cell increases. The temperature at which this becomes pronounced depends on the photoconductive material type. Isolators using low resistivity materials, as in the VTL5C4, will show this lengthening of response time at -25°C. Higher resistivity materials such as used in the VTL5C3 and VTL5C6 do not slow down excessively until temperatures get below -40°C. This characteristic is completely reversible with the response time recovering when the temperature rises.

Storage at low temperature has no operating effect on AOIs. Units may be stored at temperatures as low as -40°C. Lower temperatures may cause mechanical stress damage in the package which can cause permanent changes in the AOI transfer characteristics.

The chemistry of the photoconductive materials dictates a maximum operating and storage temperature of 75°C. It should be noted that operation of the photocell above 75°C does not usually lead to catastrophic failure but the photoconductive surface may be damaged, leading to irreversible changes in sensitivity.

The amount of resistance change is a function of time as well as temperature. While changes of several hundred percent will occur in a matter of a few minutes at 150°C, it will take years at 50°C to produce that much change.

In most applications, operation is intermittent. At elevated temperatures, the resistance of the cell rises during the turn-on period and recovers during the turn-off period, usually resulting in little net change. However, if the AOI is stored at elevated temperatures for many hours with no input signal, there is a net reduction in output resistance. There will be some recovery during operation over time but it is not possible to predict the rate or to what degree. Elevated temperatures do not produce sudden catastrophic failure, but changes in the device transfer curve with time must be anticipated.

Characteristics of Analog Optical Isolators

Capacitance

The equivalent circuit for the output photocell is a resistor in parallel with the capacitance. The capacitance arises from the topside metallization of the electrodes which form a coplanar capacitor. The value of this capacitance is largely determined by the size of the ceramic base. For lower capacitance, a smaller cell is needed. The capacitance is so small (3.0 pF, typical on catalog AOIs) that it is negligible in most applications. However, there are applications such as wideband or high frequency amplifiers in which the capacitance needs to be considered. At 4.5 MHz, the video baseband frequency, the photocell capacitive reactance is only 12 kilohms. If the phase shift of the signal is to be kept below 10°, the highest useful cell resistance is only 2.0 kilohms. At high AOI input drive, where the cell is drive below 1.0 kilohm, the capacitance can increase additionally from 2 to 10 times, possibly due to distributed effects.

Summary

Analog Optical Isolators have many unique features, such as:

1. High input-to-output isolation.
2. True resistance element output.
3. Wide dynamic range (low "on" resistance/high "off" resistance).
4. Low drive current.
5. Low distortion.

These features are primarily dependent on which input element and output element photoconductive material is used in the Vactrol AOI. Thus, there is a wide variety of Vactrols to choose from for your application.

Characteristics of Analog Optical Isolators

Typical Transfer Characteristics (Resistance vs. Input Current) For Standard Vactrols

Curves shown are based upon a light adapt condition for 24 hours @ no input at 25°C.

Output Resistance vs. Input Current

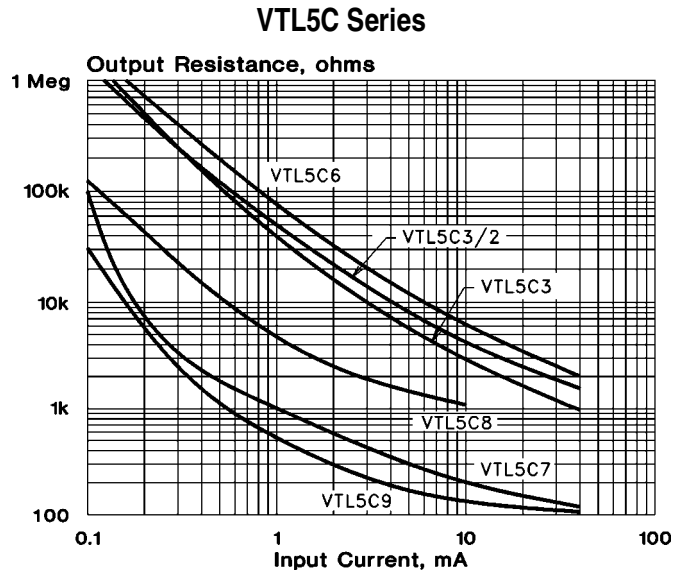

Output Resistance vs. Input Current

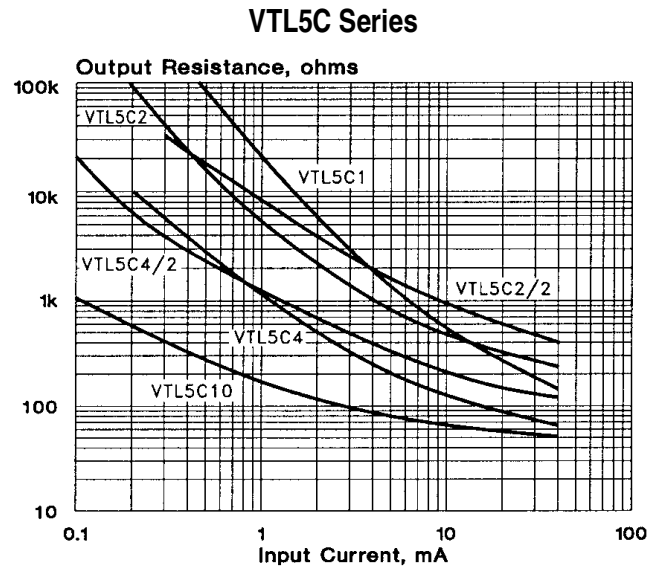

Characteristics of Analog Optical Isolators

Analog Optoisolator Comparison Chart

Device	Material Type	Slope	Dynamic Range	Dark Resistance	Temperature Coefficient	Speed of Response	Light History Effect
VTL5C1	1	15.0	100 db	50 MΩ	Very High	Very Fast	Very Large
VTL5C2	∅	24.0	69 db	1 MΩ	Low	Slow	Small
VTL5C2/2	∅	20.0	65 db	1 MΩ	Low	Slow	Small
VTL5C3	3	20.0	75 db	10 MΩ	Very Low	Very Slow	Very Small
VTL5C3/2	3	19.0	71 db	10 MΩ	Very Low	Very Slow	Very Small
VTL5C4	4	18.7	72 db	400 MΩ	High	Fast	Large
VTL5C4/2	4	8.3	68 db	400 MΩ	High	Fast	Large
VTL5C6	∅	16.7	88 db	100 MΩ	Low	Slow	Small
VTL5C7	7	5.7	75 db	1 MΩ	Average	Average	Average
VTL5C8	∅	8.0	80 db	10 MΩ	Low	Slow	Small
VTL5C9	1	7.3	112 db	50 MΩ	Very High	Very Fast	Very Large
VTL5C10	4	3.8	75 db	400 MΩ	High	Fast	Large

Specification Notes

(These notes are referenced on the following LED Vactrol Data Sheet pages.)

- 1** Since the input has a substantially constant voltage drop, a current limiting resistance is required.
- 2** Dark adapted resistance measured after 24 or more hours of no input.
- 3** Measured 10 sec. after removal of the input. The ultimate resistance is many times greater than the value at 10 seconds.
- 4** Ascent measured to 63% of final conductance from the application of 40 mA input. The conductance rise time to a specified value is increased at reduced input drive while the conductance decay time to a specified value is decreased.
- 5** Typical matching and tracking from 0.4 to 40 mA is 25%.
- 6** Measured 5 sec. after removal of the input. The ultimate resistance is many times greater than the value at 5 seconds.
- 7** VTL5C9 response times are based on a 2.0 mA input. VTL5C10 response times are based on a 10.0 mA input for ascent time and a 1.0 mA input for decay time.

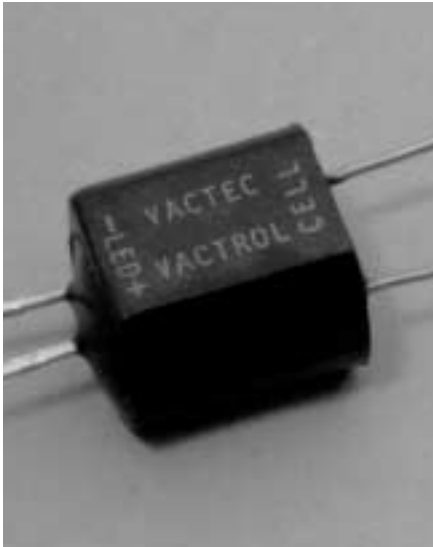

PACKAGE DIMENSIONS inch (mm)

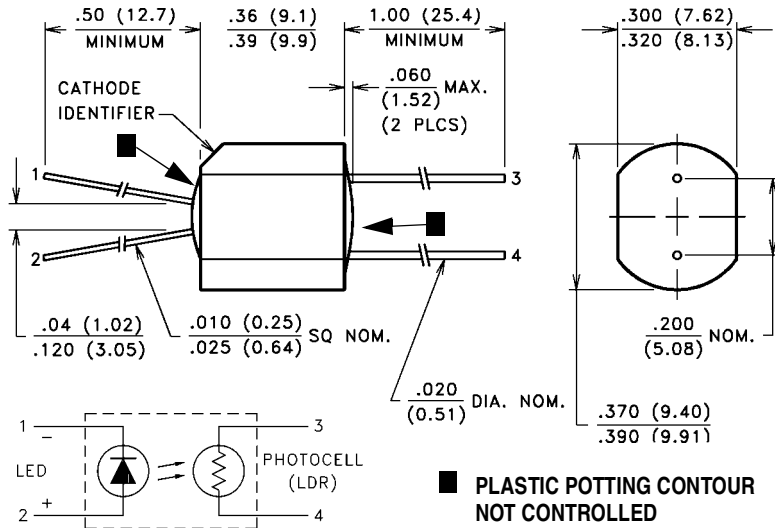

DESCRIPTION

VTL5C1 offers 100db dynamic range, fast response time, and very high dark resistance.
 VTL5C2 features a very steep slope, low temperature coefficient of resistance, and a small light history memory.

ABSOLUTE MAXIMUM RATINGS @ 25°C

Maximum Temperatures		LED Forward Voltage Drop @ 20 mA:	2.0V (1.65V Typ.)
Storage and Operating:	-40°C to 75°C	Min. Isolation Voltage @ 70% Rel. Humidity:	2500 VRMS
Cell Power:	175 mW	Output Cell Capacitance:	5.0 pF
Derate above 30°C:	3.9 mW/°C	Cell Voltage:	100V (VTL5C1), 200V (VTL5C2)
LED Current:	40 mA 1	Input - Output Coupling Capacitance:	0.5 pF
Derate above 30°C:	0.9 mA/°C		
LED Reverse Breakdown Voltage:	3.0 V		

ELECTRO-OPTICAL CHARACTERISTICS @ 25°C

Part Number	Material Type	ON Resistance 2		OFF 3 Resistance @ 10 sec. (Min.)	Slope (Typ.) @ 0.5 mA / R @ 5 mA	Dynamic Range (Typ.) R _{DARK} / R @ 20 mA	Response Time 4	
		Input current	Dark Adapted (Typ.)				Turn-on to 63% Final R _{ON} (Typ.)	Turn-off (Decay) to 100 kΩ (Max.)
VTL5C1	1	1 mA 10 mA 40 mA	20 kΩ 600 Ω 200 Ω	50 MΩ	15	100 db	2.5 ms	35 ms
VTL5C2	0	1 mA 10 mA 40 mA	5.5 kΩ 800 Ω 200 Ω	1 MΩ	24	69 db	3.5 ms	500 ms

Refer to Specification Notes, page 41.

Typical Performance Curves

Output Resistance vs. Input Current
VTL5C1

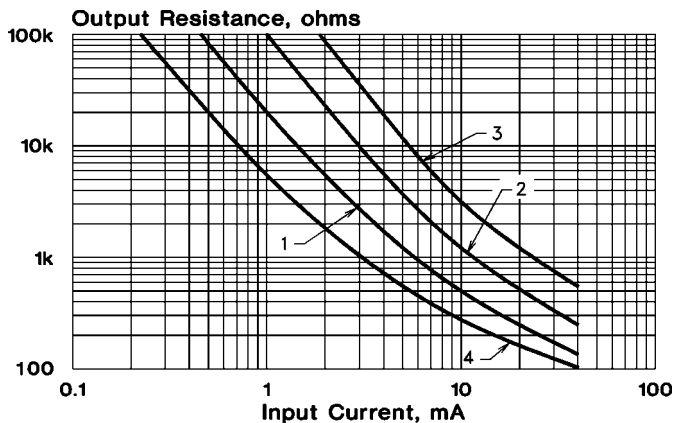

Response Time
VTL5C1

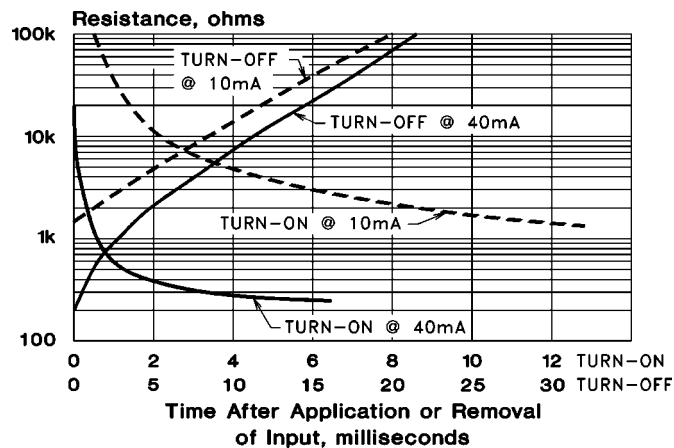

Output Resistance vs. Input Current
VTL5C2

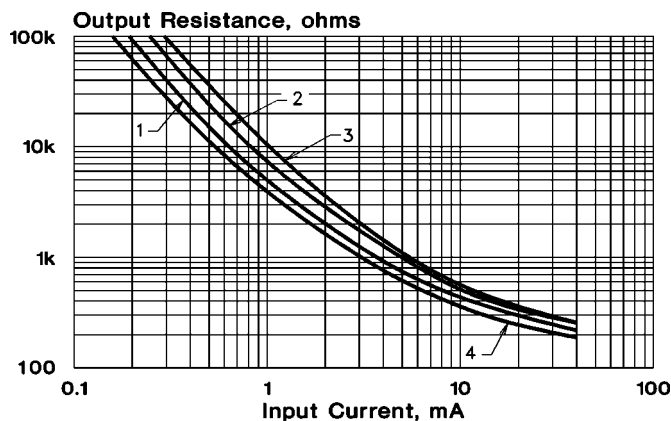

Response Time
VTL5C2

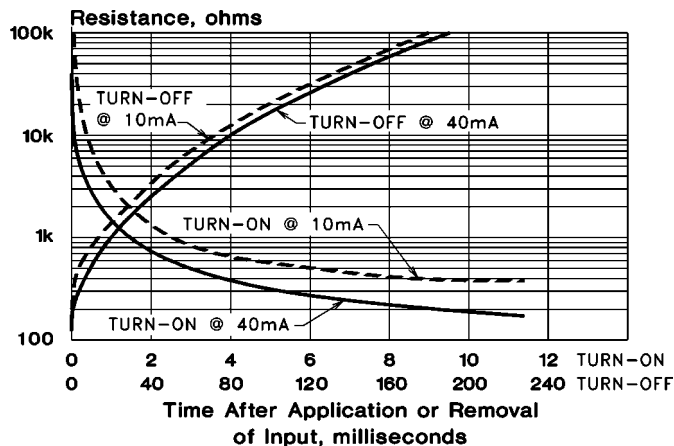

Input Characteristics

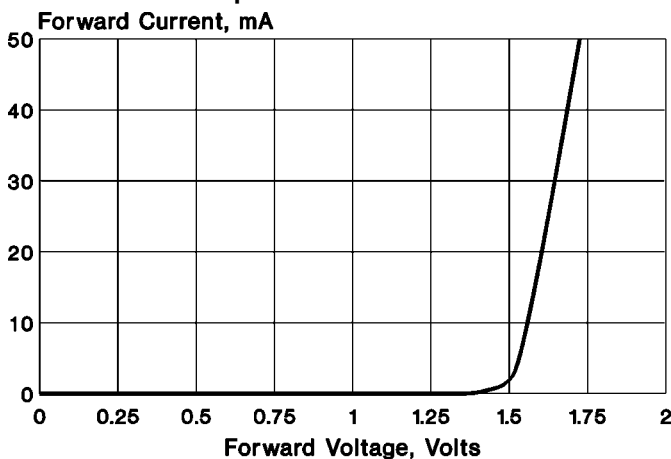

Notes:

- At 1.0 mA and below, units may have substantially higher resistance than shown in the typical curves. Consult factory if closely controlled characteristics are required at low input currents.
- Output resistance vs input current transfer curves are given for the following light adapt conditions:
 - 25°C — 24 hours @ no input
 - 25°C — 24 hours @ 40 mA input
 - +50°C — 24 hours @ 40 mA input
 - 20°C — 24 hours @ 40 mA input
- Response time characteristics are based upon test following adapt condition (2) above.

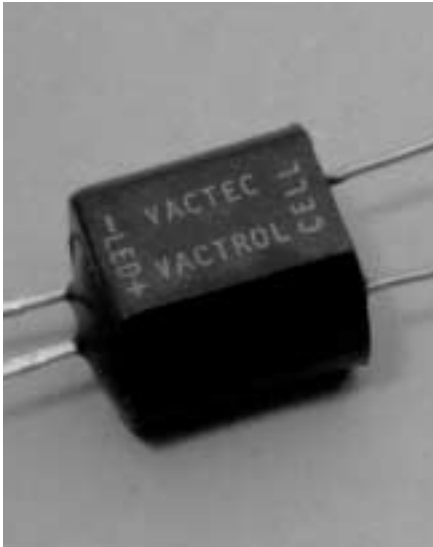

PACKAGE DIMENSIONS INCH (MM)

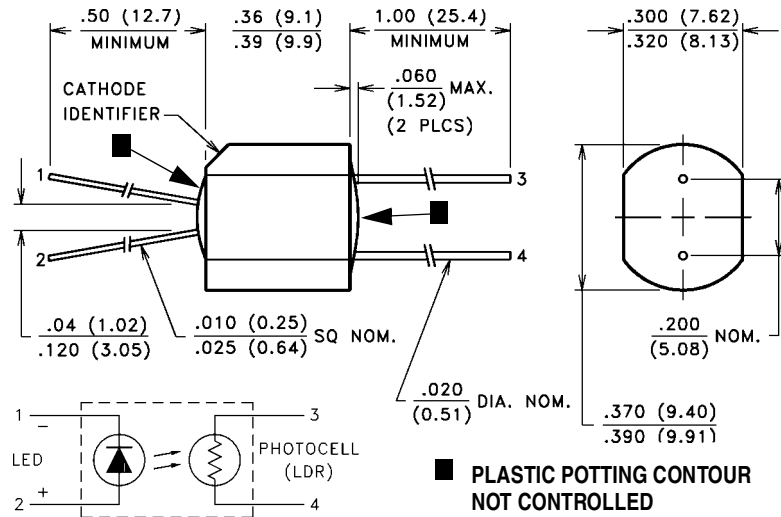

DESCRIPTION

VTL5C3 has a steep slope, good dynamic range, a very low temperature coefficient of resistance, and a small light history memory. VTL5C4 features a very low “on” resistance, fast response time, with a smaller temperature coefficient of resistance than VTL5C1.

ABSOLUTE MAXIMUM RATINGS @ 25°C

Maximum Temperatures		LED Forward Voltage Drop @ 20 mA:	2.0V (1.65V Typ.)
Storage and Operating:	-40°C to 75°C	Min. Isolation Voltage @ 70% Rel. Humidity:	2500 VRMS
Cell Power:	175 mW	Output Cell Capacitance:	5.0 pF
Derate above 30°C:	3.9 mW/°C	Cell Voltage:	250V (VTL5C3), 50V (VTL5C4)
LED Current:	40 mA 1	Input - Output Coupling Capacitance:	0.5 pF
Derate above 30°C:	0.9 mA/°C		
LED Reverse Breakdown Voltage:	3.0 V		

ELECTRO-OPTICAL CHARACTERISTICS @ 25°C

Part Number	Material Type	ON Resistance 2		OFF 3 Resistance @ 10 sec. (Min.)	Slope (Typ.) R @ 0.5 mA R @ 5 mA	Dynamic Range (Typ.) R _{DARK} R @ 20 mA	Response Time 4	
		Input current	Dark Adapted (Typ.)				Turn-on to 63% Final R _{ON} (Typ.)	Turn-off (Decay) to 100 kΩ (Max.)
VTL5C3	3	1 mA 10 mA 40 mA	30 kΩ 5 Ω 1.5 Ω	10 MΩ	20	75 db	2.5 ms	35 ms
VTL5C4	4	1 mA 10 mA 40 mA	1.2 kΩ 125 Ω 75 Ω	400 MΩ	18.7	72 db	6.0 ms	1.5 sec

Refer to Specification Notes, page 41.

Typical Performance Curves

Output Resistance vs. Input Current
VTL5C3

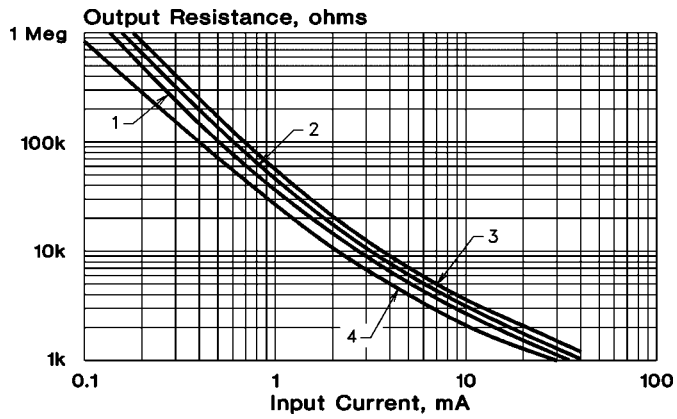

Response Time
VTL5C3

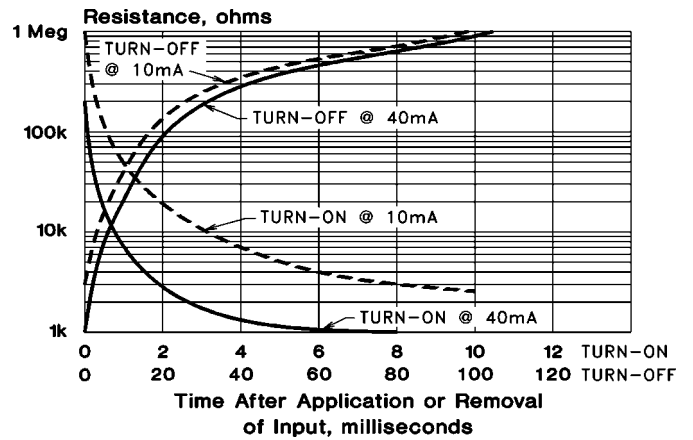

Output Resistance vs. Input Current
VTL5C4

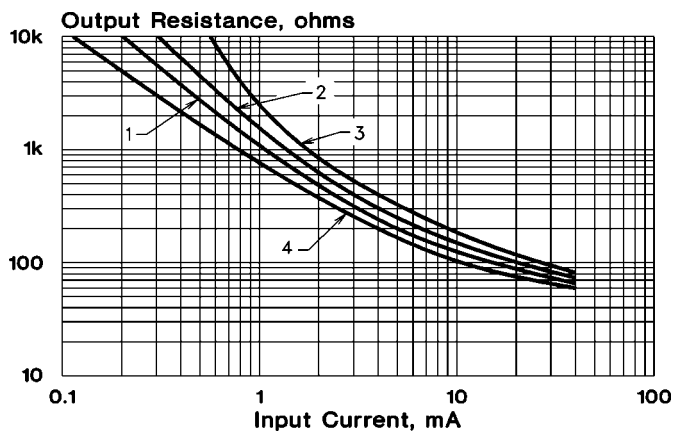

Response Time
VTL5C4

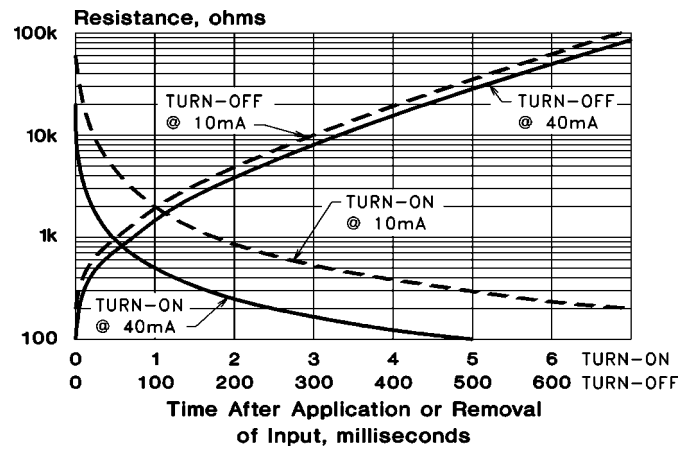

Input Characteristics

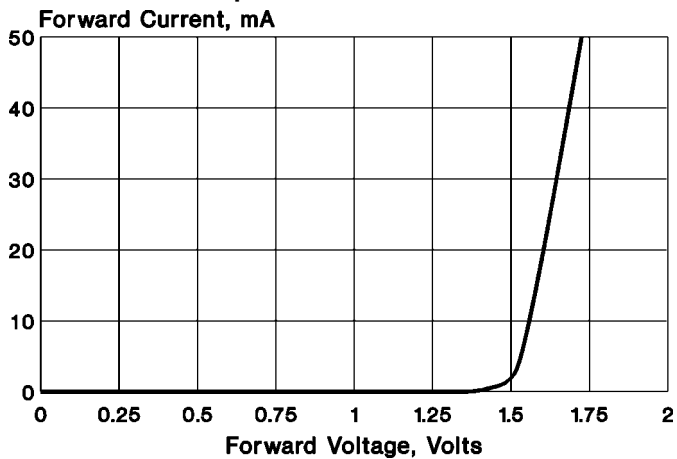

Notes:

- At 1.0 mA and below, units may have substantially higher resistance than shown in the typical curves. Consult factory if closely controlled characteristics are required at low input currents.
- Output resistance vs input current transfer curves are given for the following light adapt conditions:
 - 25°C — 24 hours @ no input
 - 25°C — 24 hours @ 40 mA input
 - +50°C — 24 hours @ 40 mA input
 - 20°C — 24 hours @ 40 mA input
- Response time characteristics are based upon test following adapt condition (2) above.

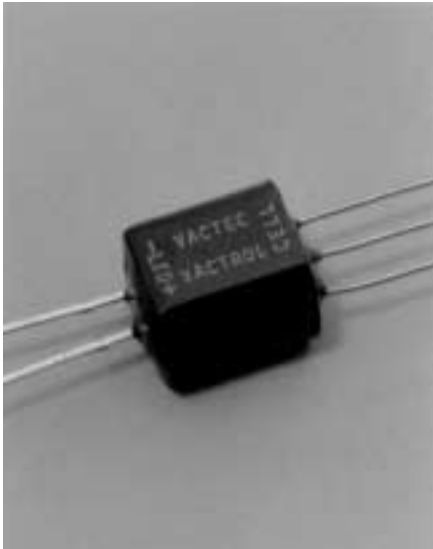

PACKAGE DIMENSIONS INCH (MM)

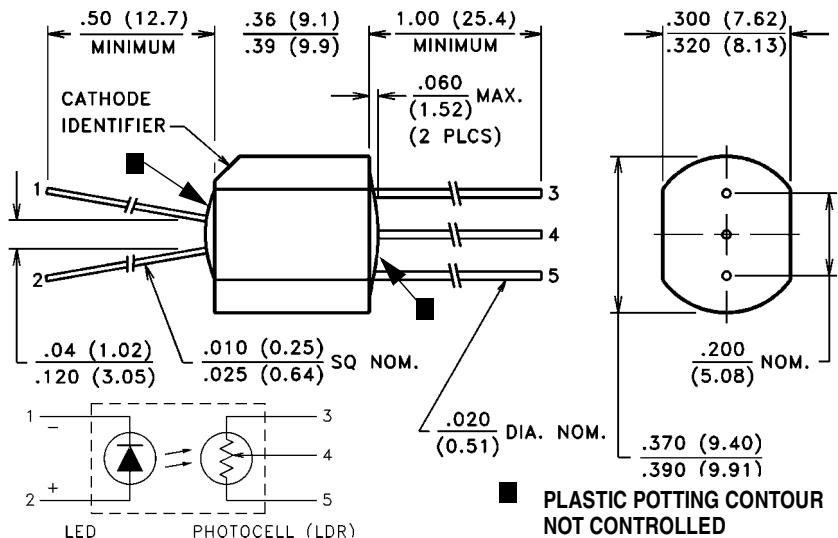

DESCRIPTION

VTL5C2/2 features a very steep slope, low temperature coefficient of resistance, and a small light history memory.

VTL5C3/2 has a steep slope, good dynamic range, a very low temperature coefficient of resistance, and a small light history memory.

ABSOLUTE MAXIMUM RATINGS @ 25°C

Maximum Temperatures		LED Forward Voltage Drop @ 20 mA:	2.0V (1.65V Typ.)
Storage and Operating:	-40°C to 75°C	Min. Isolation Voltage @ 70% Rel. Humidity:	2500 VRMS
Cell Power:	175 mW	Output Cell Capacitance:	5.0 pF
Derate above 30°C:	3.9 mW/°C	Cell Voltage:	50V (VTL5C2/2), 100V (VTL5C2/3)
LED Current:	40 mA 1	Input - Output Coupling Capacitance:	0.5 pF
Derate above 30°C:	0.9 mA/°C		
LED Reverse Breakdown Voltage:	3.0 V		

ELECTRO-OPTICAL CHARACTERISTICS @ 25°C

Part Number	Material Type	ON Resistance 2		OFF 3 Resistance @ 10 sec. (Min.)	Slope (Typ.) @ 0.5 mA / R @ 5 mA	Dynamic Range (Typ.) $\frac{R_{DARK}}{R @ 20 mA}$	Response Time 4	
		Input current	Dark Adapted (Typ.)				Turn-on to 63% Final R_{ON} (Typ.)	Turn-off (Decay) to 100 k Ω (Max.)
VTL5C2/2	Ø	5 mA 40 mA	2.5 k Ω 700 Ω	1.0 M Ω	20	65 db	7.0 ms	150 ms
VTL5C3/2	3	1 mA 40 mA	55 k Ω 2 Ω	10 M Ω	19	71 db	3.0 ms	50 ms

Refer to Specification Notes, page 41.

Typical Performance Curves

Output Resistance vs. Input Current
VTL5C2/2

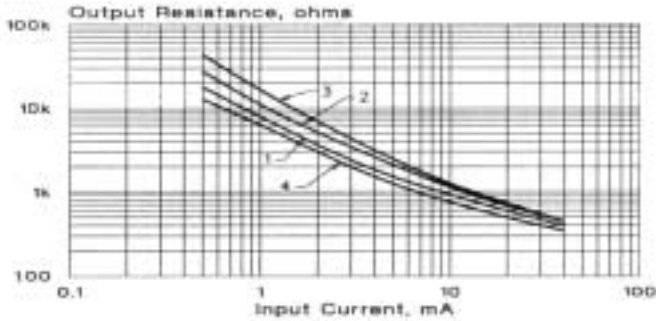

Response Time
VTL5C2/2

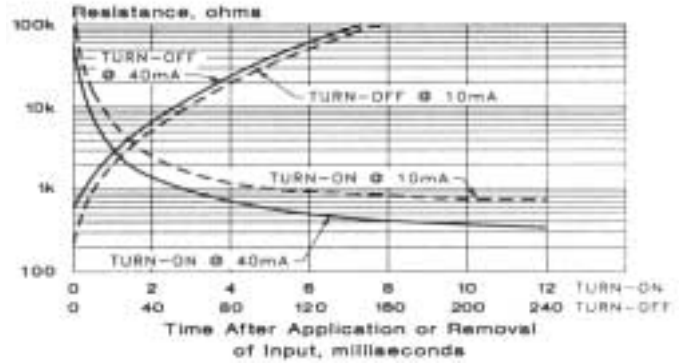

Output Resistance vs. Input Current
VTL5C3/2

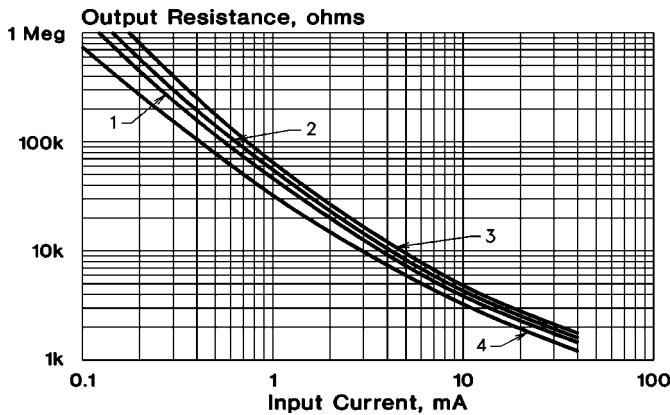

Response Time
VTL5C3/2

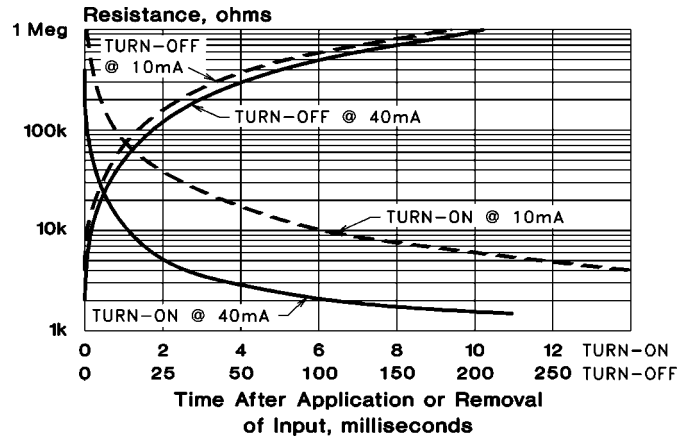

Input Characteristics

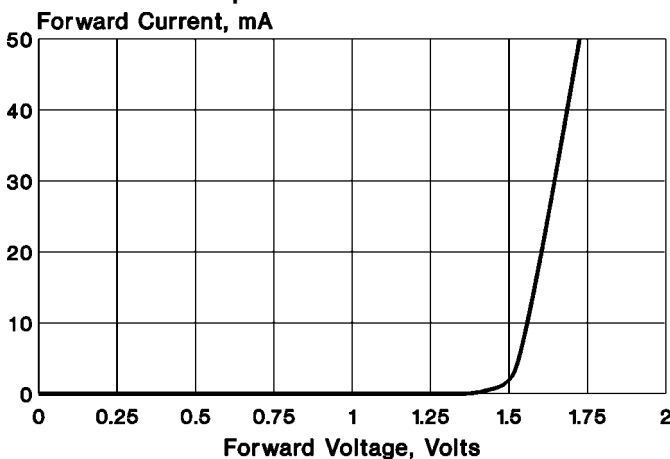

Notes:

1. At 1.0 mA and below, units may have substantially higher resistance than shown in the typical curves. Consult factory if closely controlled characteristics are required at low input currents.
2. Output resistance vs input current transfer curves are given for the following light adapt conditions:
 - (1) 25°C — 24 hours @ no input
 - (2) 25°C — 24 hours @ 40 mA input
 - (3) +50°C — 24 hours @ 40 mA input
 - (4) -20°C — 24 hours @ 40 mA input
3. Response time characteristics are based upon test following adapt condition (2) above.

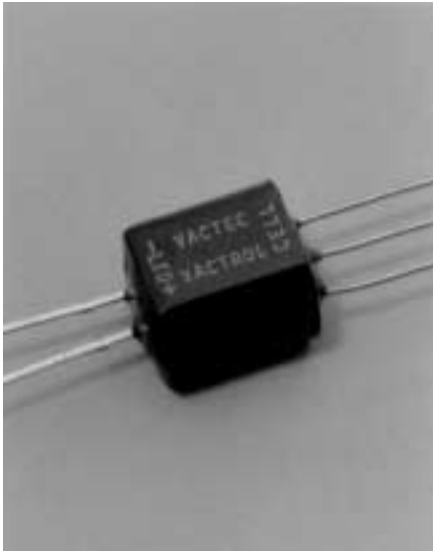

PACKAGE DIMENSIONS INCH (MM)

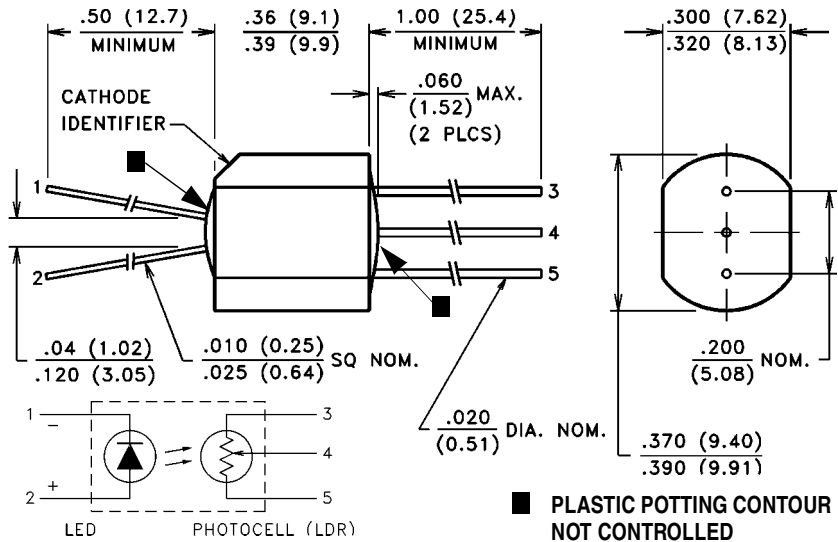

DESCRIPTION

VTL5C4/2 features a very low “on” resistance, fast response time, with a smaller temperature coefficient of resistance than VTL5C1.

ABSOLUTE MAXIMUM RATINGS @ 25°C

Maximum Temperatures		LED Forward Voltage Drop @ 20 mA:	2.0V (1.65V Typ.)
Storage and Operating:	-40°C to 75°C	Min. Isolation Voltage @ 70% Rel. Humidity:	2500 VRMS
Cell Power:	175 mW	Output Cell Capacitance:	5.0 pF
Derate above 30°C:	3.9 mW/°C	Cell Voltage:	30V
LED Current:	40 mA 1	Input - Output Coupling Capacitance:	0.5 pF
Derate above 30°C:	0.9 mA/°C		
LED Reverse Breakdown Voltage:	3.0 V		

ELECTRO-OPTICAL CHARACTERISTICS @ 25°C

Part Number	Material Type	ON Resistance 2		OFF 3 Resistance @ 10 sec. (Min.)	Slope (Typ.) @ 0.5 mA / R @ 5 mA	Dynamic Range (Typ.) $\frac{R_{DARK}}{R @ 20 mA}$	Response Time 4	
		Input current	Dark Adapted (Typ.)				Turn-on to 63% Final R_{ON} (Typ.)	Turn-off (Decay) to 100 k Ω (Max.)
VTL5C4/2	4	1 mA 10 mA	1.5 k Ω 150 Ω	400 Ω	8.3	68 db	6.0 ms	1.5 sec

Refer to Specification Notes, page 41.

Typical Performance Curves (Per Element)

Output Resistance vs. Input Current
VTL5C4/2

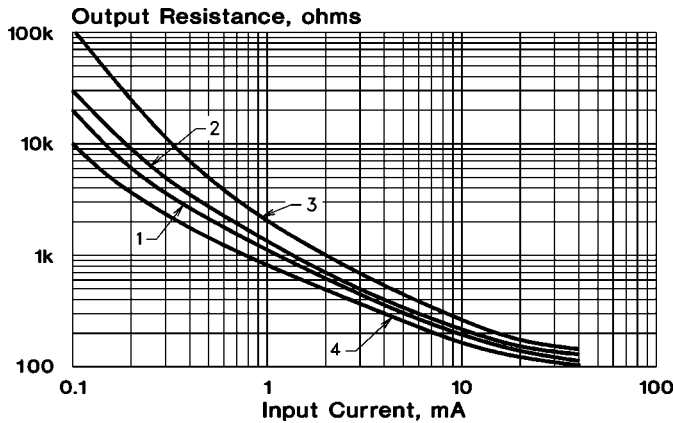

Response Time
VTL5C4/2

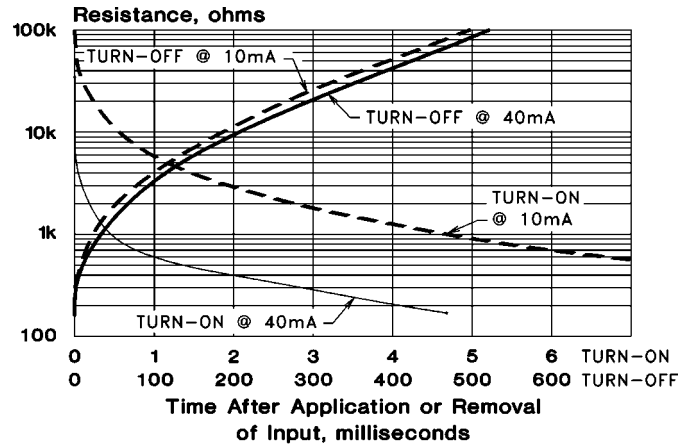

Input Characteristics

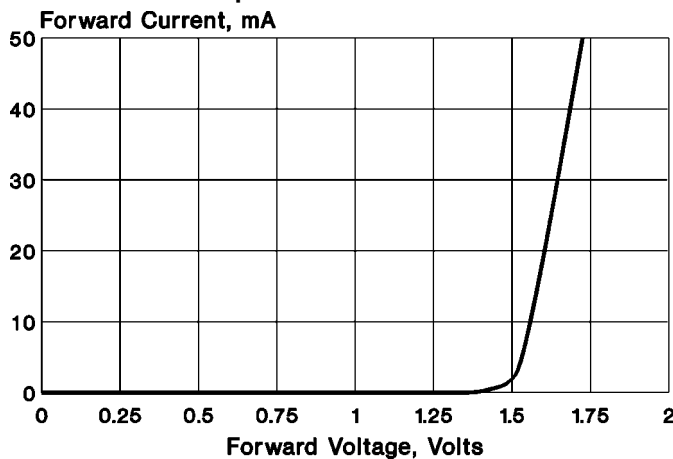

Notes:

- At 1.0 mA and below, units may have substantially higher resistance than shown in the typical curves. Consult factory if closely controlled characteristics are required at low input currents.
- Output resistance vs input current transfer curves are given for the following light adapt conditions:
 - 25°C — 24 hours @ no input
 - 25°C — 24 hours @ 40 mA input
 - +50°C — 24 hours @ 40 mA input
 - 20°C — 24 hours @ 40 mA input
- Response time characteristics are based upon test following adapt condition (2) above.

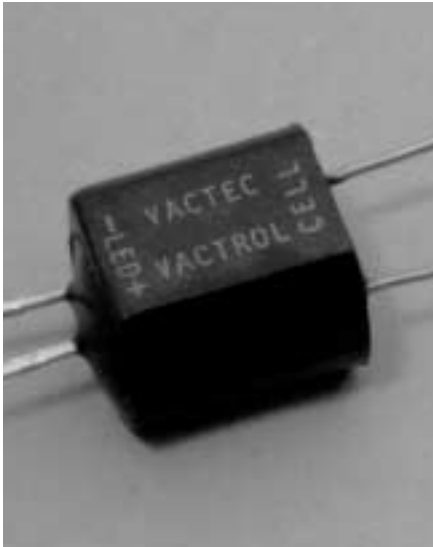

PACKAGE DIMENSIONS INCH (MM)

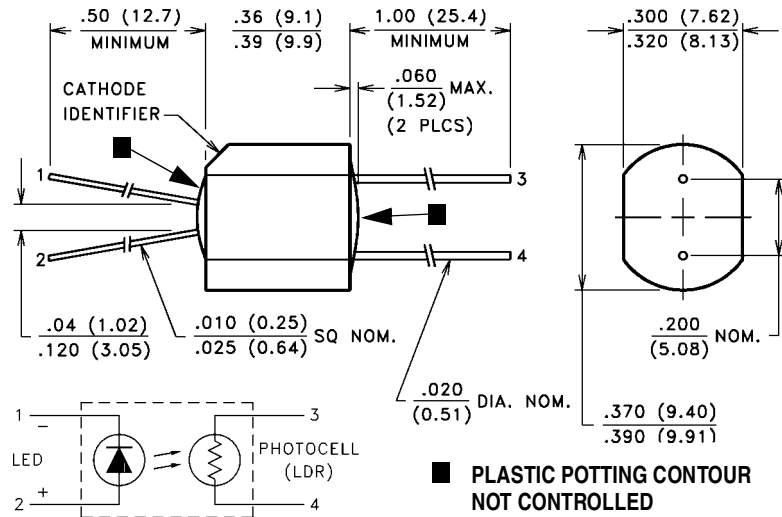

DESCRIPTION

VTL5C6 has a large dynamic range, high dark resistance, a low temperature coefficient of resistance, and a small light history memory. VTL5C7 is a shallow sloped device with good dynamic range, average temperature coefficient of resistance, speed of response, and light history memory.

ABSOLUTE MAXIMUM RATINGS @ 25°C

Maximum Temperatures		LED Forward Voltage Drop @ 20 mA:	2.0V (1.65V Typ.)
Storage and Operating:	-40°C to 75°C	Min. Isolation Voltage @ 70% Rel. Humidity:	2500 VRMS
Cell Power:	175 mW	Output Cell Capacitance:	5.0 pF
Derate above 30°C:	3.9 mW/°C	Cell Voltage:	250V (VTL5C6), 50V (VTL5C7)
LED Current:	40 mA 1	Input - Output Coupling Capacitance:	0.5 pF
Derate above 30°C:	0.9 mA/°C		
LED Reverse Breakdown Voltage:	3.0 V		

ELECTRO-OPTICAL CHARACTERISTICS @ 25°C

Part Number	Material Type	ON Resistance 2		OFF 3 Resistance @ 10 sec. (Min.)	Slope (Typ.) @ 0.5 mA / R @ 5 mA	Dynamic Range (Typ.) R _{DARK} / R @ 20 mA	Response Time 4		
		Input current	Dark Adapted (Typ.)				Turn-on to 63% Final R _{ON} (Typ.)	Turn-off (Decay) to (Max.)	
							1 MΩ	100 kΩ	
VTL5C6	0	1 mA 10 mA 40 mA	75 kΩ 10 kΩ 2 kΩ	100 MΩ	16.7	88 db	3.5 ms	50 ms	
VTL5C7	7	0.4 mA 2 mA	5 kΩ 1.1 kΩ	1 MΩ	5.7	75 db	6.0 ms		1 sec

Refer to Specification Notes, page 41.

Typical Performance Curves

Output Resistance vs. Input Current
VTL5C6

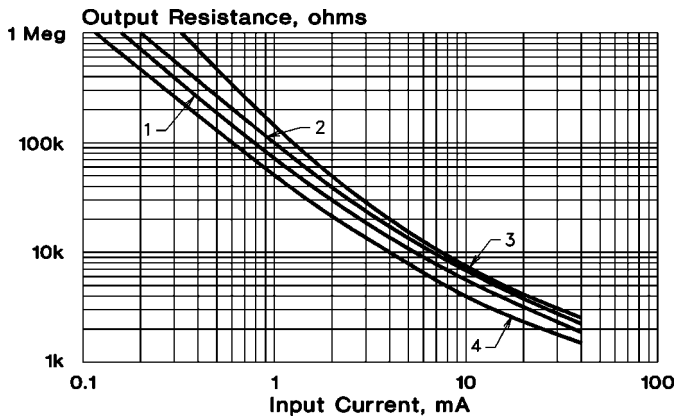

Response Time
VTL5C6

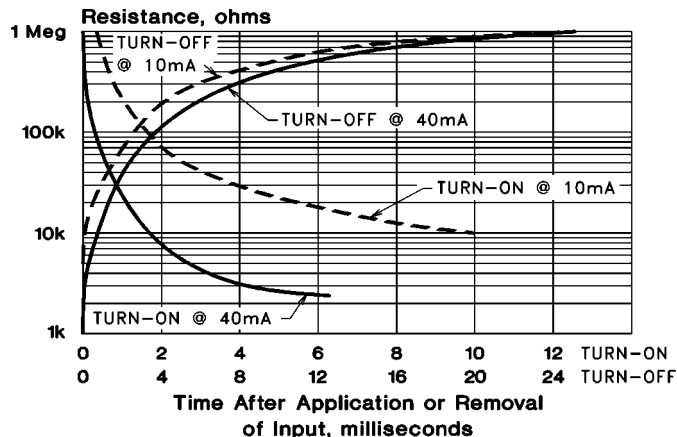

Output Resistance vs. Input Current
VTL5C7

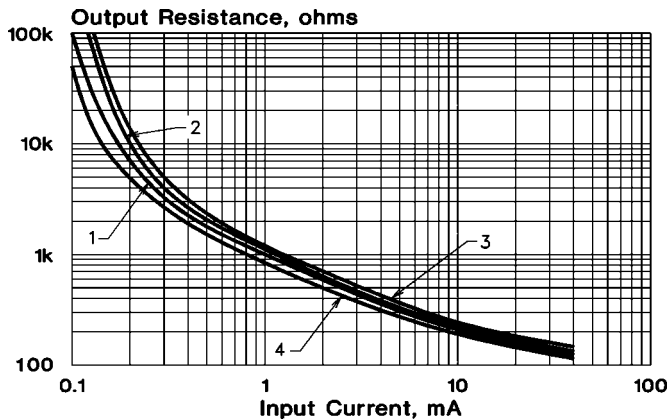

Response Time
VTL5C7

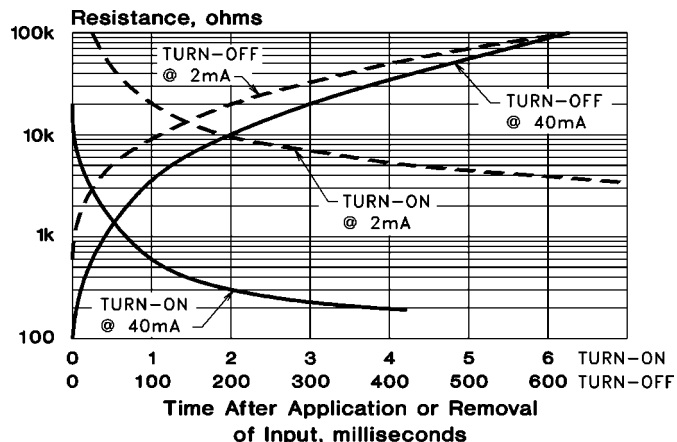

Input Characteristics

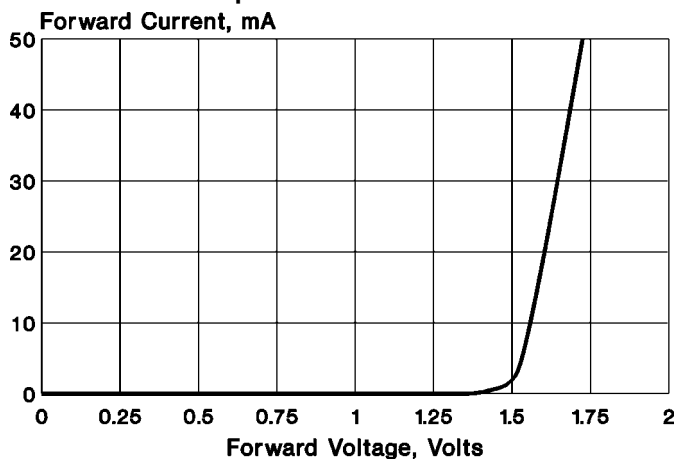

Notes:

- At 1.0 mA and below, units may have substantially higher resistance than shown in the typical curves. Consult factory if closely controlled characteristics are required at low input currents.
- Output resistance vs input current transfer curves are given for the following light adapt conditions:
 - 25°C — 24 hours @ no input
 - 25°C — 24 hours @ 40 mA input
 - +50°C — 24 hours @ 40 mA input
 - 20°C — 24 hours @ 40 mA input
- Response time characteristics are based upon test following adapt condition (2) above.

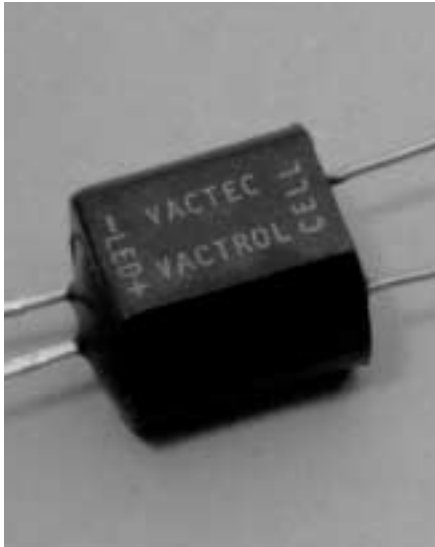

PACKAGE DIMENSIONS INCH (MM)

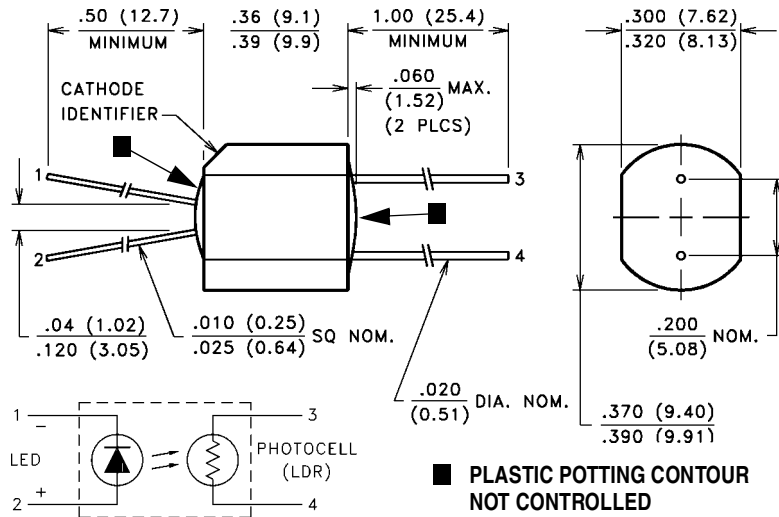

DESCRIPTION

VTL5C8 is similar to VTL5C2 with a low temperature coefficient of resistance and little light history memory, but has a more shallow slope and a lower "on" resistance at low (1 mA) drive currents.

ABSOLUTE MAXIMUM RATINGS @ 25°C

Maximum Temperatures		LED Forward Voltage Drop @ 20 mA:	2.8V (2.2V Typ.)
Storage and Operating:	-40°C to 75°C	Min. Isolation Voltage @ 70% Rel. Humidity:	2500 VRMS
Cell Power:	175 mW	Output Cell Capacitance:	5.0 pF
Derate above 30°C:	3.9 mW/°C	Cell Voltage:	500V
LED Current:	40 mA 1	Input - Output Coupling Capacitance:	0.5 pF
Derate above 30°C:	0.9 mA/°C		
LED Reverse Breakdown Voltage:	3.0 V		

ELECTRO-OPTICAL CHARACTERISTICS @ 25°C

Part Number	Material Type	ON Resistance 2		OFF Resistance 3 @ 10 sec. (Min.)	Slope (Typ.) @ 0.5 mA R @ 5 mA	Dynamic Range (Typ.) R _{DARK} R @ 20 mA	Response Time 4	
		Input current	Dark Adapted (Typ.)				Turn-on to 63% Final R _{ON} (Typ.)	Turn-off (Decay) to 100 kΩ (Max.)
VTL5C8	0	1 mA 4 mA 16 mA	4.8 kΩ 1.8 kΩ 1.0 kΩ	10 MΩ	8	80 db	4 ms	60 ms

Refer to Specification Notes, page 41.

Typical Performance Curves

Output Resistance vs. Input Current
VTL5C8

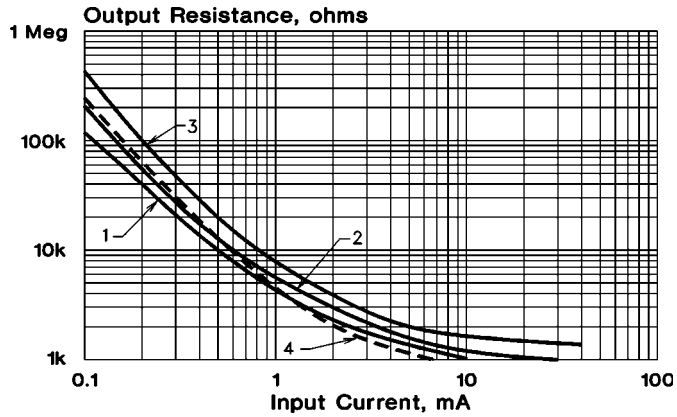

Response Time
VTL5C8

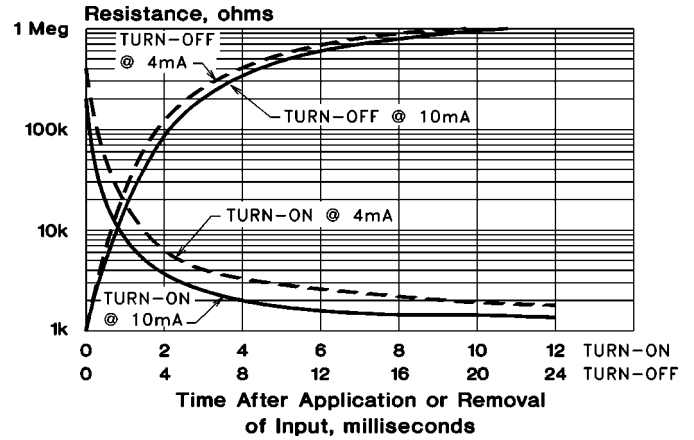

Input Characteristics

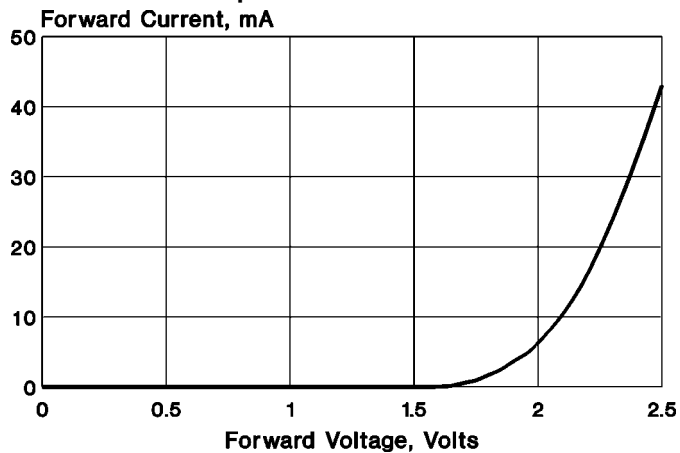

Notes:

- At 1.0 mA and below, units may have substantially higher resistance than shown in the typical curves. Consult factory if closely controlled characteristics are required at low input currents.
- Output resistance vs input current transfer curves are given for the following light adapt conditions:
 - 25°C — 24 hours @ no input
 - 25°C — 24 hours @ 40 mA input
 - +50°C — 24 hours @ 40 mA input
 - 20°C — 24 hours @ 40 mA input
- Response time characteristics are based upon test following adapt condition (2) above.

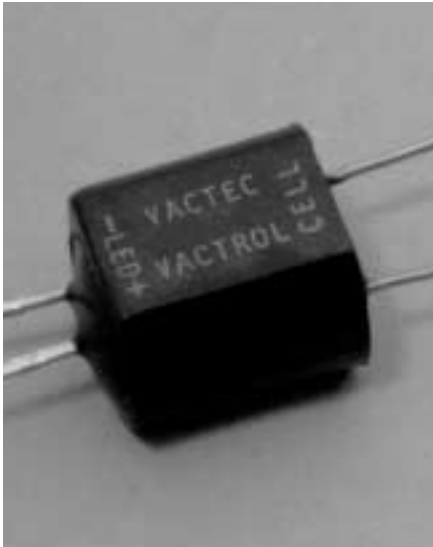

PACKAGE DIMENSIONS INCH (MM)

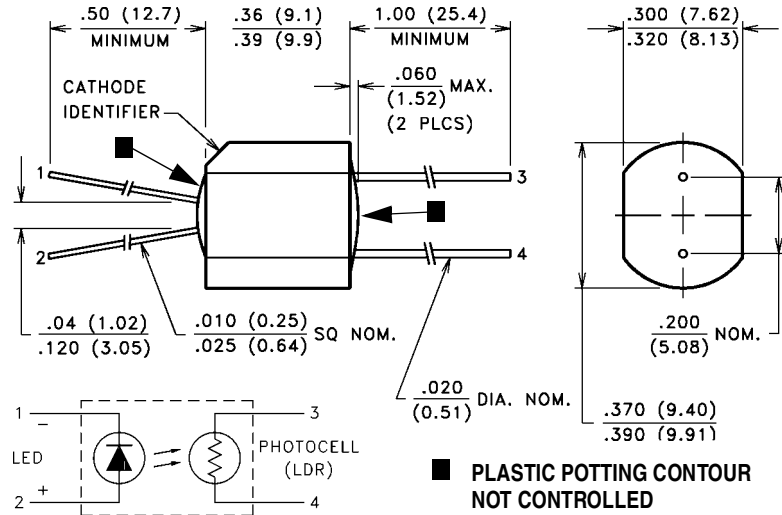

DESCRIPTION

VTL5C9 has a 112 db dynamic range, fast response time, high dark resistance, but with a more shallow slope and lower “on” resistance at low (1 mA) drive currents than the VTL5C1. VTL510 offers a low “on” resistance at low drive currents, a fast response time, and has a smaller temperature coefficient than the VTL5C9.

ABSOLUTE MAXIMUM RATINGS @ 25°C

Maximum Temperatures		LED Forward Voltage Drop @ 20 mA:	2.8V (2.2V Typ.)
Storage and Operating:	-40°C to 75°C	Min. Isolation Voltage @ 70% Rel. Humidity:	2500 VRMS
Cell Power:	175 mW	Output Cell Capacitance:	5.0 pF
Derate above 30°C:	3.9 mW/°C	Cell Voltage:	100V (VTL5C9), 50V (VTL5C10)
LED Current:	40 mA 1	Input - Output Coupling Capacitance:	0.5 pF
Derate above 30°C:	0.9 mA/°C		
LED Reverse Breakdown Voltage:	3.0 V		

ELECTRO-OPTICAL CHARACTERISTICS @ 25°C

Part Number	Material Type	ON Resistance 2		OFF 3 Resistance @ 10 sec. (Min.)	Slope (Typ.) @ 0.5 mA / R @ 5 mA	Dynamic Range (Typ.) $\frac{R_{DARK}}{R @ 20 mA}$	Response Time 4	
		Input current	Dark Adapted (Typ.)				Turn-on to 63% Final R_{ON} (Typ.)	Turn-off (Decay) to 100 k Ω (Max.)
VTL5C9	1	2 mA	630 Ω	50 M Ω	7.3	112 db	4.0 ms	50 ms
VTL5C10	4	2 mA	400 Ω	400 K Ω	3.8	75 db	1.0 ms	1.5 sec

Refer to Specification Notes, page 41.

Typical Performance Curves

Output Resistance vs. Input Current
VTL5C9

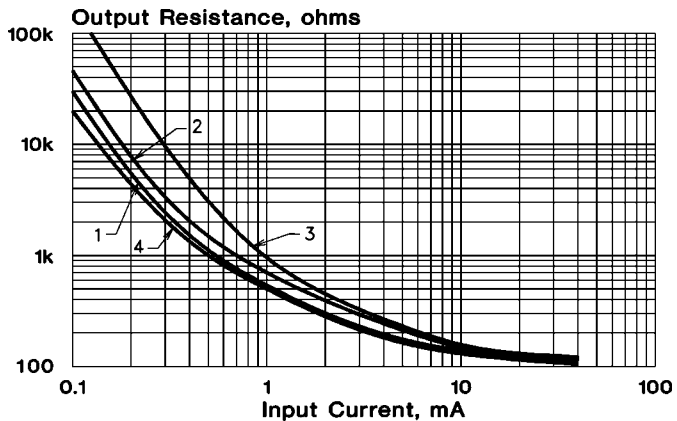

Response Time
VTL5C9

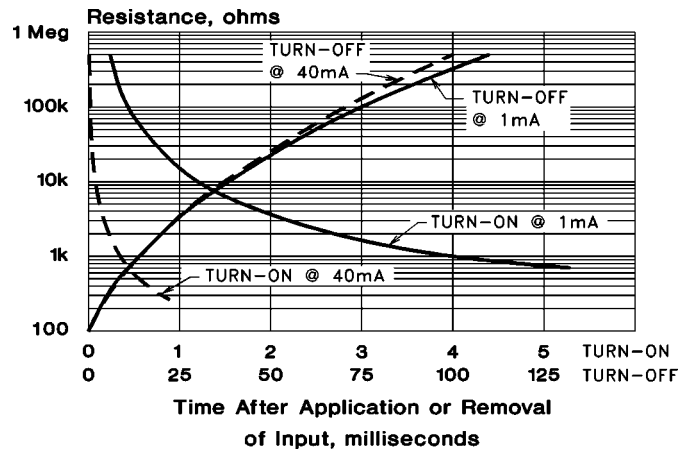

Output Resistance vs. Input Current
VTL5C10

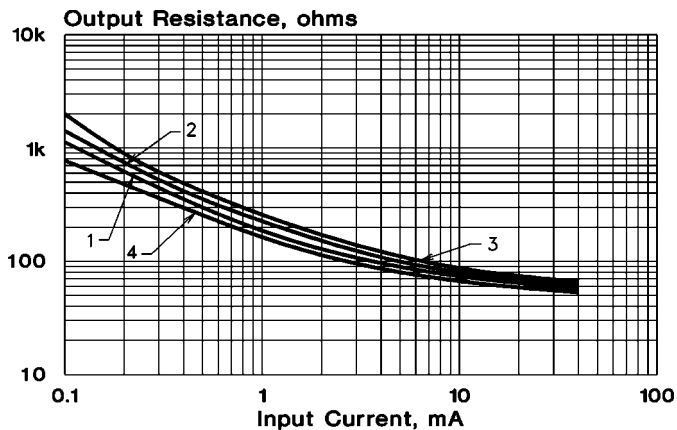

Response Time
VTL5C10

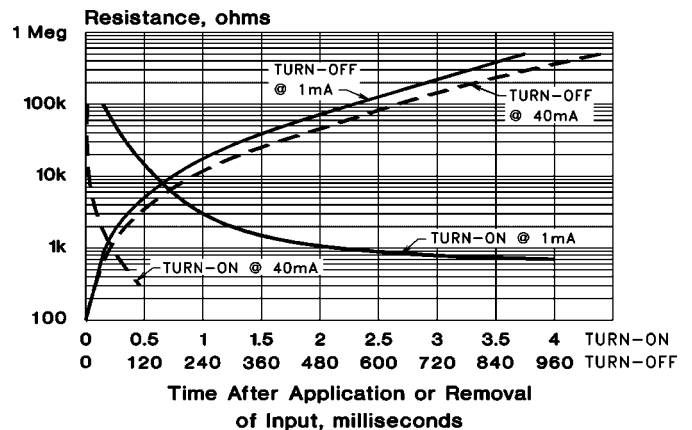

Input Characteristics

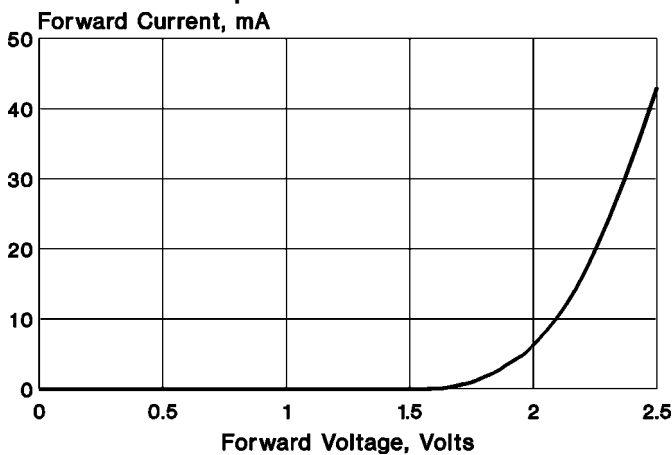

Notes:

- At 1.0 mA and below, units may have substantially higher resistance than shown in the typical curves. Consult factory if closely controlled characteristics are required at low input currents.
- Output resistance vs input current transfer curves are given for the following light adapt conditions:
 - 25°C — 24 hours @ no input
 - 25°C — 24 hours @ 40 mA input
 - +50°C — 24 hours @ 40 mA input
 - 20°C — 24 hours @ 40 mA input
- Response time characteristics are based upon test following adapt condition (2) above.

Application Notes—Analog Optical Isolators

APPLICATION NOTE #1 Audio Applications

The LDR output element of AOIs is almost purely resistive in nature. This property makes the AOI a very useful device for the control of AC signals. Further, because AOIs also possess very low noise and low harmonic distortion characteristics, they are ideal for use as variable resistors, capable of being remotely adjusted in a wide range of audio applications and control circuits.

The focus of this note is on the use of AOIs in audio applications. However, many of the approaches used are equally applicable to higher frequency AC amplification and control circuits.

Control Circuits

Voltage Divider Circuits

The output element of the AOI is a two terminal variable resistor and may be used in a voltage divider circuit as shown in Figures 1a and 1b.

Shunt Input Control

Figure 1a shows the AOI as the shunt element. With $I_F = 0$, the photocell has a very high resistance so $e_{out} = e_{in}$. When I_F is injected into the LED, the AOI output resistance decreases pulling down the output voltage. Since the cell cannot be driven to zero resistance, the value of R_1 must be selected to give the desired maximum attenuation.

A VTL5C4 with a maximum “on” resistance of 200 ohms at $I_F = 10$ mA requires an R_1 of 6100 ohms for 30 db voltage attenuation (producing a 1000:1 power ratio). The actual attenuation ratio will be greater since the 10 mA “on” resistance is typically 125 ohms.

When the maximum I_F is less than 10 mA, the series resistance must be greater to get the same attenuation ratio. If R_1 is made large, the insertion loss (db attenuation at $I_F = 0$) will be higher when the output is loaded. The maximum voltage across the photocell in this circuit is equal to the input voltage assuming no insertion loss. An input voltage as high as 5 – 10V will produce noticeable distortion but that will drop as I_F is increased. To minimize distortion, the voltage across the cell should be kept below 1.0V at the normal operating point.

Series Input Control

With an AOI as the series element as shown in Figure 1b, $e_{out} = 0$ at $I_F = 0$. The maximum voltage across the cell is e_{in} , but decreases as I_F increases.

Op-Amp Feedback Resistor Control

The AOI may also be used as the input or feedback resistor of an operational amplifier. When used in the feedback loop, Figure 1c, a fixed resistor should be used in parallel. With no parallel limiting

resistor, the feedback may approach an open circuit condition at maximum gain. In this open loop state, the circuit becomes unstable and may latch up. The parallel resistor R_3 sets the maximum gain of the amplifier and stabilizes the DC output voltage. Resistor R_2 is in series with the AOI output and sets the minimum gain of the circuit. For op-amps with unity gain compensation, R_2 is set equal to R_3 so the circuit gain does not drop below one. The maximum voltage on the cell (LDR) is e_{out} . If minimizing distortion is a consideration, e_{out} should be kept below 1.0V.

Op-Amp Input Resistor Control

When the AOI is used as the input resistor of an op-amp, Figure 1d, a fixed resistor in series will limit the maximum gain as well as prevent overload of the previous stage.

Non-Inverting Op-Amp Circuits

The AOI can also be used in non-inverting op-amp circuits. Gain is controlled potentiometrically and, again, resistors should be used to limit the maximum gain. The circuit of Figure 1e requires a resistor in series with the AOI, while the circuit of Figure 1f requires one in parallel.

General Considerations

The circuit application and AOI characteristics will influence the choice of circuit to use. In Figure 1a to 1f, gain vs. I_F curves are given for each circuit, as well as input impedance and gain formulas. Once the proper circuit function is selected, AOI response speed must be considered. Because an LDR (photocell) turns “on” fast and “off” slowly, circuits of Figure 1d and 1e will increase in gain rapidly but be slower in the decreasing gain. The circuits of Figure 1c and 1f respond faster when the gain is reduced. All other design considerations are the same as they would be for any op-amp circuit. In all the amplifier configurations, a gain ratio of 1000:1 or higher can be achieved.

Application Notes—Analog Optical Isolators

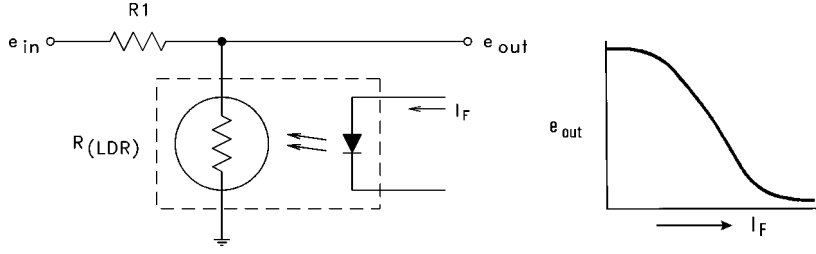
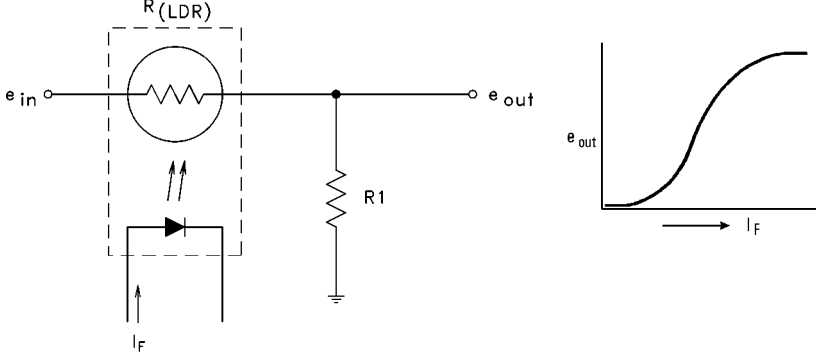
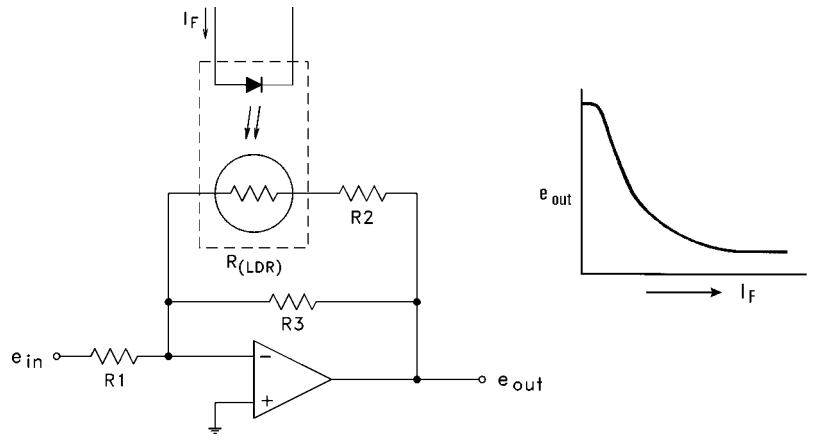
Basic Circuit Configuration	Input Resistance	Gain $\frac{e_{out}}{e_{in}}$
 <p style="text-align: center;">Figure 1a. Shunt Input Control</p>	Variable	$\frac{R_{(LDR)}}{R_1 + R_{(LDR)}}$
 <p style="text-align: center;">Figure 1b. Series Input Control</p>	Variable	$\frac{R_1}{R_1 + R_{(LDR)}}$
 <p style="text-align: center;">Figure 1c. Feedback Resistor Control</p>	Fixed, Low	$\frac{R_3[R_{LDR} + R_2]}{1[R_{LDR} + R_2 + R_3]}$

Application Notes—Analog Optical Isolators

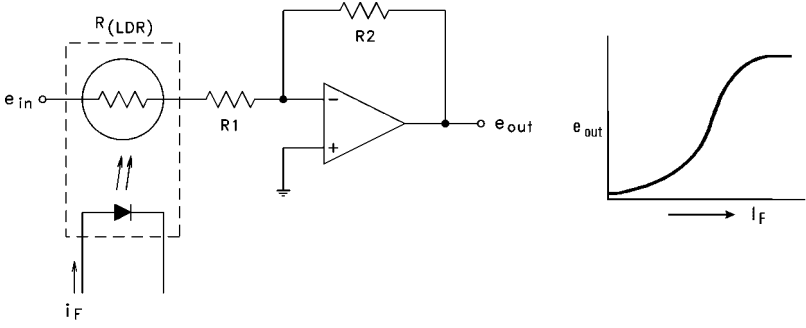
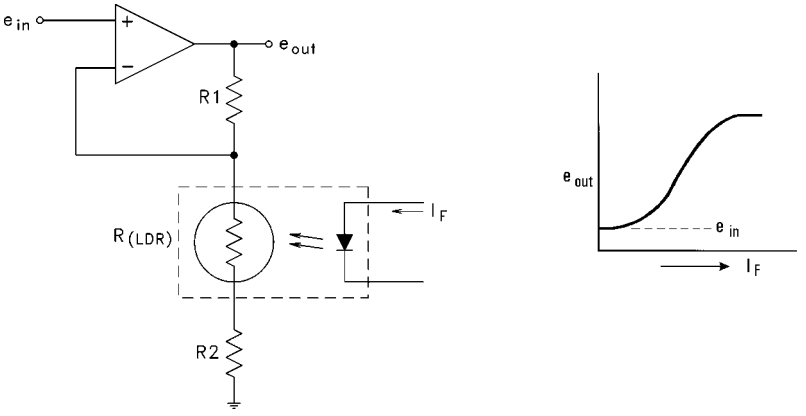
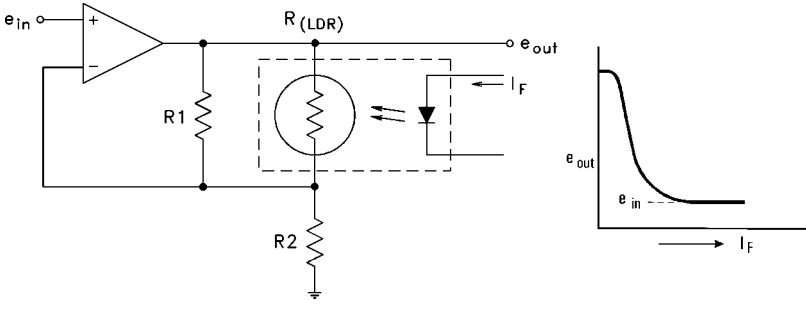
Basic Circuit Configuration	Input Resistance	Gain
 <p style="text-align: center;">Figure 1d. Input Resistor Control</p>	Variable	$\frac{R_2}{R_{(LDR)} + R_1}$
 <p style="text-align: center;">Figure 1e. Potentiometric Gain</p>	Fixed, High	$1 + \frac{R_1}{R_{(LDR)} + R_2}$
 <p style="text-align: center;">Figure 1f. Potentiometric Gain</p>	Fixed, High	$+ \frac{R_1 R_{(LDR)}}{R_2 [R_{(LDR)} + R_1]}$

Application Notes—Analog Optical Isolators

Switching

Mechanical switching of low level audio signals requires the use of switches with precious metal contacts. Sudden changes in signal can cause the speakers to thump and damage may occur if the speaker is underdamped. A simple way to avoid these problems is to use an AOI in place of a mechanical switch. In the circuit of Figure 1d, the initial resistance of the LDR cell is so high that amplifier gain is essentially zero. A step change in forward current through the LED is translated into a slower time change in the cell resistance. The resistance drops to 10 times the final value in one millisecond or less. As the resistance continues to drop, the final value is approached exponentially. Express in terms of conductivity:

$$G = G_0[1 - \exp(-t/tc)] \text{ mhos}$$

and: $R = 1/G \text{ ohms}$

where:

G = conductance, mhos

t = time, ms

tc = time constance of the photocell, ms

If R_1 is made equal to nine times the final value of resistance, the response to 50% signal will occur in 1.0 ms. The time to get to within

0.5 db of full signal is one time constant, which is usually only a few milliseconds. The step change of a switch has been transformed into a rapid but smooth increase in signal level. In addition, the possibility of turn-on in the middle of a peak has been eliminated.

Turn-off is slower and depends on the ratio of R_1 to the final value of photocell resistance. A high ratio will slow down the turn-off and speed up the turn-on.

This circuit can be extended into a matrix as shown in Figure 2. While a 3 x 3 matrix is shown, the number of nodes is not limited. Individual inputs can be summed into a single output or connected to more than one output. A matrix can be made very compact with the output amplifiers mounted very close to reduce pickup. The op-amps eliminate any crosstalk between the inputs since the summing point is at virtual ground.

The controls for the matrix are usually remotely located. The DC current through the LEDs may be controlled by switches, manual potentiometers, or a computer. The matrix may be used for simple ON-OFF gating, summing of several signals, or proportional control. When proportional control is used, the output should be continuously supervised to correct for changes in signal level due to photocell resistance variation from temperature, light adapt history, and self heating.

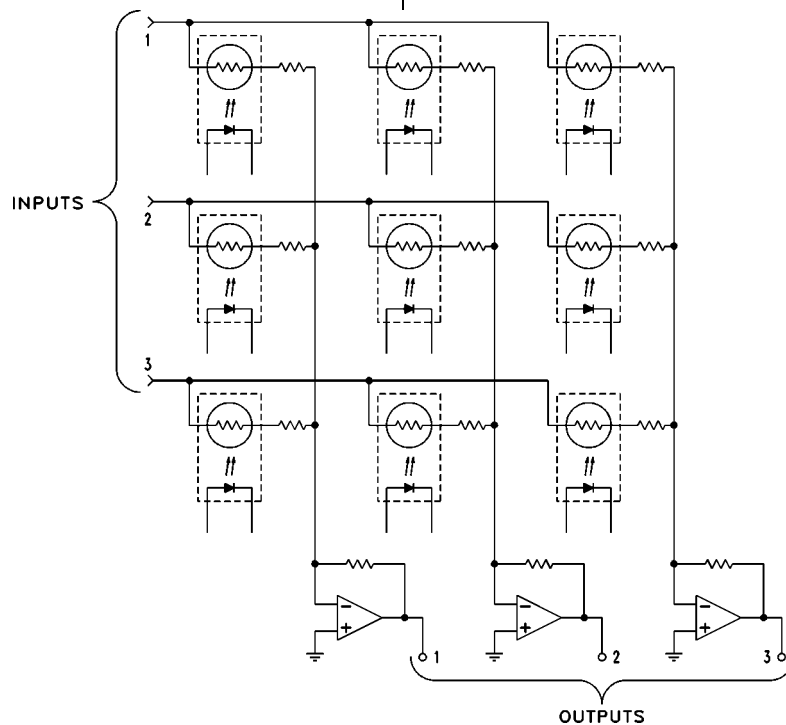

Figure 2. Switching Matrix

Application Notes—Analog Optical Isolators

Gating and Muting

Background noise becomes very objectionable when a signal level in a program is low. Noise is any unwanted sound and may be due to tape hiss or amplifier hum. These noises can be eliminated by selective use of gating and muting, that is, turning the amplifier on when the signal level is high and off when it is low. This technique can also remove or reduce unwanted echo, print through, presence or any other distracting signal during portions of a program which are normally silent. The gating circuit must be completely transparent to the listener, having a smooth, rapid operation with no signal distortion.

A practical gating circuit having these features is shown in Figure 3. The circuit has five basic sections: the threshold adjustment, a high AC gain stage, full-wave rectifier, LED driver and an electrically controlled voltage divider. When the signal is below the threshold level, the voltage divider consisting of the AOI and R_{10} has maximum attenuation. When the signal exceeds the threshold, the voltage divider allows the signal to pass through.

The circuit operation is as follows. The THRESHOLD potentiometer applies a portion of the signal to the high gain AC amplifier consisting of op-amp A_1 , resistors R_2 and R_3 and capacitor C_1 . The amplified signal is full-wave rectified by diodes D_1 and D_2 together with op-amp

A_2 which inverts the negative half of the signal. The rectifier charges C_2 used for RELEASE TIME control and drives the base of transistor Q_1 , the LED driver. The threshold voltage is a sum of the forward drop of the rectifying diodes, the voltage drop across R_6 , V_{BE} or Q_1 and V_F of the LED. This voltage is 2.5 – 3.0V and when referred to the input gives a threshold of 2.5 – 3.0 mV at the amplifier.

The circuit can be set up for a specified threshold voltage. Release time is usually determined empirically. A typical set up procedure uses an audio signal containing spoken dialog. Initially, the THRESHOLD adjustment is set to the maximum and the RELEASE is set to the minimum. The program is turned on and the THRESHOLD is decreased until the audio starts coming through, but sounds chopped up. The chopping occurs because the circuit is too fast on release. The RELEASE is increased until the audio is smoothed out and sounds normal. Setting of the two controls needs to be made carefully. A threshold set too high cuts off the quieter sounds, while a setting which is too low allows more of the noise to come through. Short release time causes more chopping of the audio and can create some distortion at the lower frequencies. Long release time keeps the gate open too long allowing noise to come through after the signal is gone. Adjustments should be made incrementally and worked between the two controls until the best sound is achieved.

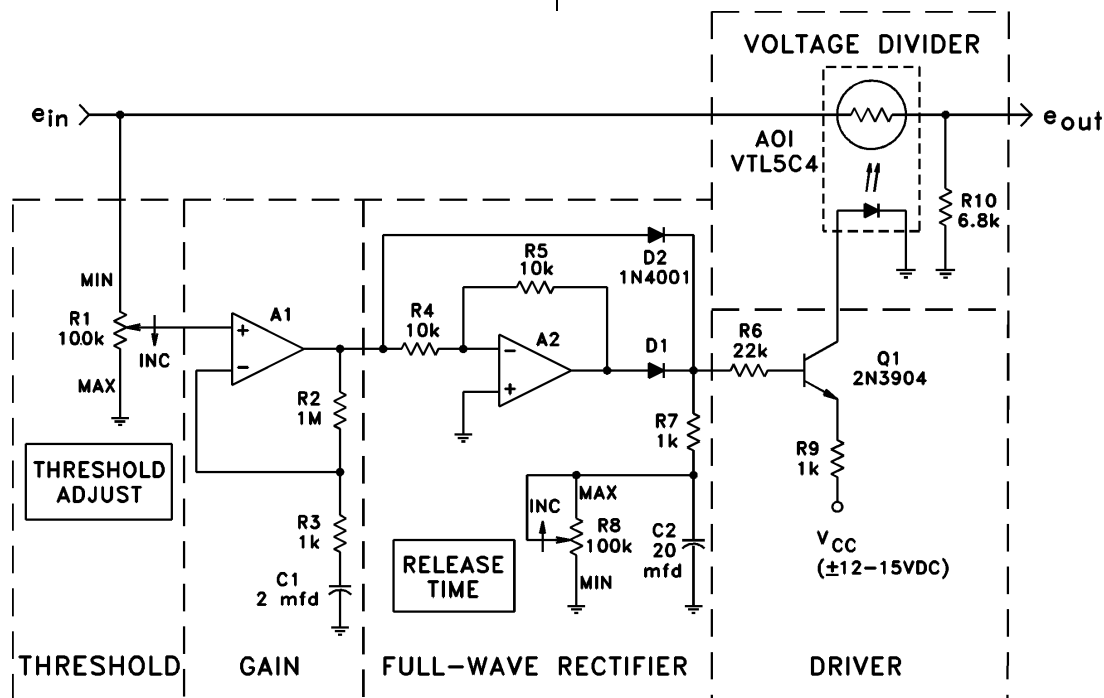

Figure 3. Audio Sound Gate

Application Notes—Analog Optical Isolators

Limiters

If the magnitude of an AC signal varies over a wide range, it may be necessary to amplify or compress the signal before any audio processing can be performed. In other cases, the audio power has to be limited to prevent damage to an output device. Circuits that perform this function on a continual basis need a non-linear element to produce variable gain. However, most non-linear elements introduce distortion. This is unacceptable in a high fidelity audio circuit and other critical applications. Using an AOI, simple circuits can be made to perform this function without introducing distortion or generating any noise.

Signal Limiters

Any circuit that performs as a limiter or compressor must have low gain when the signal magnitude is high and high gain when the signal is low. The gain is adjusted so that a wide dynamic range is compressed into a small one. In other signal processing applications, the signal may need to be virtually constant.

The circuit such as shown in Figure 4a will keep the output level constant when the input voltage varies over a range of 50 – 60 db.

Amplifier A1 operates as an inverting amplifier with a gain:

$$e_{out} / e_{in} = R_{PHOTOCELL} / R_1$$

The feedback resistor is a photocell and has an “off” resistance of 10 megohms, minimum, and an “on” resistance of 5000 ohms with 5.0 mA in the LED. Using the components shown, the gain of this stage varies between 500 with no signal and 0.5 with maximum signal applied. R₂ limits the maximum gain and is needed to prevent the amplifier, A₁

from going open loop when there is no input signal, in which case the cell “off” resistance is much higher than 10 MΩ.

Amplifier A₂ operates as a high input impedance rectifier that drives the LED. The forward drop of the LED is 1.6 – 2.0V, and when the peak output of the rectifier exceeds this value, current will flow into the LED. As the signal increases, more current flows into the LED, driving the photocell resistance lower thus decreasing the amplifier gain. The output of A₁ is regulated at a voltage determined by the forward drop of the LED and the closed loop gain of amplifier A₂. A₂ amplifies the signal by a factor of two, and a 1.8V peak (1.27 VRMS) is required to activate this AOI. This results in the output voltage being held to 0.64 VRMS over a input range of 1 – 600 mV. Changing the value of R₄ changes the gain of the rectifier. Omitting R₄ will double the output voltage because the rectifier gain drops to one. Putting a resistor in series with the LED will cause the regulated voltage to rise as the input is increased (see Figure 4b). As the amplifier gain changes, the amplifier bandwidth also changes. When the signal is low, the amplifier will have the highest gain and lowest bandwidth.

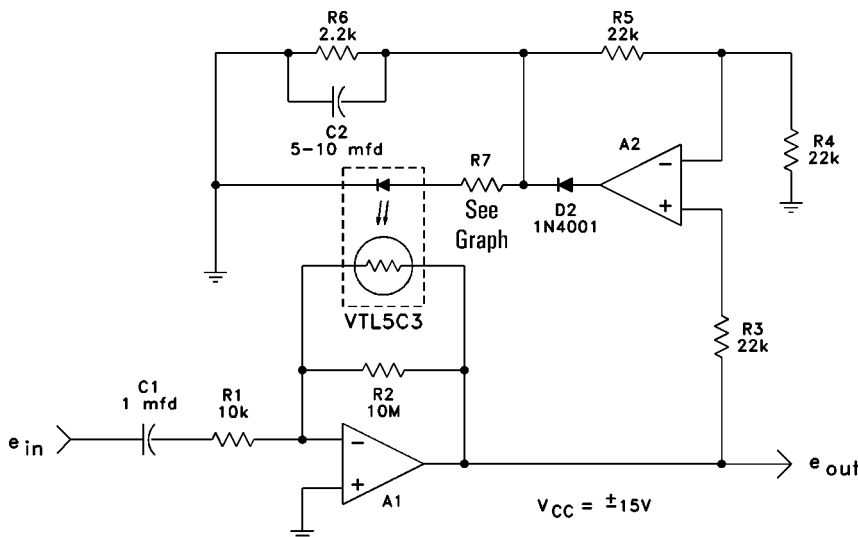

Figure 4a. Peak Sensing Compressor

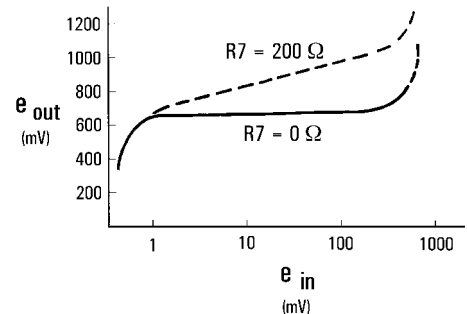

Figure 4b. Output Characteristics

Application Notes—Analog Optical Isolators

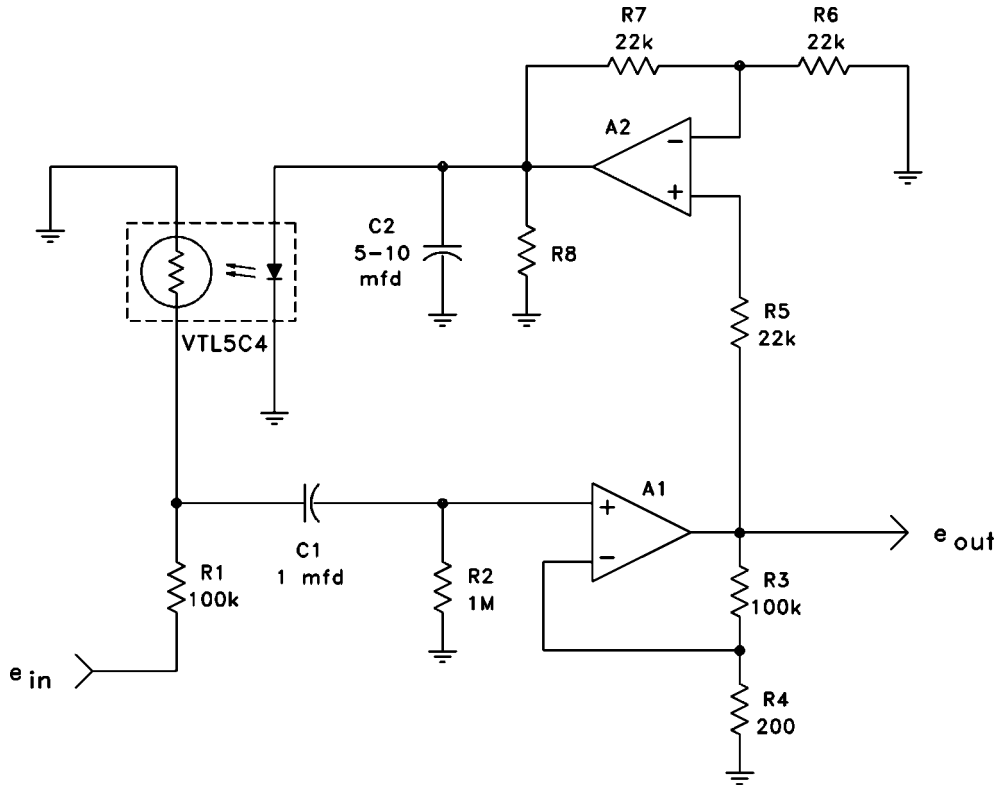

Figure 5. Peak Sensing Compressor with Constant Bandwidth

Variable bandwidth can be avoided if the AOI is used in a voltage divider circuit at the input of a fixed gain amplifier. For the same range of input signals, the amplifier gain must be 500 and the voltage divider must have a range of 1000:1. This configuration is shown in Figure 5. The AOI has been changed to a lower resistance unit to be able to work over the wider range. Also, A₁ is now a high input impedance, non-inverting stage to avoid a high insertion loss. This circuit is useful when the input voltage is high, which allows the use of a lower gain amplifier.

Speaker Power Limiting

Speakers that are driven from high power amplifiers must be protected from excess drive. While ordinary program levels may be well within the rating of the speaker, peaks do occur that can be destructive. The simplest solution is to use a compressor or limiter. Unfortunately, the maximum power that may be applied is not constant over the frequency range. Therefore, the limit must be set to provide protection at the lowest frequency that is expected.

To understand the requirements for effective speaker protection, a brief review of speaker power limitations follows. Figure 7 is a typical maximum sine wave voltage limit for a low frequency speaker commonly called a “woofer”. Above 200 Hz, the maximum allowed voltage or power is constant. The operating temperature at which wire insulation and coil bonding fail establishes this value. Below 200 Hz,

the voltage limit is determined by the allowable diaphragm excursion. For constant voltage on the speaker, the displacement doubles when the frequency is reduced by half. The maximum displacement is determined by the mechanical design of the speaker and exceeding the limit will produce extreme distortion and may even cause mechanical damage.

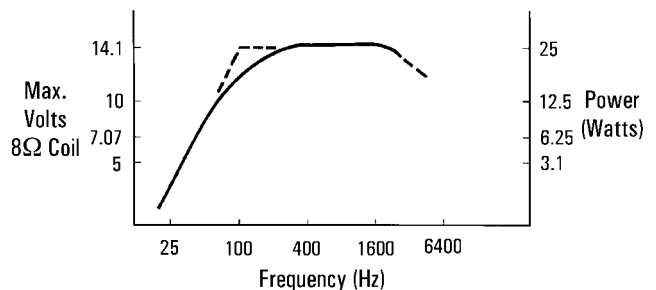

Figure 7. Maximum sine wave Voltage and Power for a Typical Woofer

Application Notes—Analog Optical Isolators

This reduced low frequency power rating can be accommodated by using a limited circuit which reduces the limit threshold when the frequency is below 200 Hz. Figure 8a shows a very simple circuit to do this. At low frequency, the gain of amplifier A_1 is unity. The amplifier has a 6 db/octave gain roll-off starting at 25 Hz and levels off at 100 Hz. Therefore it will take a signal that is four times as large at 100 Hz as at 25 Hz before limiting action starts. Breakpoints in the Frequency vs. Gain curve shown in Figure 8b can be set to match the speaker frequency dependent power limit. Also, potentiometer R_4 can be set to match the power rating and impedance of the speaker.

The threshold is set by the sum of V_{BE} of Q_1 and the forward voltage drops of D_1 and the LED, approximately 2.8V peak or 2.0 VRMS. Once

the threshold has been exceeded, current is injected into the LED of the AOI which attenuates the signal voltage. This voltage divider can be placed anywhere in the signal path. Once the limiter comes into play, the system frequency response will no longer be flat, but no distortion is introduced.

Automatic Gain Control

Automatic gain control (AGC) circuits have electrically programmable references or set points, but in other respects are the same as limiters or compressor circuits. Each has a forward gain amplifier and a loop which controls the gain of that amplifier.

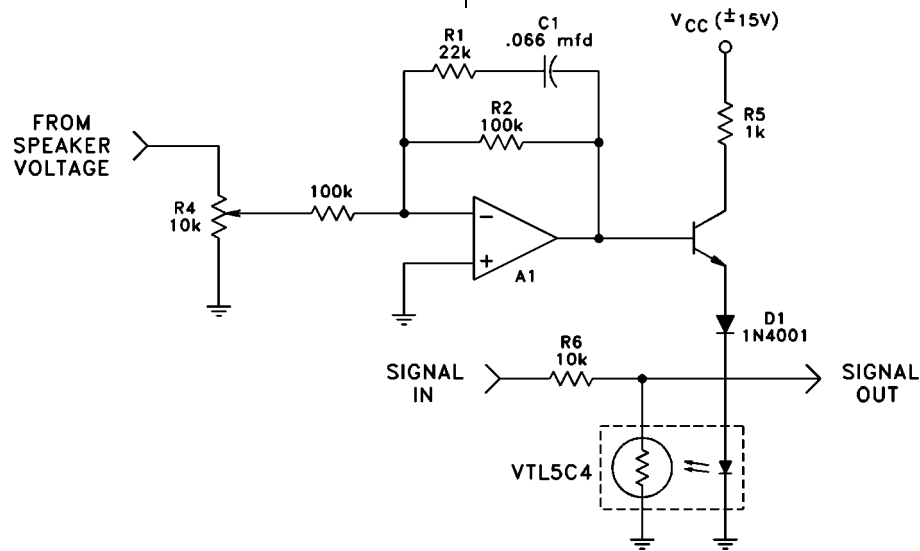

Figure 8a. Speaker Power Limiter with Frequency Compensation

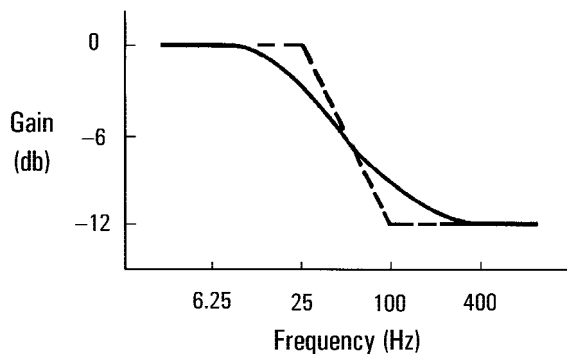

Figure 8b. Amplitude vs. Frequency for the Amplifier

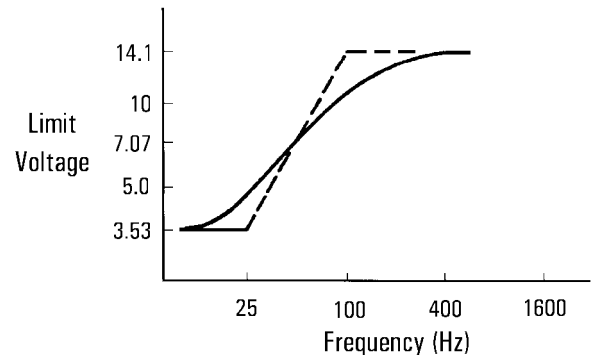

Figure 8c. System Voltage Limits

Application Notes—Analog Optical Isolators

Figure 9 shows an AGC circuit which consists of three main elements: a variable gain amplifier, full-wave active rectifier and a summing amplifier. The variable gain amplifier consists of op-amp A1 with potentiometric gain that is controlled by the resistance of the photocell of the AOI. The gain of this amplifier is:

$$\text{Gain} = 1 + R_2 / R_{\text{PHOTOCELL}}$$

With $R_2 = 100\text{k}$ ohms, the minimum gain is one since the cell “off” resistance is several megohms. The maximum gain is only 100 since the resistance of a typical VTL5C2 is 1000 ohms at an input current of 5.0 mA. If a range of 40 db (100:1) is not adequate, there are several options. R_2 can be increased, the LED drive current for the AOI can be increased or a lower resistance AOI such as the VTL5C4 can be used.

Amplifier A_2 together with diodes D_1 and D_2 and resistors R_3 , R_4 , and R_5 form a full-wave rectifier. The amplifier has a gain of one so the output is equal to the rectified input. There is no offset due to rectifier forward drops so this circuit will rectify signals all the way down to zero volts. Since the DC output of A_2 is not referenced to ground, op-amp A_3 and resistors R_6 , R_7 , R_8 , and R_9 form a fully differential amplifier which shifts the DC reference to ground.

Op-amp A_4 is used as an integrator. The signal from the full-wave rectifier is summed with a reference voltage V_{REF} and integrated. The time constant of the integrator is selected to limit the bandwidth of the control loop as well as assure stability of the loop. If the bandwidth is

too wide, the control loop will follow the signal on an instantaneous basis. The AOI alone is not very fast, but signals with frequencies of 30 – 60 Hz could be distorted if there were no time delay in the integrator.

The AGC circuit operates as follows. When there is no signal, the negative V_{REF} causes A_4 to be at a maximum positive output. Maximum forward current is injected into the LED, driving the cell to a low resistance and the gain of A_1 to the maximum where it stays until there is a signal. A signal at the input terminal is amplified, rectified and algebraically summed with V_{REF} at the inverting terminal of the integrator. The control loop will then act to make the absolute value of the rectified signal equal to the reference voltage. V_{REF} may be a fixed value or a function of some other parameter.

Electrically Controlled Gain

The gain of an amplifier can be electrically programmed using the circuit of Figure 10. An AOI with a center tapped photocell is used, one side in the signal amplifier channel and the other in the control loop. The signal amplifier consists of op-amp A_1 , resistors R_3 and R_2 which set the gain and the input resistor R_5 . The gain of this amplifier is given by:

$$G = \frac{e_{\text{out}}}{e_{\text{in}}} = \frac{(R_2 + R_3)}{R_2}$$

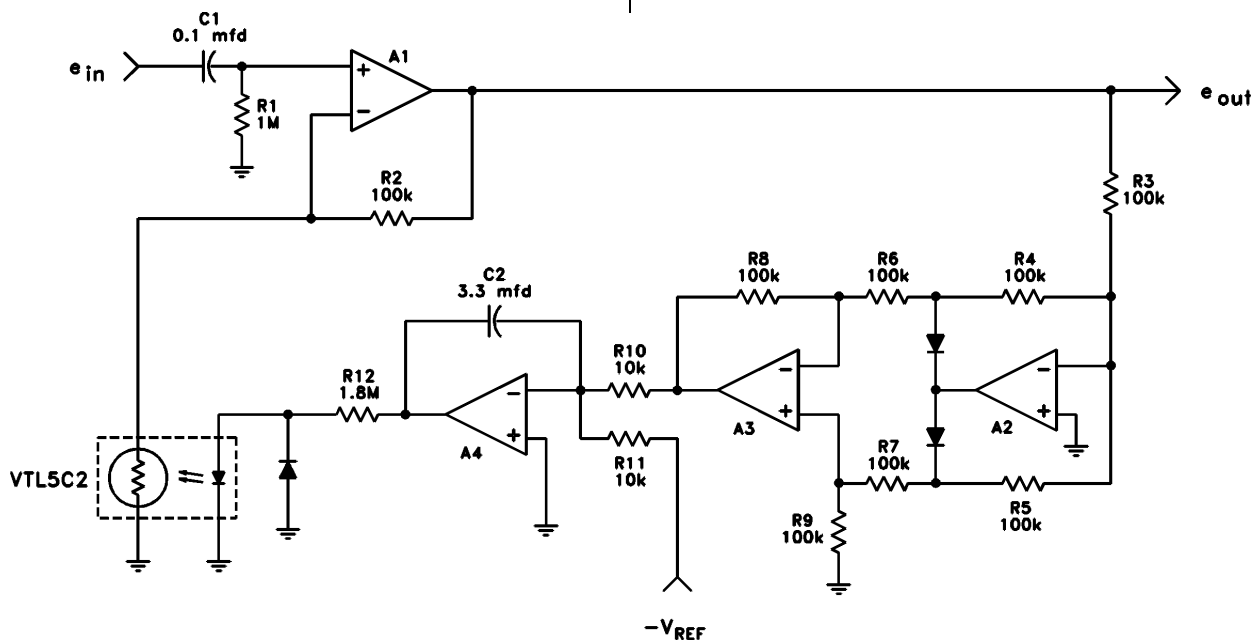

Figure 9. AGC Circuit with Electrical Setpoint

Application Notes—Analog Optical Isolators

The control loop consists of op-amp A₂ and resistors R₁ and R₄. This circuit sets the LED current so that:

$$\frac{V_{REF}}{V_C} = \frac{(R_1 + R_4)}{R_1}$$

If we set:
and:
then:
or:
where

$$\begin{aligned} R_3 &= R_4 \\ R_1 &= R_2 \\ e_{out} / e_{in} &= V_{REF} / V_C \\ e_{out} &= e_{in} (V_{REF} / V_C) \\ V_C &= \text{control voltage} \end{aligned}$$

Note that R₁ and R₂ are the two halves of the cell. These two resistors match within 10% and track over a wide range within 5% so that the gain is closely set by V_C when V_{REF} is fixed.

The limits of operation are:

$$0 < V_C < V_{REF}$$

and the signal must never be so large that amplifier A₁ saturates when the gain is at maximum.

This circuit performs a dividing operation with e_{in} and V_C as the numerator and denominator respectively. The accuracy is limited by the tracking ability of the two sides of the photocell. The error due to matching can be eliminated by trimming R₄.

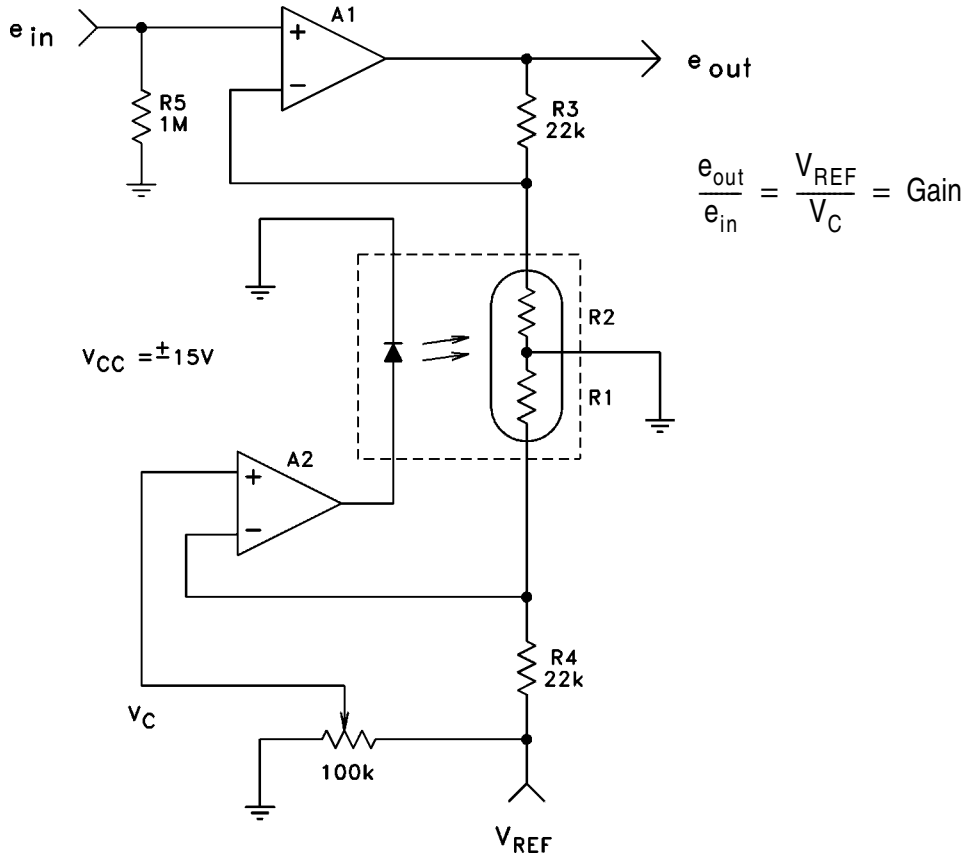

Figure 10. Electrically Programmable Gain

Application Notes—Analog Optical Isolators

APPLICATION NOTE #2

Handling and Soldering AOIs

All opto components must be handled and soldered with care, especially those that use a cast or molded plastic and lead frame construction like the LEDs used in AOIs.

In LED lead frame construction, the emitter chip is mounted directly to one lead and a wire bond is made from the chip to the other lead. The encapsulating plastic is the only support for the lead frame. Care must be taken when forming the leads of plastic opto packages. Excessive mechanical force can cause the leads to move inside the plastic package and damage the wire bonds. Weakened bonds can then “open up” under further mechanical or thermal stressing, producing open circuits.

In order to form leads safely, it is necessary to firmly clamp the leads near the base of the package in order not to transfer any force (particularly tension forces) to the plastic body. This can be accomplished either through use of properly designed tooling or by firmly gripping the leads below the base of the package with a pair of needle nose pliers while the leads are being bent.

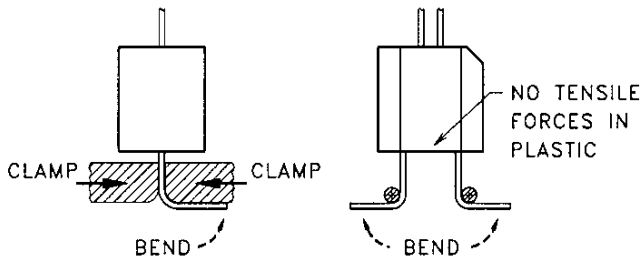

Examples of Tooling Fixtures Used to Form Leads

For highest reliability, avoid flush mounting the AOI body on the printed circuit board. This minimizes mechanical stress set up between the circuit board and the LED and photocell packages. It also reduces solder head damage to the packages.

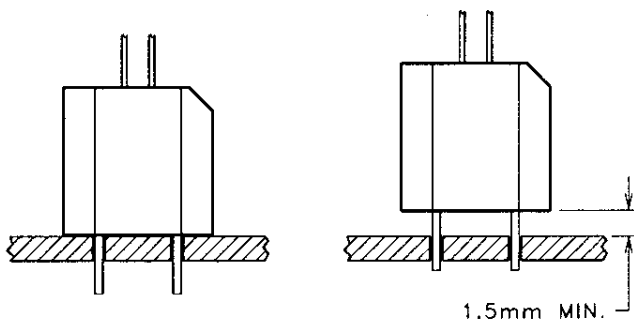

NOT RECOMMENDED RECOMMENDED

Good printed circuit board layout avoids putting any spreading (plastic under tension) force on the leads of the LED and photocell.

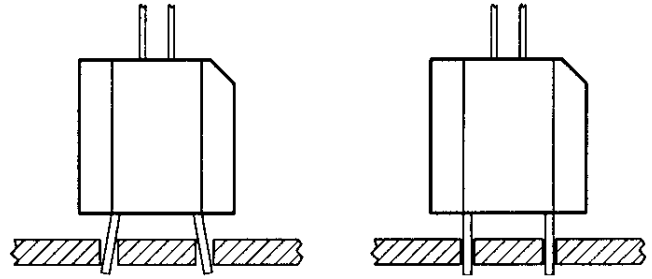

NOT RECOMMENDED RECOMMENDED

When hand soldering, it is important to limit the maximum temperature of the iron by controlling the power. It is best if a 15W or 25W iron is used. The maximum recommended lead soldering temperature (1/16" from the case for 5 seconds) is 260°C. An RMA rosin core solder is recommended.

Sn60 (60% tin / 40% lead) solder is recommended for wave soldering opto components into printed circuit boards. Other alternatives are Sn62 and Sn63. The maximum recommended soldering temperature is 260°C with a maximum duration of 5 seconds.

The amount of tarnish on the leads determines the type of flux to use when soldering devices with silver plated leads.

Condition of Leads	Recommended Flux
Clear Bright Finish (Tarnish Free)	RMA - Mildly Activated
Dull Finish (Minimal Tarnish)	RMA - Mildly Activated
Light Yellow Tint (Mild Tarnish)	RA - Activated
Light Yellow / Tan Color (Moderate Tarnish)	AC - Water Soluble, Organic Acid Flux
Dark Tan / Black Color (Heavy Tarnish)	Leads Need to be Cleaned Prior to Soldering

Cleaners designed for the removal of tarnish from the leads of electronic components are acidic and it is best to keep the immersion time as short as possible (less than 2 seconds) and to immediately wash all devices thoroughly in ten rinses of deionized water.

Application Notes—Analog Optical Isolators

The best policy is one which prevents tarnish from forming. Tarnish, which is a compound formed when silver reacts with sulfur (Ag_2S), can be prevented by keeping the components away from sulfur or sulfur compounds. Since two major sources of sulfur are room air and paper products, it is best to store the devices in protective packaging such as a “silver saver” paper or tightly sealed polyethylene bags.

After soldering, it is necessary to clean the components to remove any rosin and ionic residues. For a listing of recommended cleaning agents please refer to Application Notes #3.

APPLICATION NOTE #3 Recommended Cleaning Agents

The construction of an AOI consists of a cast epoxy LED, ceramic photocell, a molded case and epoxy as the end fill. This construction allows a wide variety of cleaning agents to be used after soldering.

In many cases the devices will be exposed to a post solder cleaning operation which uses one or more solvents to remove the residual solder flux and ionic contaminants. Only certain cleaning solvents are compatible with the plastics used in the AOI packages.

Recommended	Not Recommended
Arklone A	Acetone
Arklone K	Carbon Tetrachloride
Arklone F	Methyl Ethyl Ketone
Blaco-Tron DE-15	Methylene Chloride
Blaco-Tron DI-15	Trichloroethylene (TCE)
Freon TE	Xylene
Freon TES	Trichloroethane FC-111
Freon TE-35	Trichloroethane FC-112
Freon TP	Freon TF
Freon TF-35	Freon TA
Genesolv D	Freon TMC
Genesolv DE-15	Freon TMS
Genesolv DI-15	Genesolv DA
Isopropyl Alcohol	Genesolv DM
Water	Genesolv DMS

This listing of recommended/not recommended solvents represents only a very small percentage of available chemical cleaning agents. Even with this list of recommended solvents it is important to be aware that:

1. Solvent exposure times should be as short as possible.

2. The exact requirement of the cleaning process will vary from customer to customer and application to application.
3. Additives and concentrations will vary from supplier to supplier.

Because of these uncertainties, our recommendation is that all customers carefully evaluate their own cleaning process and draw their own conclusions about the effectiveness and reliability of the process. PerkinElmer cannot assume any responsibility for damage caused by the use of any of the solvents above or any other solvents used in a cleaning process.

PerkinElmer Optoelectronics

Warranty Statement

PerkinElmer Optoelectronics warrants that all items sold will be free from defects in materials and workmanship under normal use and service for a period of one year from the date of shipment. If PerkinElmer Optoelectronics receives notice of such defects during the warranty period, PerkinElmer Optoelectronics shall, at its option, repair or replace any defective components or credit the purchaser's account with the purchase price paid. This warranty shall not apply to items that have been (a) subject to misuse, neglect, accident, damage in transit, abuse or unusual hazard; (b) altered, modified or repaired by anyone other than PerkinElmer Optoelectronics; or (c) used in violation of instructions furnished by PerkinElmer Optoelectronics. The Buyer should contact PerkinElmer Optoelectronics for a return authorization number prior to shipping returned parts.

The specific PerkinElmer Optoelectronics' products shown in this catalog are not authorized or recommended for use as critical components in life support systems or in surgical implant devices wherein a failure or malfunction of the PerkinElmer Optoelectronics product may directly threaten life or cause personal injury. The Buyer agrees to notify PerkinElmer Optoelectronics of any such intended application and to proceed only after receiving the expressed written approval of an officer of PerkinElmer Optoelectronics. Additionally, the user of PerkinElmer Optoelectronics components in life support or implant applications assumes all risks of such use and indemnifies PerkinElmer Optoelectronics against all damages.

In order to provide the best possible products, PerkinElmer Optoelectronics reserves the right to change specifications without prior notice. Information supplied in PerkinElmer Optoelectronics' catalogs, data sheets, and other literature, and information supplied by PerkinElmer Optoelectronics' technical support personnel is believed to be reliable, however, PerkinElmer Optoelectronics cannot assume responsibility for omissions, errors, or misapplication of this information.

It is the responsibility of the Buyer to determine the suitability of PerkinElmer Optoelectronics' products and recommendations in his own specific application, particularly when the products are operated at or near their maximum rating specifications. No license is granted by implication or otherwise of any patent, copyright, or trademark right of PerkinElmer Optoelectronics or others.

PerkinElmer Optoelectronics' warranty, as stated above, shall not be affected or changed by, and no obligation or liability shall grow out of, PerkinElmer Optoelectronics' providing technical advice or service to the Buyer.

PERKINELMER OPTOELECTRONICS MAKES NO OTHER WARRANTIES, EXPRESSED OR IMPLIED, AND EXPRESSLY EXCLUDES AND DISCLAIMS ANY WARRANTIES OF MERCHANTABILITY OR FITNESS FOR A PARTICULAR PURPOSE. THE REMEDIES PROVIDED HEREIN ARE THE BUYER'S SOLE EXCLUSIVE REMEDIES. PERKINELMER OPTOELECTRONICS SHALL NOT BE LIABLE FOR ANY INDIRECT, SPECIAL, INCIDENTAL, OR CONSEQUENTIAL DAMAGES, WHETHER BASED ON CONTRACT, TORT, OR ANY LEGAL THEORY. PERKINELMER OPTOELECTRONICS' LIABILITY ON ANY CLAIM SHALL IN NO CASE EXCEED THE PRICE ALLOCABLE TO THE ITEM WHICH GIVES RISE TO THE CLAIM.

Quality Statement

PerkinElmer Optoelectronics' business is the design, development, and production of optoelectronic components and assemblies. Our development and manufacturing activities focus on achieving and maintaining consistent product quality and high levels of reliability. PerkinElmer produces devices and assemblies for the commercial, industrial, automotive, and medical markets.

PerkinElmer's commitment to quality emphasizes designed-in quality, problem prevention, and closed loop corrective action. This concept of quality is implemented through the use of fully documented procedures, in-process monitoring and process control (including SPC), and 100% production testing of devices using state-of-the-art automated test equipment. As a world class manufacturer, PerkinElmer's concept of product quality includes Total Quality Management (TQM) and Just In Time (JIT) delivery.

Quality is a measure of how well a device conforms to its specifications. Reliability is a measure of how well a device performs over time. PerkinElmer insures the reliability of its products by careful design and by the periodic testing of random samples taken from the manufacturing lines. Reliability tests include temperature cycles, thermal shock, room ambient life tests, elevated temperature life tests, high and low temperature storage, temperature/humidity tests, and water immersion.

PerkinElmer also performs special tests covering a wide range of environmental and life stress conditions to support non-standard, custom applications. The information generated not only assures the customer that the device will work well in a particular application, but also contributes to our data base for continual product improvement.

Driven by our goal of continuous improvement and the needs of customers, PerkinElmer runs an active product improvement program. PerkinElmer continuously evaluates new materials, manufacturing processes, and packaging systems in order to provide our customers with the best possible product.

PerkinElmer's quality works: we are an ISO 9000 and QS 9000 certified supplier (ship to stock - no inspection required) to a number of major customers.



Additional Sensor Products Catalogs

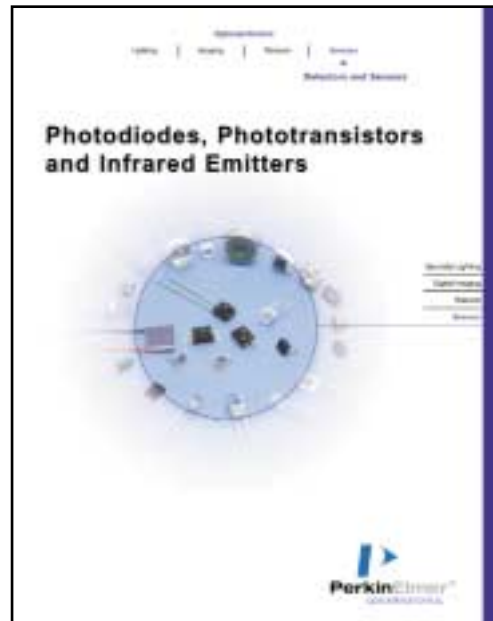
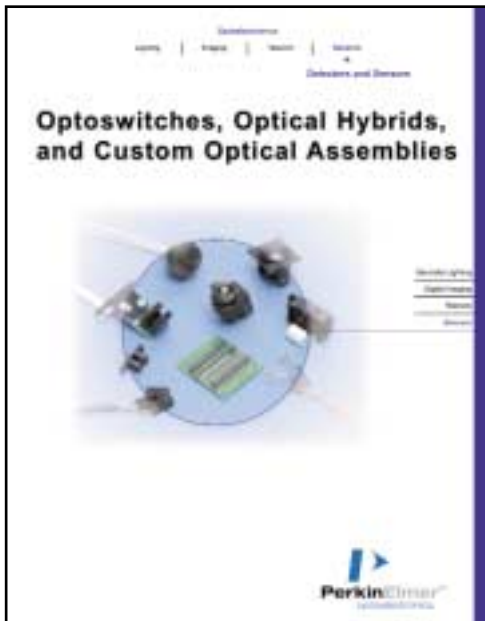

USA:
PerkinElmer Optoelectronics
10900 Page Avenue
St. Louis, MO 63132
Phone: (314) 423-4900
Fax: (314) 423-3956

Europe:
PerkinElmer Optoelectronics
Wenzel-Jaksch-Str. 31
D-65199 Wiesbaden
Germany
Phone: +49 611 492 0
Fax: +49 611 492 170

Asia:
PerkinElmer Optoelectronics
Room 1404, Kodak House II
39 Healthy Street East
North Point, Hong Kong
Phone: 852 2590 0238
Fax: 852 2590 0513

