



Application Note MTSAP1

I-V, C-V and Impedance Characterization of Photovoltaic Cells using Solartron Instrumentation

Introduction

Harnessing energy from the sun offers an alternative to fossil fuels. Photovoltaic cells have been in commercial use since the 1950's with Silicon devices accounting for over 90% of the market. However, much work is required to reduce the cost and improve the conversion efficiency if these devices are to compete with existing power generation technologies. In pursuit of this goal, new material candidates are being actively considered including amorphous Silicon, Cd/Te, polymer, CIGS and dye sensitised solar cells. This technical note describes how Solartron electrical characterization products can be used to evaluate solid-state and liquid electrolyte solar cells. Our discussions will include Current Voltage (I-V), Capacitance Voltage (C-V) and techniques based upon impedance.

Determination of solar cell parameters

Materials scientists often characterise solar cells in terms of simple circuit analysis; these typically include a p-n junction diode, a shunt resistance and a series resistor. Therefore, electrical characterization using a combination of DC and AC techniques allows the scientist to measure each of these components within the cell. Furthermore, different cell chemistries are at various stages of development and therefore some systems still require a significant effort in understanding the underlying physics of the devices. For example, polycrystalline Silicon is well understood as it has benefited from over 40 years R&D effort from the semiconductor industry. However, limitations due to cost and low theoretical efficiencies are driving scientists to seek new materials such as III-V compounds and polymeric systems in which the basic science is less mature. At present, scientists are engaged in a number of parallel strategies to improve the performance of next generation devices such as fundamental material characterization, multiple junction arrays and development of device structure. This necessitates the use of complex, accurate and flexible electrical characterization instruments that can meet the future demands of the scientists in this field.

The following section describes both DC and AC techniques that are offered by Solartron and how these techniques can be used to extract different pieces of information that are critical towards the development of more efficient and lower cost cells.



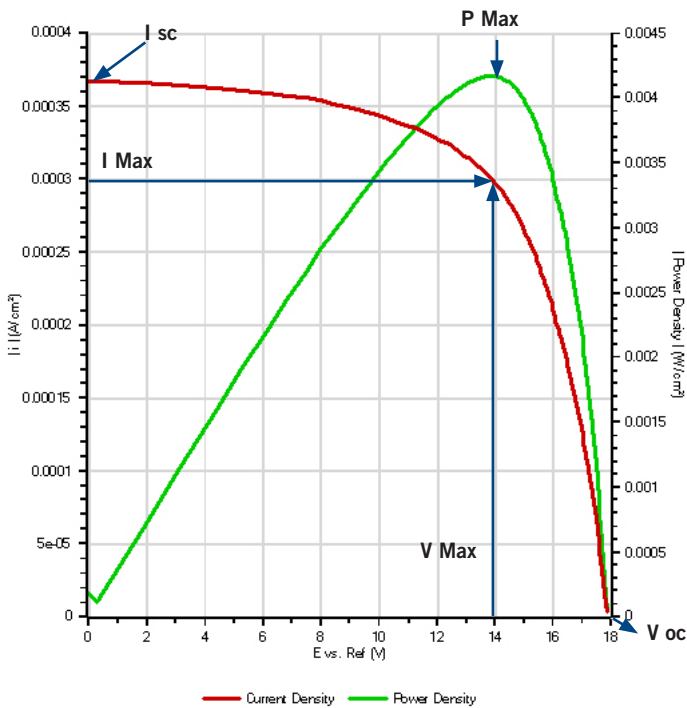

Figure 1: Forward bias I-V curve for a solid-state solar cell device including Power curve derived from I-V data

I-V Characterization

An understanding of the performance of a solar cell device can be gleaned with the I-V characterization technique. The voltage is ramped linearly or in staircase mode from the open circuit value (V_{oc}) to the Short Circuit Voltage (V_{sc}) and the generated current is measured. Depending upon the parameter of interest, the I-V characteristics are either measured under illumination at different light intensities or in the dark. An I-V curve of an 18 V solar cell under ambient illumination is presented in Figure 1

This simple result contains a large amount of useful information and the following parameters can be extracted from this data including;

- **I_{sc}**, Short Circuit Current (J_{sc} , short circuit current density)
- **V_{oc}**, Open Circuit Voltage
- **P_{max}**, Maximum Power Point
- **I_{max}**, Current at P_{max}
- **V_{max}**, Voltage at P_{max}
- **FF, Fill Factor** = $P_{max}/V_{oc} \cdot I_{sc}$
- **η , conversion efficiency** = $P_{max}/E A_c$ where E is the input light intensity and A_c is the total surface area.

A number of features are included in the Solartron software that allow the user to precisely control the applied waveform to the cell (refer to Figure 2). Highlights of these features include;

- Ability to apply linear and triangular voltage waveforms. Some cells exhibit a dependency on the sweep direction and this can be determined by cycling the voltage in both the forward and reverse directions
- Staircase voltage ramps techniques allowing users to look at the step delay response of the cell. The user can define where the current is sampled on the step.

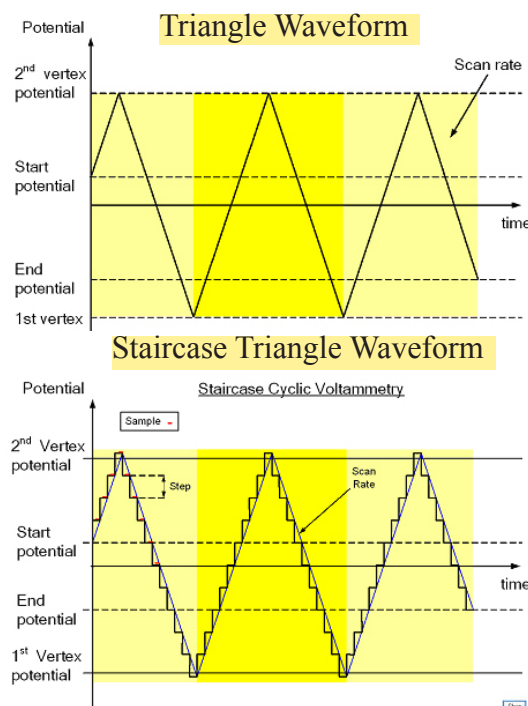

Figure 2a and b Description of a Triangle Voltage Waveforms (linear and staircase) for I-V characterization. Start, 1st vertex, 2nd vertex and end potentials are defined by the end user in the software. Multiple cycles can be used to determine if the system is stable under a varying load. Scan rates from $100 \mu\text{Vs}^{-1}$ to 1M Vs^{-1} are available with data acquisition up to 1 Million samples per second.

- Pulse potential techniques with ability to define pulse height and pulse width. This can be used to understand the dynamic response of the cell under rapid changes in load.
- Ability to apply/measure up to ±100 V DC steps (with hardware option)
- Ability to measure from fA's to 20 Amps (with suitable hardware options) allowing characterization of low leakage currents or performance under high loads.
- A range of analytical tools are provided including linear regression analysis. This is useful for determining the shunt resistance under dark conditions (see Figure 3)

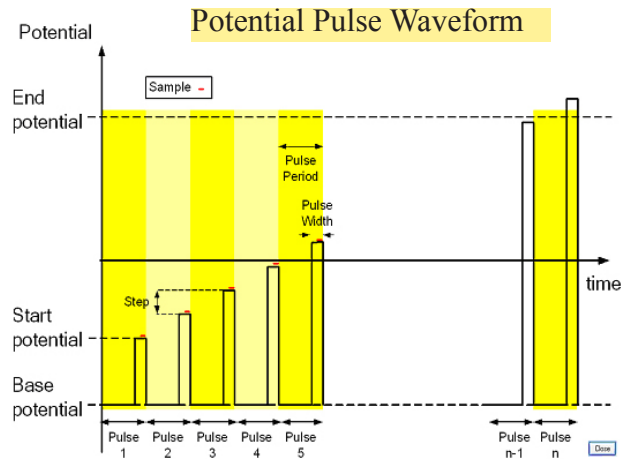

Figure 2c Potential pulse waveform. The user has the ability to define the pulse period, step height and pulse width. Minimum pulse width = 1 μs

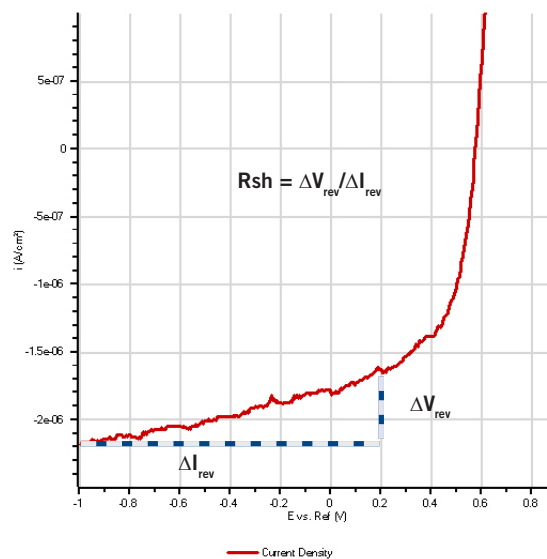

Figure 3 : Reverse Bias characteristics of an 18 V PV cell indicating method of calculating the shunt resistance. Analysis can be performed in software with regression tool. Note that for very low leakage current devices, Solartron systems have options to increase current resolution down to 0.15 fA.

C-V characterization

Capacitance voltage measurements are used to characterise fundamental properties of solar cells including an estimate of the charge carrier density and the drive level capacitance profile. A Mott-Schottky plot of a Silicon solar cell is presented in Figure 4. The charge density distribution can be derived from these results using the following expression,

$$N_c(W) = \frac{2}{qK_s \epsilon_0 A^2} \left[\frac{d(1/C^2)}{dV} \right]$$

Figure 4. Mott-Schottky plot of solid-state solar cell derived from C-V measurements.

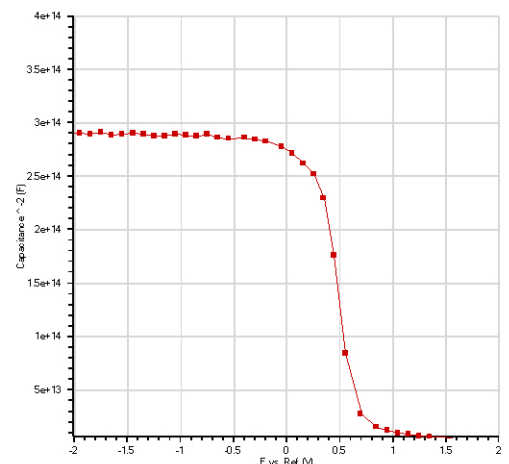

where N_c (W) is the charge density, q is the charge on an electron, K_s is the relative permittivity, A is the surface area, ϵ_0 is the permittivity of free space, $d(1/C^2)/dV$ is the slope derived from the Mott-Schottky plot.

Key features of the Solartron systems for C-V measurements include;

- Ability to measure C-V profiles from ± 100 V DC (with hardware options)
- User can define AC stimulus level and frequency that is suitable for the device under test. In addition to impedance magnitude, phase is measured to verify that results are capacitive in nature i.e. $\theta \sim 90^\circ$. Furthermore, the ability to vary the AC stimulus level can be used to derive the drive-level capacitance profile (DLCP). DLCP experiments can be automated in software.
- Choice of linear or staircase ramp techniques with user defined ramp rates.

Characterization using Wide Bandwidth Impedance/Admittance spectroscopy

Impedance measurements of solar cells are performed over a wide range of frequencies which typically cover 1 MHz to < 0.1 Hz. This technique has received considerable attention within the academic community. It has helped researchers build equivalent circuits that represent the processes occurring in solar cell device over 7 decades of frequency. The benefits of this technique include;

- Ability to separate processes in the frequency domain including series resistance, chemical capacitance, recombination resistance and the impedance of blocking electrode contacts
- All parameters can be determined in a single experiment
- Data can be analysed using equivalent circuit analysis and processes are represented by simple passive circuit elements. Such models are used to quickly determine the processes that limit the performance of the device.

An example of a wide spectrum impedance sweep of a solar cell under illumination at varying drive voltages is presented in Figure 5.

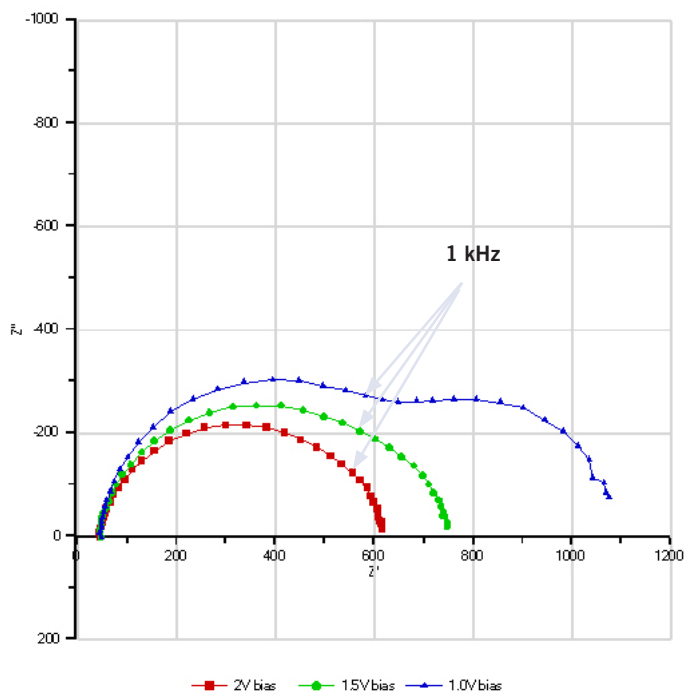

Figure 5: Nyquist / Cole-Cole diagrams of a solid-state solar cell under varying DC bias (note this experiment was performed under illumination). AC stimulus level was 100 mV.

In this example, the impedance is presented in the Nyquist or Cole-Cole format in which the imaginary and real impedances are plotted at discrete excitation frequencies. The frequency was swept from 200 kHz to 20 Hz using Solartron's Single Sine Correlation technique. For many cells, it is necessary to sweep the frequency below 1 Hz as important information about the inductive behaviour of cells is contained in the region of approximately 100 Hz to 10 mHz. In this particular example, inductive behaviour was not observed at low frequencies.

There are a number of alternative methods of presenting the impedance data which are supported in Solartron software including, Bode (Impedance, Phase vs. Frequency), complex capacitance and permittivity vs. Frequency, AC voltage and AC current vs. frequency. The use of these methods of data presentation are presented elsewhere in the literature but all have been shown to be useful in the development of our understanding of the fundamental electrical properties of the solar cell.

Some interesting observations are made with the example presented in Figure 5. As the bias voltage approached the inversion region for the device (see Figure 4), the impedance spectrum clearly shows the presence of two time constants (indicated by two semi-circle arcs at $V = 1.0V$). The presence of the low frequency arc (freq < 1 kHz) possibly reflects the influence of the recombination impedance upon the operation of the device at low drive voltages. As the drive voltage increased, the influence of this process became less pronounced. However, this information does allow the engineer to understand and characterise the efficiency of the current collecting materials and the recombination kinetics within the cell and make the necessary improvements. Indeed, it is also important to stress that such analysis and interpretation of the operation of the device would not be possible if the experiment had been limited to 1 kHz.

Several equivalent circuit models have been proposed in the literature that represent the underlying processes within solar cells. Equivalent circuit analysis is offered with Solartron software and a generalised circuit that was created within the software is shown in Figure 6. A number of simple and distributed elements are available which have been developed to model many physical processes such as Warburg and Gerischer elements. However, for the purposes of this exercise, the model only contains simple resistors and capacitors. The user has the options to model the frequency dependence of the impedance of the circuit in simulation or fitting mode. The simulation mode is a useful tool for the scientist to evaluate if the proposed circuit accurately models the impedance behaviour of the real device. In fitting mode, the values of the components are adjusted to fit the real data. The quality of fitting depends upon the user enter reasonable initial values for R and C.

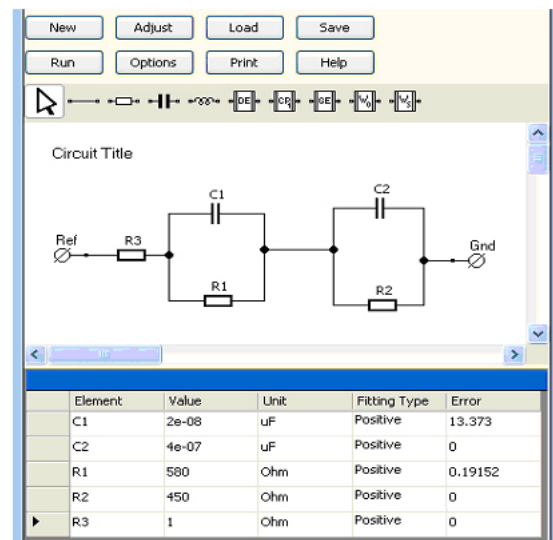

Figure 6: Equivalent Circuit Modeling tool. Elements can be selected from a drag and drop menu. The circuit shown in this figure was used to model the impedance response of the solar cell from 200 kHz to 100 Hz.

An example of the comparison between theory and experiment is shown in Figure 7. There is reasonable agreement between the model and the real data although improvements to the model will improve the relationship between theory and experimental data. The model assumes a recombination resistance and chemical capacitance (R_1 and C_1) and contact parameters (R_2 and C_2). At high drive voltages, the time constants are similar (the relationship $R_1C_1/R_2C_2 \gg 1$ is valid) and therefore the impedance plot shows apparently one time constant. This condition is not met when the drive voltage approaches the inversion region where $R_2C_2 \ll R_1C_1$. This might indicate that recombination kinetics dominate the performance of the cell within this region although further experimentation would be required to validate this assumption.

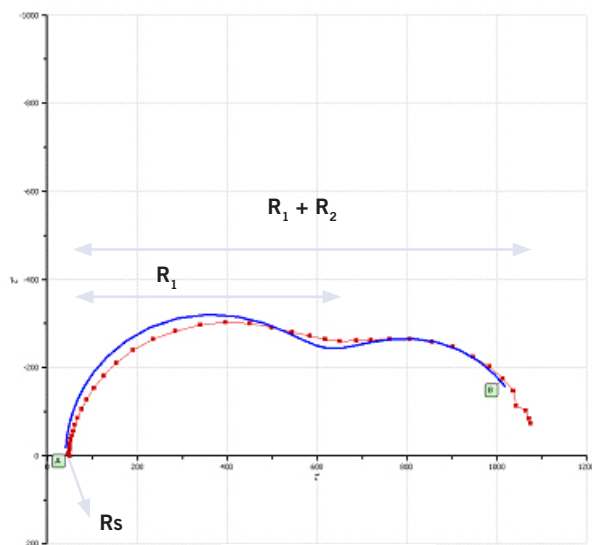

Figure 7: Comparison between the theoretical impedance response of the circuit shown in Figure 6 (blue line) vs. the real cell response (red line and dots). There is reasonable agreement between theory and experiment. The impedance values of R_1 (contact) and R_2 (recombination) are shown on the plot. In addition, the series resistance R_s can be calculated by determining the impedance at the point in which the high frequency measurement intercepts the real (Z') axis.

Summary of Measurement Capabilities

This section briefly describes the measurement capabilities offered by Solartron. There are a number of instruments available that are suited towards this application area. Table 1 captures the highlights of Solartron measurement ranges and the information the techniques provide.

Technique	Parameters	Voltage Range	Current Range	Frequency Range
I-V (linear, staircase, pulse, differential pulse)	Power, R_s , R_{sh} , FF, efficiency, V_{oc} , V_{sc} , I_{oc} , I_{sc}	1 μ V resolution to kV (with external amplifiers)	± 0.15 fA resolution to 25 A	NA
C-V (linear or staircase ramp with user defined ac stimulus level)	Mott-Schottky, N_c , N_{drive} level	1 μ V resolution to kV (with external amplifiers)	± 0.15 fA resolution to 25 A,	1 MHz to 10 μ Hz
Impedance (Single Sine, Multisine FFT)	Phase, Impedance, Permittivity (real and complex), Capacitance (real and complex,	1 μ V resolution to kV (with external amplifiers)	± 0.15 fA resolution to 25 A. 100 $\mu\Omega$ to 100 T Ω	32 MHz to 10 μ Hz

Table1: Techniques and information obtainable with Solartron Instrumentation. Brief measurement capabilities are included

Conclusion

This technical note described how Solartron instrumentation can be used to characterize the electrical properties of a Solar Cell. Common techniques such as I-V, C-V and Impedance/Admittance spectroscopy were shown to yield valuable information regarding the devices under test. The software solutions allow end users to quickly combine DC and AC measurements and control complex experiments without the need to develop their own test programs. The software features are further enhanced with the addition of powerful fitting techniques such as regression analysis and equivalent circuit analysis which are used to model the underlying processes of the materials.



Solartron Analytical's Quality System is
approved to
BS EN ISO 9001:1994



FM01709

...part of **AMETEK**® Advanced Measurement Technology

UNIT B1 ARMSTRONG MALL
SOUTHWOOD BUSINESS PARK
FARNBOROUGH, GU14 0NR
UNITED KINGDOM
Phone: +44 (0) 1252 556 800
Fax: +44 (0) 1252 556 899

801 SOUTH ILLINOIS AVENUE
OAK RIDGE
TN 37831-2011
USA
Phone: +1 865 425 1360
Fax: +1 865 425 1334

Visit our website for a complete list of our global offices and authorized agents

solartron.info@ametek.com

www.solartronanalytical.com