



## 618XR RAPISCAN

A VERSATILE, MOBILE AND POWERFUL X-RAY INSPECTION SYSTEM FOR SCREENING IN SMALL SPACES

- ▶ VERSATILE SCREENING SYSTEM
- ▶ COMPACT DESIGN
- ▶ PORTABLE
- ▶ NETWORK ENABLED
- ▶ COST EFFECTIVE

### STANDARD FEATURES

- Multi energy imaging (4 Color)
- View previous/next bag
- Manual image archive
- Configurable image processing keys
- Baggage counter
- Date / time display
- Search indicator
- UPS (Uninterrupted Power Supply)
- Flat panel monitor

### STANDARD IMAGE PROCESSING FUNCTIONS

- Crystal clear™
- Black and white
- Organic / inorganic stripping
- Inverse video
- High penetration
- Pseudo color
- Low penetration
- Variable edge enhancement
- Variable color stripping
- Variable gamma
- Variable density
- Dynamic continuous zoom & panning
- Fixed zoom (64x)

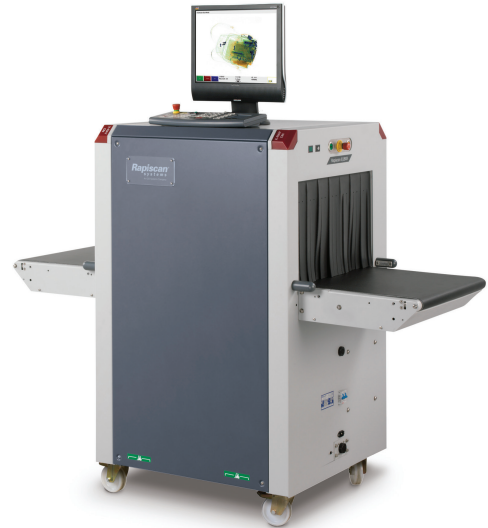

TUNNEL OPENING (WXH):  
550 X 360 MM (21.7 X 14.2 IN)

THE RAPISCAN 618XR IS A COMPACT AND VERSATILE X-RAY SCREENING SYSTEM WITH EXCEPTIONAL IMAGE QUALITY AND EXCELLENT DETECTION CAPABILITIES. THE 618XR IS DESIGNED FOR RAPID RELOCATION AND CAN BE WHEELED THROUGH NARROW DOORWAYS, MAKING IT AN EXCELLENT SYSTEM FOR SCHOOLS, HOTELS, CONVENTION CENTERS AND EVENTBASED SECURITY ENVIRONMENTS.

### DETECTION OF EXPLOSIVES AND NARCOTICS ALERT

Target™ and NARCScan™ are designed to assist operators in the detection of a range of explosives and narcotics respectively in real time during the scanning process by marking a potential threat on the X-ray image. Rapiscan detection algorithms are based on regulatory material analysis techniques.

### EASE OF USE PROVIDING HIGHEST THROUGHPUT

With over 13 image processing tools and detection alert algorithm functions, the feature rich software allows the operator to more easily and accurately search for contraband.

### REGULATORY COMPLIANCE

Rapiscan 618XR performance is in full compliance with the European Union regulations (EC) No. 300/2008, (EU) No. 2015/1998 and Commissions Decision C (2015)8005 for aviation security.





## 618XR RAPISCAN

### PHYSICAL SPECIFICATIONS

Dimensions:	Length: 1,662 mm (65.4 in.) Width: 735 mm (28.9 in.) Height: 1,366 mm (53.8 in.)
Tunnel size:	550 mm (W) x 360 mm (H) (21.7 x 14.2 in.)
Conveyor speed:	0.20 m/sec (39.4 ft./min)
Conveyor load (Max):	165 Kg (364 lbs)
Conveyor height (Approx.):	830 mm (32.7 in.)
Weight (Approx.):	Net: 425 Kg (937 lbs)
System power:	115/230 VAC +/-10%, 60/50Hz

### X-RAY GENERATOR AND IMAGE PERFORMANCE<sup>(1)</sup>

Steel penetration:	28 mm guaranteed; 30 mm typical
Wire resolution:	38 AWG guaranteed; 40 AWG typical
Material separation:	Low Z, Medium Z, High Z to 0.5 Z accuracy
Generator cooling:	Sealed oil bath with forced air
Anode voltage:	140kV
Tube current:	0.7 mA
Orientation:	Vertically upward

### OPERATING ENVIRONMENT

Storage temperature:	-20°C to 50°C
Operating temperature:	0°C to 40°C
Relative humidity:	5 to 95% non-condensing

### PROTECTION CLASS

System:	IP20
Operator control panel:	IP43 <sup>2</sup>

### GOVERNMENT REGULATORY

Regulation (EC) No. 300/2008 Compliant  
 Regulation (EU) No. 2015/1998 Compliant  
 EU Commissions Decision (EU) C(2015) 8005 Compliant  
 French Civil Aviation Authority (STAC) Certified

### HEALTH & SAFETY

Rapiscan Systems' cabinet X-ray products comply with all applicable U.S. FDA and equivalent international regulatory agency requirements, contained in the cabinet X-ray radiation safety performance standard [21 CFR 1020.40] and the general performance standard [21 CFR Part 1010] as well as IEC standard 61010-2-091. Rapiscan baggage and parcel inspection systems radiation emission leakages are well below the required regulatory limits with less than 1 µSv/hr at 10 cm from all surfaces of cabinet X-ray.

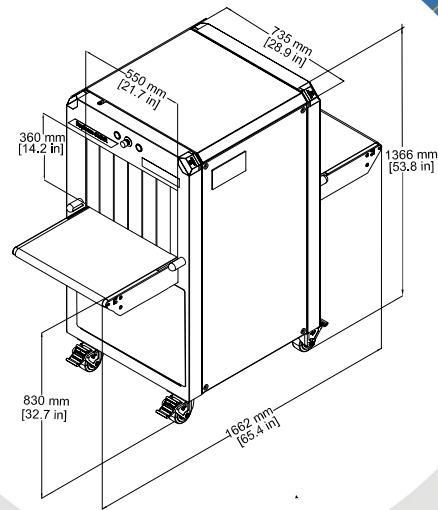

### OPTIONS AND ACCESSORIES

- Explosives detection alert (Target)
- Narcotics detection alert (NARCScan)
- Density threshold Alert (DTA)
- Threat image projection (TIP)
- Threat image projection network (TIPNet)
- Remote image archive review (NETView)
- Network X-ray management automation and link system (NEXLink)
- Multi-system network display station (NDS)
- Automatic image archiving
- Enhanced image archiving
- Operator training program (OTP)
- Manual scan
- Operator pedestal
- Foot mat
- Optical operator presence sensor
- Smartcard login
- Power conditioner
- Conveyor accessories
- Universal printer support

(1) Stated performance as measured by Rapiscan Imaging Validation Test Kit.  
 (2) With optional replaceable cover.

With continual development of our products Rapiscan Systems reserves the right to amend specifications without notice. Product pictures are for general reference. Please note that due to US laws and regulations, not all Rapiscan products are available for sale in all countries without restriction. Please contact your Rapiscan Systems sales representative for more information.

### HTDS

Parc d'Activités du Moulin de Massy - 3 rue du Saule Trapu  
 BP246 - 91882 Massy Cedex France  
 Tel : +33 (0) 1 64 86 28 28 - Fax : +33 (0) 1 69 07 69 54 - info@htds.fr - www.htds.fr

HTDS Algeria: +213 232 384 01/02

HTDS Morocco: +212 222 749 59

HTDS Egypt: +202 229 053 06

HTDS Lybia: +218 91 69 50 70 8

HTDS Madagascar: +261 34 40 664 72

HTDS Tunisia: +216 70 836 961