



CLASSIC CEIA

WALK-THROUGH METAL DETECTOR

- HIGH LEVEL OF DETECTION UNIFORMITY
- LEADING EDGE TECHNOLOGY
- QUICK INSTALLATION
- SUITABLE FOR PORTABLE APPLICATIONS
- NO MAINTENANCE REQUIRED

LIGHTWEIGHT AND COMPACT, THE CLASSIC METAL DETECTOR IS PORTABLE AND USABLE IN ALL ENVIRONMENTS

The Classic Metal Detector combines the required Security with a high level of operating efficiency. The leading edge technology features a high flow rate of people through the gate with a minimum number of nuisance alarms (with personal items for example such as coins, keys or belt buckles can pass through the magnetic field without causing an alarm.

The Classic Metal Detector is compact and lightweight, making this portable unit adaptable to any surroundings. The patented cylinder design is aesthetically suitable for the most discrete applications.

This security equipment does not require any special training for normal use, it is the most "user friendly" walk-through metal detector in the industry.



THE CLASSIC IS A WALK-THROUGH METAL DETECTOR DESIGNED AND ENGINEERED TO MEET THE SPECIFIC SECURITY NEEDS OF PUBLIC FACILITIES SUCH AS SCHOOLS, HOTELS, AMUSEMENT PARKS AND CITY HALLS.

The column construction, both attractive and compact, allows it to be inserted with ease into public environments such as, for example, schools and discotheques. The Classic Metal Detector has an extremely competitive price/performance ratio.



Specially indicated for all Installation with a limited ceiling height, classic/navy is equipped with an electronic control unit in an ip65 stainless steel housing.

BELOW THE ALARM LIMIT

- Small metallic mass
- Average metallic mass

BELOW THE ALARM LIMIT

- Average metallic mass
- Large metal mass

Green or red signals proportional to the mass of the object in transit.



CLASSIC CEIA

SPECIFICATIONS

Main features	Digitally-adjustable sensitivity with a wide range of values
	Control unit incorporated into the detector
	Programming access protected by hardware key
	No initial or periodic calibration
	All functions programmable and controlled by a microprocessor
	Easy maintenance: modular control unit for a rapid replacement
	Professional high integration and reliable electronics
	Color: light grey RAL 7040
Installation data	Multiple installations: automatic synchronization between two or more metal detectors with a mutual distance of down to 2" (5 cm) without the use of cables
	Power supply: 100-240V~, -10/ +15%, 47-63Hz, with universal Power supply adapter
	Operating temperature: -20°C to +70°C
	Storage temperature: -35°C to +70°C
Alarm modes	Relative humidity: 0 to 95% (without condensation)
	High intensity display
	Green and red metering signals proportional to the mass of the object detected
	High acoustic intensity alarm signal
Certification and conformity	Volume and tone of alarm signal can be programmed
	Complies with regulations relating to pacemakers, defibrillators or other vital support systems, pregnant women and magnetic storage media (CD, audio cassettes, video cassettes and similar)
	Conforms to the current International Security Standards for Walk-Through Metal Detectors

OPTIONS AND ACCESSORIES

Module MBSU -1:

Transportable device for supplying power to metal detectors with backup batteries



Metal detector divesting table



HTDS

Parc d'Activités du Moulin de Massy - 3 rue du Saule Trapu

BP246 - 91882 Massy Cedex France

Tel : +33 (0) 1 64 86 28 28 - Fax : +33 (0) 1 69 07 69 54 - info@htds.fr - www.htds.fr

HTDS Algeria: +213 232 384 01/02

HTDS Morocco: +212 222 749 59

HTDS Egypt: +202 229 053 06

HTDS Lybia: +218 91 69 50 70 8

HTDS Madagascar: +261 34 40 664 72

HTDS Tunisia: +216 70 836 961



DIMENSIONS

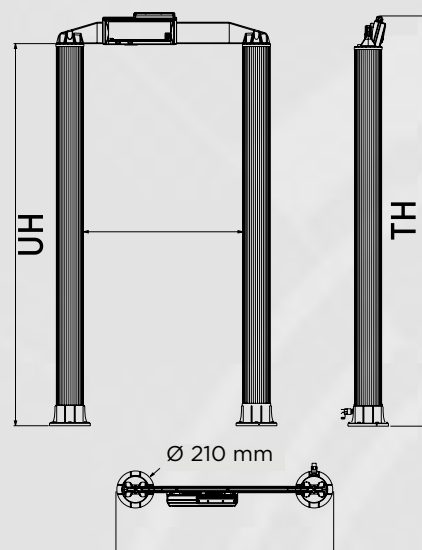

	CLASSIC	CLASSIC/ NAVY
UW	720/820* mm	720/820* mm
UH	1965 mm	1835 mm
TH	2152 mm	2000 mm

* Available on request