



ORION 920DX RAPISCAN

BAGGAGE AND SMALL PARCEL
INSPECTION SYSTEM

- INDUSTRY BEST PENETRATION,
WIRE & SPATIAL RESOLUTION
- EXPLOSIVES & NARCOTICS DETECTION
- LOW DENSITY IMAGE ENHANCEMENT
- MATRIXING, NETWORKING & REMOTE
VIEWING

SPECTRUM 4-COLOR IMAGING

920DX can present images to the operator in the Classic 4-color and the new proprietary Spectrum 4-color (SP4) option providing superior image, allowing improved security by quick and accurate identification of threats and increase in throughput.

DUAL MODE Z_{EFF}

This feature aids the operator in quick identification of organic materials, either in Range Mode which highlights areas based on operator selected Z-effective values of 7, 8 or 9, or in Interactive Mode which gives the operator the option to display the Z-effective number of a selected pixel.

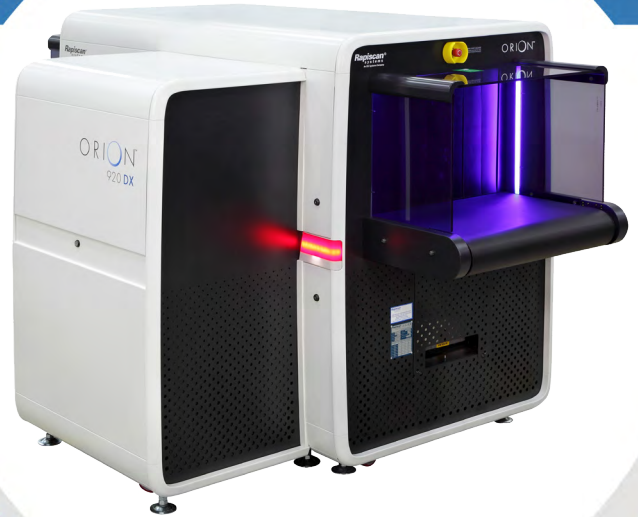

TUNNEL OPENING (W X H):
640 MM X 430 MM

THE NEW 920DX IS A HIGH PERFORMANCE 640MM BY 430MM TUNNEL DUAL VIEW CHECKPOINT SCREENING SYSTEM WITH EXCELLENT THREAT DETECTION ALERT CAPABILITIES.

EXPLOSIVES AND NARCOTICS DETECTION

Target and NARCScan are designed to detect a wide range of explosives and narcotics respectively in real time during the scanning process by marking a potential threat on the X-ray image. Rapiscan® Systems detection algorithms are based on regulatory approved material analysis techniques.

EUROPEAN AVIATION COMPLIANCE

920DX performance is in full compliance with the mandatory regulations (EC) No. 300/2008, (EC) implementing regulation 1998/2015 and update 815/2017, EC implementing decision 8005/2015 and update 3030/2017 for aviation security in the European Union.



ORION 920DX RAPISCAN

PHYSICAL SPECIFICATIONS ¹

Dimensions	L : 2316 mm
	W : 1503 mm
	H : 1390 mm
Tunnel size	W : 640 mm
	H : 430 mm
Conveyor height	813 mm
Weight	897 Kg

ENVIRONMENT & POWER

Storage temperature	-20°C to 50°C
Operating temperature	0°C to 40°C
Relative humidity	5 to 95% non-condensing
System power	100/110/120/200/208 /220/230/240 VAC ± 10%

PERFORMANCE ²

Conveyor speed ¹	0.22 m/sec
Conveyor load ¹	165 Kg
Steel penetration	41 mm typical, 40 mm standard
Wire resolution	41 AWG typical, 40 AWG standard
Spatial resolution	0.8 mm vertical & horizontal

X-RAY GENERATOR

Anode voltage	160kV
Orientation	Vertically Upward and Horizontal

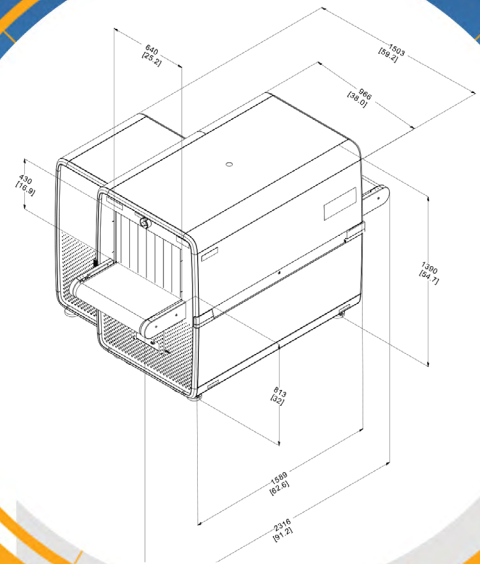

KEY FEATURES AND OPTIONS

- Explosive threats, narcotics & density alerts
- Spectrum 4
- 17 Image processing functions
- SINERGY low density enhancement
- Dual Mode Z-effective
- CrystalClear™
- Automatic, Enhanced Image Archiving
- E.U. Approved Threat Image Projection
- Remote Status Monitoring
- Remote Archive Review
- Multi-System Alarm Resolution Network
- Multiplexing and Matrixing
- Tray Return System Compatible
- 13 Languages
- 64-bit Operating System

1. Approximate Values
2. Stated performance as measured by Rapiscan® Imaging Validation Test Kit

HTDS

Parc d'Activités du Moulin de Massy - 3 rue du Saule Trapu
BP246 - 91882 Massy Cedex France
Tel : +33 (0) 1 64 86 28 28 - Fax : +33 (0) 1 69 07 69 54 - info@htds.fr - www.htds.fr

HTDS Algeria : +213 232 384 01/02

HTDS Morocco : +212 222 749 59

HTDS Egypt : +202 229 053 06

HTDS Lybia : +218 91 69 50 70 8

HTDS Madagascar : +261 34 40 664 72

HTDS Tunisia : +216 70 836 961