

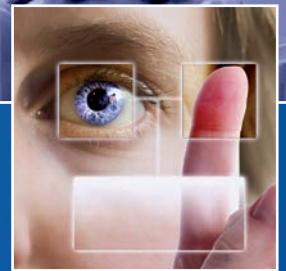

ENG

X-ray Inspection System



DYLOG[®]
H I T E C H



X-ray Inspection System

DYMOND SERIES CONVEYOR BELT MACHINE

Advanced components and innovative design, together with powerful and intuitive software, let Dymond machines adapt to the ever more rigorous standards set by food and pharmaceutical companies.

ADVANTAGES OF X-RAY INSPECTION

This is a **non destructive analysis** which, without altering the chemical composition or organoleptic properties of the product in any way, detects contaminants (in any type of container or package) and verifies the product's completeness and conformity.

Every contaminant with a higher density than that of the inspected products (metals, glass, bones, stones, shells, ceramics, PVC, Viton®) can be identified.

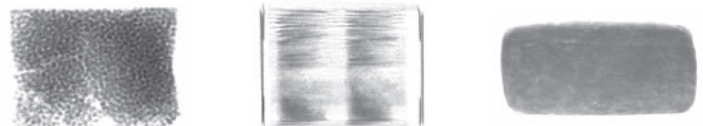
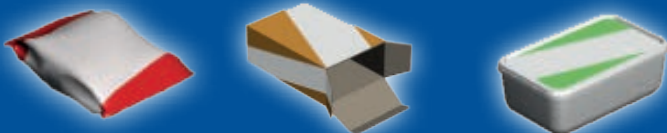



HARDWARE

X-ray tube - the reduced focal spot and high quality of the focal spot ensure an excellent, long-term performance.

Plus the **air cooling system** means the machine can operate in an extensive temperature range, without having to install an external water cooler.



The **belt length** is entirely configurable, based on customer requirements and available space. Thanks to the use of a new **motor-driven drum system**, the length can be reduced to 1 m and the belt combined with existing belts, without difficulties caused by the size of normal external motors.

The main components (belt, shutters, generator, detector) can be **quickly and simply removed**, thanks to the entirely new design.



A complete range of **reject systems and modular collection boxes** ensure an optimal solution for any type of product.

The new **Clear-View** version is available, with front hatch and glass-lead point of view to see all products that pass through the inspection compartment.



SOFTWARE

Dylog software for contaminant detection guarantees a high level of performance; the **new filtering technology and parallel image processing** ensure noise-free, contrasted images, increasing the scanning speed.

It is also possible to **identify missing product parts and check total or partial product weight**, with screens that can easily be configured.

Multi-line inspection, for up to 8 lines, ensures total flexibility in ejecting contaminated products.

Remote control of the machine is available, along with a **5-level password-protected system**, for a large number of operators to work, each with his/her own password.

Production and machine use data are stored on a redundant basis, to guarantee the **utmost security** and are **easy to consult**, with the automatic production of reports.

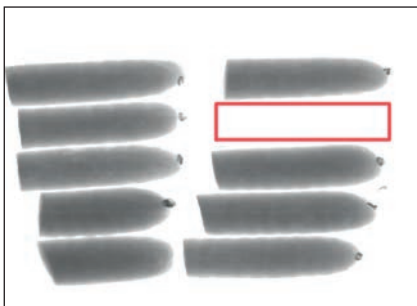

TECHNICAL FEATURES

Power	[75 kV - 2.0 mA] or [90 kV - 3.5 mA]
Scan rate of sensor	up to 2800 lines/second
Sensor resolution	0.8 mm
Belt speed	10 – 80 m/min (drum motor)
Curtains	Unleaded FDA approved
Certifications	CE, UL
Safety switches - interlock	SIL 3. Category IV PL E, magnetic
HMI	Touchscreen 15"
Languages	English, Italian, French, German, Spanish, Norwegian, Chinese, Hungarian, Polish, Korean
Operating temperature	+5°C to +40°C with air conditioner
Relative humidity	20% - 90% (non-condensed)
Power supply	230 VAC ±10% (standard)
Compressed air	5.5 -6.9 bar
Cooling	500W air conditioner (IP34 or Nema4x-IP65)
USB port	yes - external
Network outlet	Ethernet
Radiation protection	FDA CFR 21 part 1020,40
International Protection Rating (IP)	IP34 with standard air conditioner, IP65 with Nema4x air conditioner

OVERALL DIMENSIONS

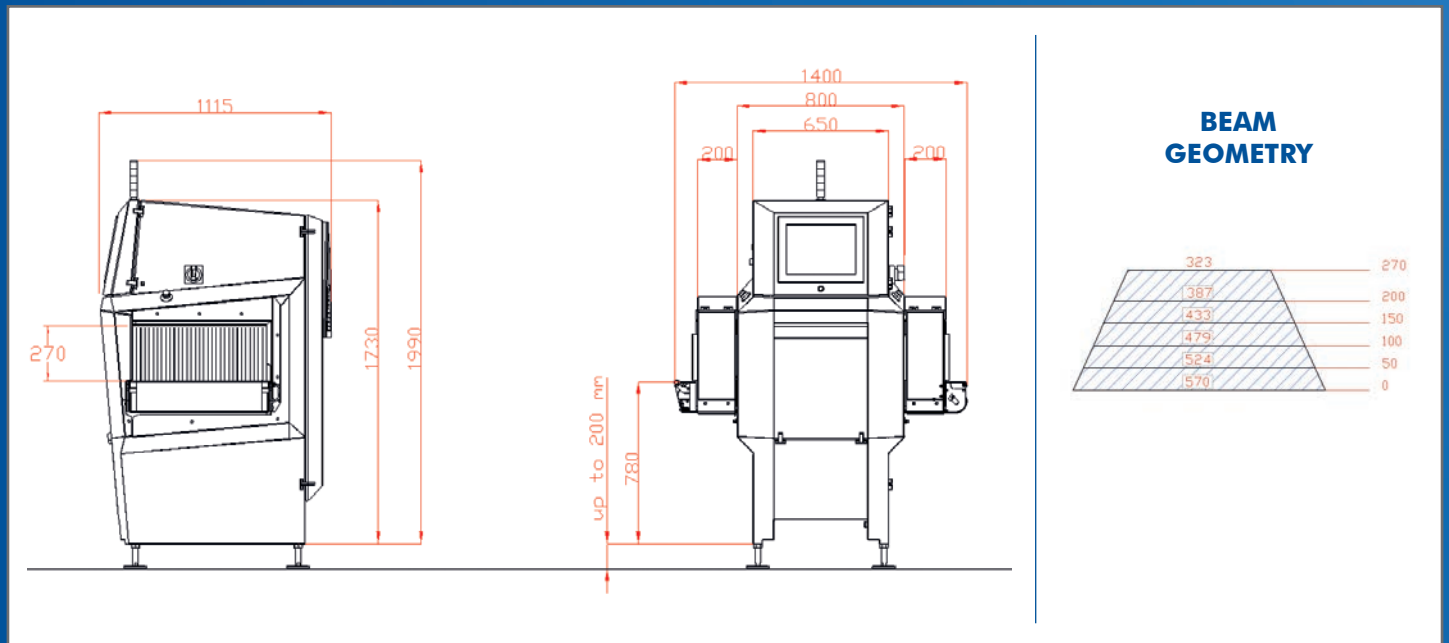

www.dyloghitech.com - hitechsales@dylog.it - Tel. +39 011 6938.406 - Fax +39 011 6938.364