

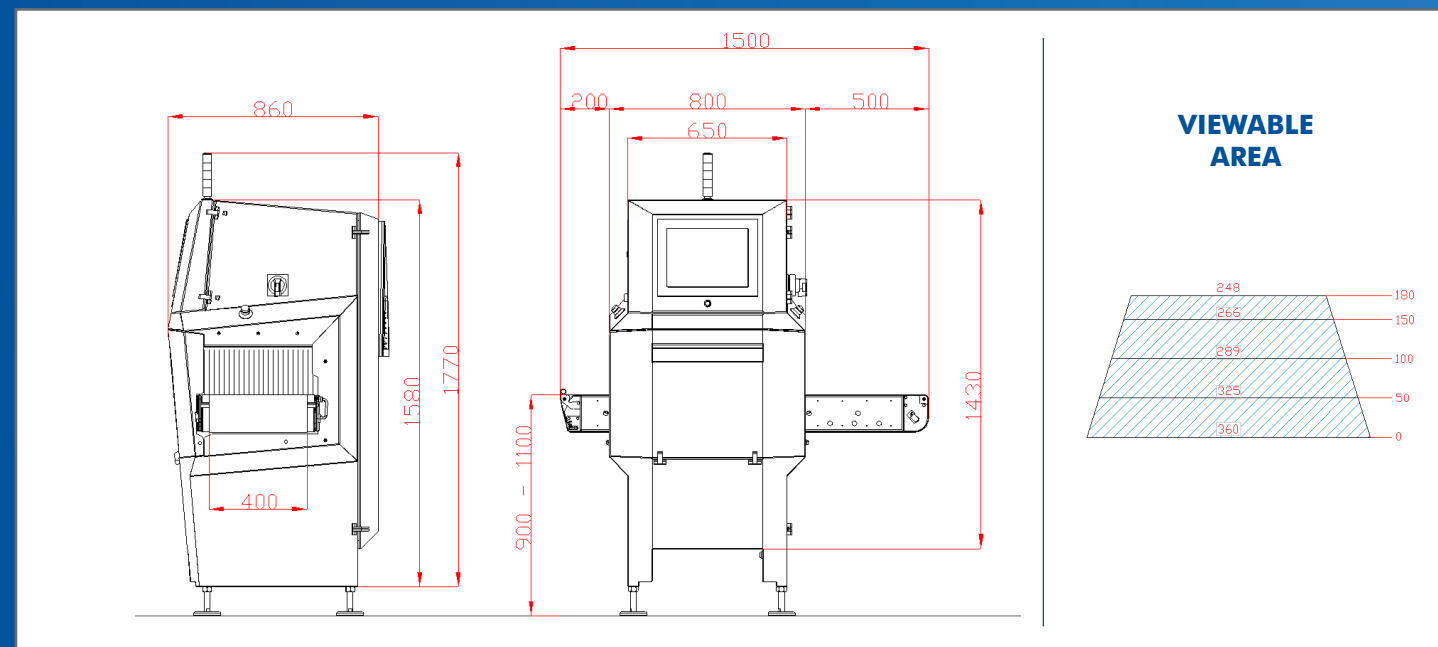

TECHNICAL FEATURES

Power	100W or 200W
Sensor scan rate	up to 2800 lines/second
Sensor resolution	0.8 or 0.4 mm
Belt speed	10 – 80 m/min (drum motor)
Curtains	Unleaded FDA approved
Certifications	CE, UL
Safety switches - interlock	SIL 3. Category IV PL E, magnetic
HMI	Touchscreen 15"
Languages	English, Italian, French, German, Spanish, Norwegian, Chinese, Hungarian, Polish, Korean
Operating temperature	+5°C to +40°C with air conditioner
Relative humidity	20% - 90% (non-condensed)
Power supply	230 VAC ±10% (standard)
Compressed air	5.5 -6.9 bar
Cooling	500W air conditioner (IP34 or Nema4x-IP65)
USB port	yes - external
Network port	Ethernet
Radio protection	FDA CFR 21 part 1020,40
International Protection Rating (IP)	IP34 with standard air conditioner, IP65 with Nema4x air conditioner

OVERALL DIMENSIONS



ENG

X-ray Inspection System



www.dylog.it - hitechsales@dylog.it - Tel. +39 011 6938.406 - Fax +39 011 6938.364

DYLOG[®] X-ray foreign body detection
HITECH

DY80ENG1014

DYLOG[®]
HITECH



X-ray Inspection System

DYMOND SERIES CONVEYOR BELT MACHINE

Advanced components and innovative design, together with powerful and intuitive software, let Dymond machines adapt to the ever more rigorous standards set by food and pharmaceutical companies.

ADVANTAGES OF X-RAY INSPECTION

This is a **non destructive analysis** which, without altering the chemical composition or organoleptic properties of the product in any way, detects contaminants (in any type of container or package) and verifies the product's completeness and conformity. Every contaminant with a higher density than that of the inspected products (metals, glass, bones, stones, shells, ceramics, PVC, Viton®) can be identified.



HARDWARE

X-RAY TUBE - the small focal spot and the high quality of the tablet element provide long-lasting, excellent performance. Equipped with the AIR COOLING system, the machine can work in a wide range of temperatures without needing an outside air chiller.



The BELT LENGTH is completely configurable, depending on the customer's requirements and the space available. The new system with DRUM MOTOR allows you to reduce the length of the belt to 1m and to join it with existing ones without problems typically caused by the size of normal external motors.



The main components (BELT, CURTAINS, GENERATOR and SENSOR) can be removed simply and quickly thanks to the completely new design.

A complete range of MODULAR WASTE SYSTEMS AND COLLECTION BOXES offers you the ideal solution for any type of product.

The new CLEAR-VIEW version has a front lead glass window so you can see the products as they move through the inspection tunnel.



SOFTWARE

Dylog contaminant detection SOFTWARE guarantees high performance. New filtering technology and parallel image processing provide clear, high-contrast images, without noise, and with faster scanning speed.

Missing product parts can be identified and the total or partial weight of the product can be checked thanks to intuitive, configurable screens.

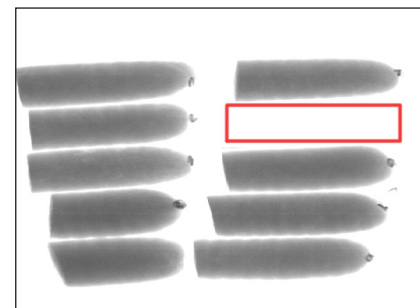

MULTI-LANE INSPECTION, which can check up to 8 lanes, provides complete flexibility in ejecting contaminated products.

REMOTE CONTROL and a 5-LEVEL PASSWORD PROTECTION SYSTEM mean many users can work, each with their own password. Production data and the machine's usage data have redundant storage systems to guarantee maximum safety. And thanks to the automatic creation of reports, the data is easy to understand

