



UV Sanitizer Portal

HTDS

OBJECTS DECONTAMINATION PORTAL
BASED ON A UV TECHNOLOGY, EFFECTIVE
AGAINST GERMS, BACTERIA AND VIRUSES

- 99.5% DECONTAMINATION OF OBJECTS & LUGGAGE IN 3 SEC
- AVAILABLE IN AUTONOMOUS MODE (STAND ALONE), OR SLAVE (SCANNERS & TRS)
- SIMPLIFIED AND FAST INSTALLATION ON ANY SCANNER BRAND (RETROFIT)
- FRENCH TECHNOLOGY AND MANUFACTURING

99.5% DECONTAMINATION

The UV Sanitizer Portal is designed around a certified Violeds technology. Tests conducted by the Korea University Research Group, first Korean university, reached a 99.9% sterilization of a surface contaminated with Coronavirus (COVID-19) in 30 seconds. The UV Sanitizer Portal uses the same technology with increased power by multiplying the number of LEDs, which allows a 99.5%* decontamination, faster on a moving object.

AVAILABLE IN SELF-CONTAINED OR SLAVE MODE

The UV Sanitizer Portal is available in stand-alone mode or optionally coupled with a scanner or a TRS (Tray Return System) regardless of its brand. In the latter case, the system is slaved to the scanner and its activation is triggered by the passage of luggage/object.

QUICK AND SIMPLIFIED INSTALLATION

Adding the UV Sanitizer Portal module to your existing scanners is done by replacing the exit cover and using an integration kit for quick implementation of your solution.

MULTIPLE APPLICATIONS

The UV Sanitizer Portal finds applications in many areas: airports, postal services, mass distribution, food industry, hospitals, events, hotels, sensitive sites ...



THE **UV SANITIZER PORTAL** IS USED FOR THE DECONTAMINATION OF OBJECTS THROUGH A FEW SECONDS EXPOSURE TO UV RADIATION. IT HELPS LIMIT THE PROLIFERATION OF GERMS, BACTERIA AND VIRUSES BY ELIMINATING 99.5% OF THE PATHOGENIC AGENTS PRESENT ON EXPOSED OBJECTS.

The UV Sanitizer Portal is integrated on a stainless steel cover to maximize the decontaminating effect of UV LEDs. Thanks to the reflective power of stainless steel, grey areas are eliminated and the entire volume under the exit hood is decontaminated.

FOR OPTIMAL DECONTAMINATION, DEPENDING ON THE SIZE OF THE UV TUNNEL, THE UV SANITIZER PORTAL USES FROM 6 TO 12 MODULES OF UV LEDS (ONE MODULE = 16 LEDS).



* Analysis report produced by the company STERIXEN to validate the quality of the decontamination at 99.5%.



UV Sanitizer Portal HTDS

SPECIFICATIONS

Operating temp.	<ul style="list-style-type: none"> • 0° C to + 40° C
Humidity	<ul style="list-style-type: none"> • 0 to 95%, without condensation
Power supply	<ul style="list-style-type: none"> • Power supply: 220V; 50Hz • Consumption: 24.8W (AC) per LED module • Integrated direct current transformation
Type of signage	<ul style="list-style-type: none"> • Operation light indication
Portal structure	<ul style="list-style-type: none"> • 304L stainless steel material panels • Treatment against aging, weathering and wear
Operational functions	<ul style="list-style-type: none"> • No heating time (Immediate start) • Conveyor speed: similar to that of the RX scanner in slave mode and 20cm / s in stand-alone mode
Command center (Stand-alone mode)	<ul style="list-style-type: none"> • Ergonomic and robust design • Made of industrial plastic or stainless steel and vandal-proof housing (Option) • Remote control
Quality	<ul style="list-style-type: none"> • Recognized reliability • No calibration required • No maintenance required • Fully digital design • No impact on the size of the machine (slave mode)

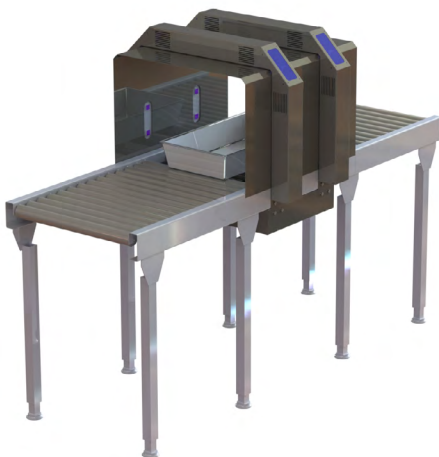

UV Sanitizer Portal in stand-alone mode



DIMENSIONS

In slave mode, the dimensions of the UV Sanitizer Portal adapt to the model of scanner on which it is installed.

Ex : Portal dimension for 620XR scanner type
Overall dimension: 805mm x 580mm x 93mm
Interior dimensions: 625mm x 500mm x 93mm

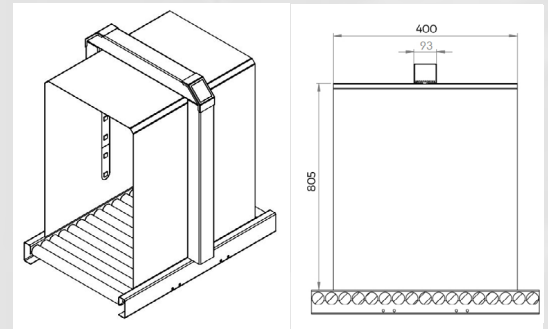

In stand-alone mode

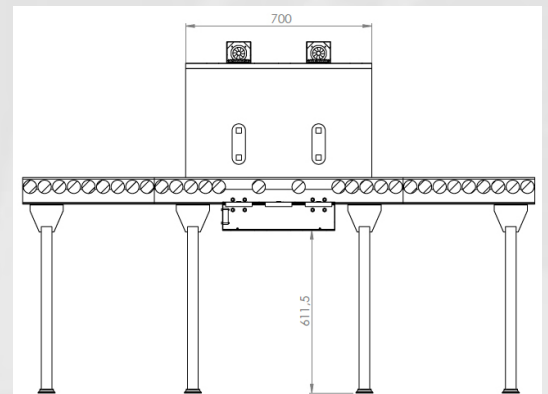

HTDS

Parc d'Activités du Moulin de Massy - 3 rue du Saule Trapu
BP246 - 91882 Massy Cedex France

Tel : +33 (0) 1 64 86 28 28 - Fax : +33 (0) 1 69 07 69 54 - info@htds.fr - www.htds.fr

HTDS Algeria : +213 232 384 01/02

HTDS Morocco : +212 222 749 59

HTDS Egypt : +202 229 053 06

HTDS Lybia : +218 91 69 50 70 8

HTDS Madagascar : +261 34 40 664 72

HTDS Tunisia : +216 70 836 961

