



EVOLV EXPRESS

Evolv Technology

FAST, EFFICIENT THREAT SCREENING

- SCREENS 3,600 PPL/HR, 10X FASTER THAN METAL DETECTORS
- NO STOPPING. NO EMPTYING POCKETS OR REMOVING BAGS
- SEE IN REAL-TIME WHERE THE POTENTIAL THREAT IS ON A PERSON'S BODY OR IN THEIR BAG
- FOR BOTH INDOOR AND OUTDOOR SCREENING. EASY TO SET UP AND MOVE
- MONITOR ENTRANT NUMBERS AND ALARM RATES

THE EVOLV EXPRESS

Evolv Express is the world's first and only touchless security screening solution that meets all of the post-pandemic security screening requirements. Express is proven to operate up to ten times faster than traditional metal detectors with its duallane, free-flow entrances and fusion of new sensor technology and artificial intelligence. The system is able to spot weapons while ignoring harmless personal items all while visitors simply walk through at a natural pace. Families and groups of people can now walk in together without long lines. It's a welcoming experience and allows them to make their way to the concessions or seats quicker.

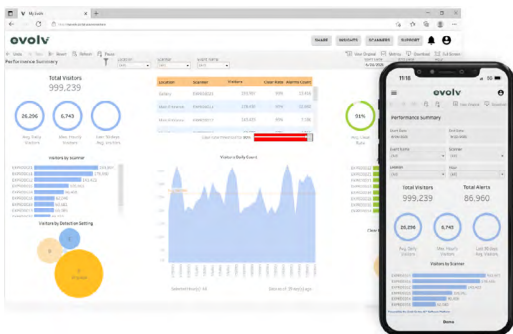

My Evolv Portal

Web-Based or Mobile Physical Security Management



THE EVOLV EXPRESS WEAPONS DETECTION SYSTEM COMBINES POWERFUL SENSOR TECHNOLOGY WITH PROVEN ARTIFICIAL INTELLIGENCE (AI), SECURITY ECOSYSTEM INTEGRATIONS, AND COMPREHENSIVE VENUE ANALYTICS TO ENSURE SAFER, MORE ACCURATE THREAT DETECTION AT AN UNPRECEDENTED SPEED AND VOLUME.

LEVERAGES AI TO INSTANTLY DIFFERENTIATE PERSONAL ITEMS FROM CONCEALED THREATS

Unlike traditional metal detectors, Express is powered by the combination of high-speed sensors and our proprietary AI software to identify threats in real-time without requiring visitors to stop, empty pockets, and remove bags. It can tell the difference between everyday items (cell phone, keys and coins) and a weapon. The system maintains dignity for visitors and employees while keeping the venues and facilities safe from unwanted threats such as mass shootings and terrorist attacks. It also reduces the risk of unnecessary human contact.

NOW, THE MAJORITY OF VISITORS WILL JUST WALK RIGHT THROUGH. NO ALARMS. NO NEED FOR SECONDARY SCREENING

When a potential threat is detected, real-time imageaided alarms show guards precisely where the potential threat is on a person or in his or her bag. Doing so greatly reduces the amount of physical contact required between guards/personnel, those being screened and their belonging, and allows guards to act swiftly and efficiently.



EVOLV EXPRESS

Evolv Technology



ENVIRONMENTAL SPECIFICATIONS

Operating Temperature	Min: -20C, Max: +55C
Storage Temperature	Min: -40C, Max: +70C
Relative Humidity	Up to 95%
Ingress Rating	Standard IP54 / Outdoor IP56**

PHYSICAL SPECIFICATIONS

Dimensions	• Depth: 40.3in (102.4cm)
	• Width: Dual Lane: 130.6in (331.7cm) Single Lane: 73.8in (187.5cm)
	• Height: 74in (188cm)
	• Weight: Dual Lane: 352 lbs (159.7kg) Single Lane: 281 lbs (127.5kg)
	• Mat lip: 0.184in (0.47cm) - Mat height: 0.89in (2.3cm)
Lane opening	• Width: Each 39.8in (101.1cm)
Power	• Voltage: 100VAC - 240VAC (+/-10%) • Phase: Single Phase
Consumption	• 200W max power consumption
Input/Output	• Line Cord - USB 2.0 (service access only) - Ethernet (RJ45) for Tablet

WIRED OR WIRELESS USER INTERFACE TABLETS

Tablet Options	<ul style="list-style-type: none"> • Choose from wired or wireless tablets • 2 per lane included, with 1 Floor and 1 Desktop Stand • Up to 3 tablets may be used per lane
Wired Tablet Specifications	<ul style="list-style-type: none"> • 15.6 inch Tablet (39.6 cm) • Outdoor 14 inch option ruggedized for weather protection and sunlight
Wireless Tablet Specifications	<ul style="list-style-type: none"> • Outdoor 14 inch Tablet ruggedized for weather protection and sunlight • Indoor 15.6 inch battery-powered tablet
Available Wireless Tablet Accessories	<ul style="list-style-type: none"> • Extra 90W Batteries • Battery Gang Charger (6 Battery Packs) • Single Bay Battery Charger with Adapter

OTHER SPECIFICATIONS

Health & Safety	<ul style="list-style-type: none"> • FCC CFR Part 15, CE Mark (CE Directives and Standards) • Global CB Scheme per CBTL Safety Standard • UL 61010, EN 61010 and IEC 61010 • U.S. Americans with Disabilities Act Compliant Access
Optional Accessories & Add-Ons	<ul style="list-style-type: none"> • Additional Wired or Wireless tabletwith floor or desktop stand • Thermal Imaging Package* • Custom Panel Graphics • Operational Test Kit
Analytics Portal	<ul style="list-style-type: none"> • View visitor analytics and alarm rate data by date, time, scanner, and location • Improve security staffing and venue resource planning by analyzing past metrics
Mobile Application	<ul style="list-style-type: none"> • Android- and iOS-compatible mobile application, with access to the portal and analytics

Standard Dual Lane System

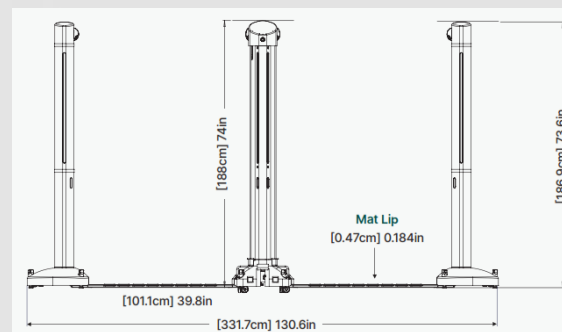

Standard Single Lane System

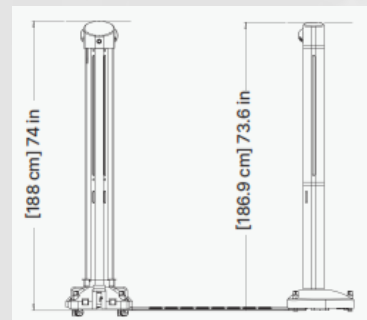

Standard Single Lane System : Top view

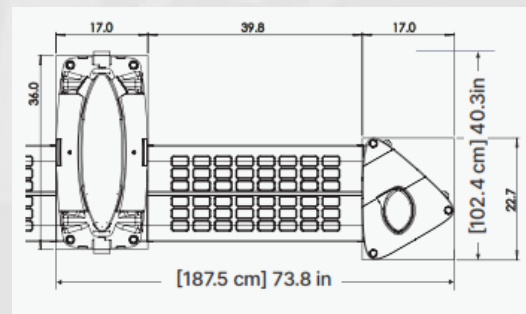

HTDS

Parc d'Activités du Moulin de Massy – 3 rue du Saule Trapu

BP246 - 91882 Massy Cedex France

Tél : +33 (0) 1 64 86 28 28 - Fax : +33 (0) 1 69 07 69 54 - info@htds.fr - www.htds.fr

HTDS West Africa : +225 07 78 78 69 32

HTDS Libya : +218 91 69 50 70 8

HTDS DRC : +243 990 086 063

HTDS Algeria : +213 232 384 01/02

HTDS Madagascar : +261 34 40 664 72

HTDS Tunisia : +216 70 836 961

HTDS Egypt : +202 229 053 06

HTDS Morocco : +212 222 749 59

